

IR in surveillance

Day-and-night cameras and OptimizedIR

June 2018



Summary

Light consists of discrete bundles of energy, called photons. The image sensor in a camera holds millions of photo-sensitive spots, pixels, that detect the number of incoming photons.

The ability of a camera sensor to detect photons is dependent of their energy, or their wavelength. Visible light photons, with wavelengths between 400 nm and 700 nm, are generally detected, but the sensor can usually also detect photons with slightly longer wavelengths (700-1000 nm), in the near-infrared part of the electromagnetic spectrum. Such light is naturally prevalent, for instance in sunlight, but can be added using artificial light sources as well.

Near-infrared illumination is commonly used in surveillance scenes that may otherwise be too dark. A so-called day-and-night camera can use both visible and near-infrared light, and deliver color video during the day and grayscale video during the night.

If natural IR light is completed with the addition of a designated IR light source, a day-and-night camera enables power-efficient and discreet surveillance even in complete darkness. The night-mode grayscale video has a low bitrate, which means that bandwidth and storage needs are minimized. The superior contrast and low noise levels also makes it particularly suitable for video analytics.

Standalone IR illuminators, to be used with day-and-night cameras, generally provide a longer reach than camera-integrated IR illumination, since they use a larger number of LEDs and give more light. But when IR LEDs are built-in with the camera, the complete, one-device installation is less environmentally intrusive and does not require any external cables or extra power supply.

Axis network cameras with OptimizedIR provide a unique and powerful combination of camera intelligence and sophisticated LED technology using Axis most advanced camera-integrated IR solutions. Examples include a patented technology for assuring an even illumination in the camera's variable field of view, extremely efficient heat management, and the use of long-range, high-quality LEDs that are fine tuned to the camera. OptimizedIR is in constant development, with new advanced features being added.



Table of contents

1. Introduction	4
2. Light sensitivity and the electromagnetic spectrum	4
3. IR imaging and IR illumination	5
3.1 Day-and-night cameras	5
3.2 Why use IR imaging instead of a thermal camera?	6
3.3 Why use IR illumination instead of visible-light illumination?	7
4. Camera-integrated or standalone IR illumination?	7
4.1 General IR illuminator requirements	8
4.2 Integrated illuminators	8
4.3 Standalone illuminators	8
5. Axis OptimizedIR	9
5.1 Flexible illumination angle	9
5.2 Adjustable light intensities	10
5.3 Power efficiency and durability	10
5.4 PTZ-camera customization	10
6. Safety in Axis IR equipment	10

1. Introduction

Most cameras can use both visible light and near-infrared (IR) light to produce images or video. By adding artificial IR illumination to a scene, it is possible to achieve high-quality video even in completely dark environments.

This document describes why IR illumination is widely used in surveillance. It discusses both camera-integrated and standalone illuminators, as well as the unique combination of IR solutions that is labelled Axis OptimizedIR.

2. Light sensitivity and the electromagnetic spectrum

Light consists of discrete bundles of energy, called photons. The image sensor in a camera holds millions of photo-sensitive spots, pixels, that detect the number of incoming photons. The camera uses this information to create an image.

Light also comes with different energy, or different wavelengths. The ability of a camera sensor to detect photons is dependent of their wavelength. Visible light photons, with wavelengths between 400 nm and 700 nm, are generally detected, but the sensor can usually also detect photons with slightly longer wavelengths (700-1000 nm), in the near-infrared part of the electromagnetic spectrum. Such light is naturally prevalent, for instance in sunlight, but can be added using artificial light sources as well.

Photons with even longer wavelengths, in the LWIR (long wave infrared) part of the spectrum, can be detected by a thermal camera sensor. LWIR light is heat radiation, naturally emitted by all living and non-living objects. In thermal camera images, warmer objects (such as people and animals) stand out from typically cooler backgrounds.

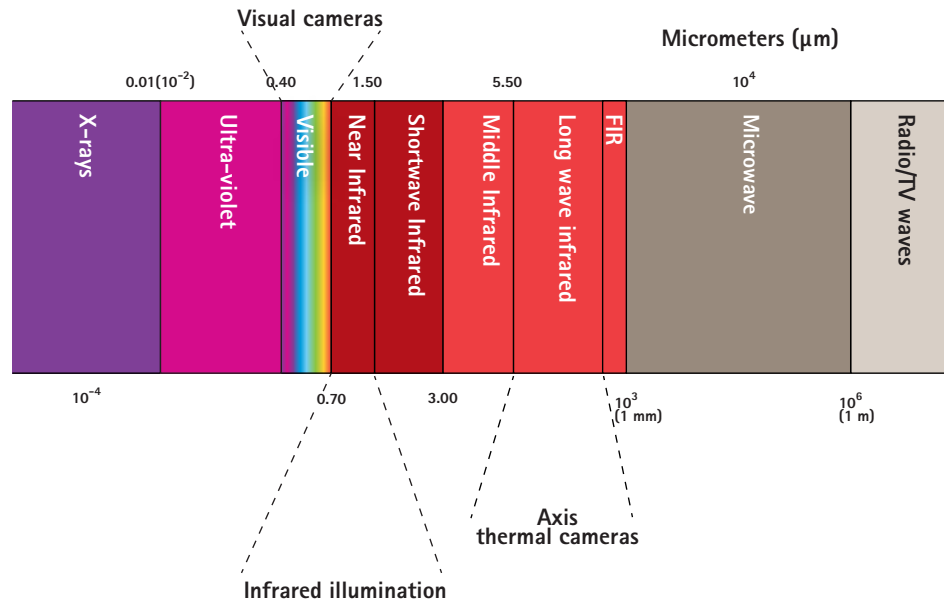

Figure 1: The electromagnetic spectrum, including the wavelength ranges of visual cameras and thermal cameras.

In low light, there are fewer photons available that can reach the camera sensor. Cameras with Axis Lightfinder technology have extreme light sensitivity, thanks to a balanced combination of sensor, lens and fine-tuned image processing, that enables the camera to create good color images using very few photons. However, when the scene is too dark, there are too few visible-light photons for the sensor to register. In such extreme low light scenes, the visible light (and color imaging) must be abandoned, and the spectrum must be broadened to include either near-IR wavelengths (using a day-and-night camera) or long-wave infrared wavelengths (using a thermal camera) in order to detect anything.

3. IR imaging and IR illumination

Using IR-LED illumination is a power-efficient and discreet way to enable surveillance in the dark. For imaging in complete darkness, IR light must be added using either standalone or camera-integrated IR illuminators.

Cameras that can use IR light for imaging have so called "day-and-night functionality", or are "day-and-night cameras". They can employ either natural IR light, such as moonlight, or artificial, from incandescent light bulbs or a dedicated IR light source. All cameras that have built-in IR illumination are day-and-night cameras, but a day-and-night camera does not necessarily have built-in illumination. Axis cameras with integrated IR illuminators are distinguished by the product name extension "-L" for LED, light-emitting diode.

Both camera-integrated and standalone illumination normally use IR light with a wavelength of 850 nm. IR LEDs are also available with 940 nm, but camera sensors are slightly less sensitive to that wavelength, as shown in the diagram of figure 2. Being so close to visible-light wavelengths, most IR LEDs produce a visible, faint red glow, which makes it possible to see whether the IR light is on or off.

Axis Lightfinder technology works with IR light as well as with visible light. A camera with Lightfinder enables the IR illumination to reach further, and makes natural IR light far away in the scene more visible.

3.1 Day-and-night cameras

Day-and-night cameras can switch between two modes: day mode and night mode. In day mode, the camera uses visible light and delivers color video. As light diminishes below a certain level of intensity, the camera automatically switches to night mode, where both visible and near-infrared light is picked up to deliver high-quality, grayscale video.

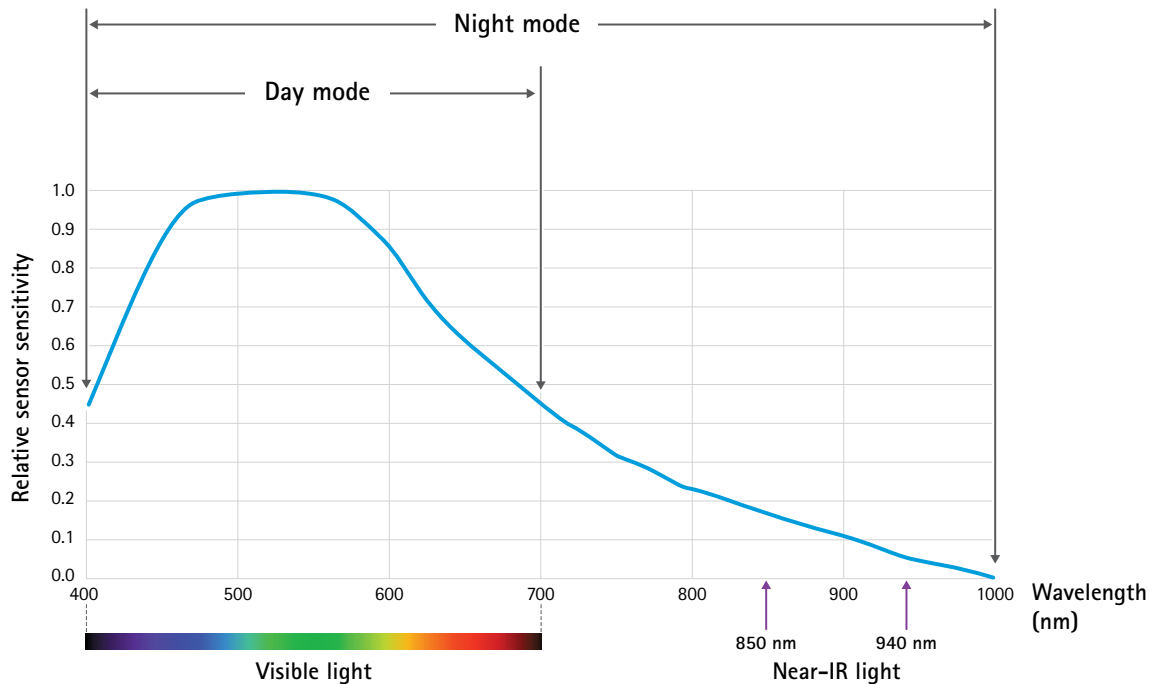

Figure 2: Diagram showing the relative light sensitivity of a visual camera sensor. When a day-and-night camera is in day mode, only visible light reaches the sensor. In night mode, both visible light and IR light in the lowest IR range reach the sensor and are used to produce video.

Switching between day mode and night mode is accomplished using a mechanically removable IR-cut filter. In day mode, the filter prevents any naturally occurring IR light from reaching the camera sensor, in order not to distort the colors of the video. In night mode, the filter is removed, increasing the camera's light sensitivity by allowing IR light to hit the sensor. Since the IR light leaks through all three color filter types (RGB) on the sensor, the color information is lost and the camera can no longer deliver a color image.

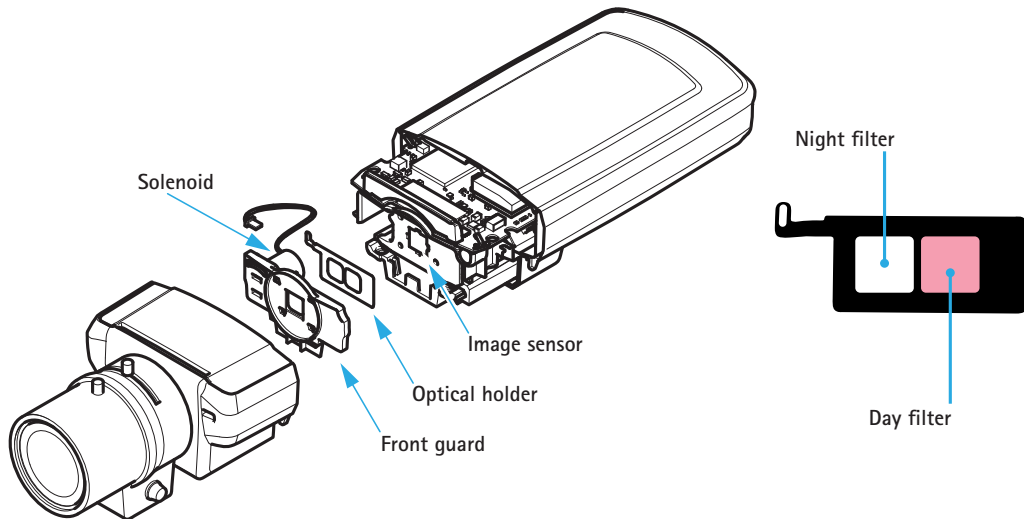

Figure 3: An IR-cut filter and its position in a day-and-night camera. In day mode, the red-hued filter is used to prevent any IR light from reaching the camera sensor

The grayscale video delivered during night mode accommodates the human eye's inability to see IR light. But materials with certain reflective properties may sometimes be represented in unexpected grayscale hues, for example, a dark jacket could appear to be of a much lighter nuance, and vice versa.

3.2 Why use IR imaging instead of a thermal camera?

Usable video in complete darkness can be provided by thermal cameras, as well as by visual cameras with IR illumination. Thermal cameras do not need any light source since they detect only heat radiation, naturally emitted by all objects.



Figure 4 and 5: To the left an image from a day-and-night camera with integrated IR illumination, and to the right an image from a thermal camera, passively detecting heat radiation.

The two camera technologies generally serve different purposes: thermal cameras mainly detect presence, while IR cameras can, depending on the conditions, be used to recognize or identify individuals. Cameras with built-in IR can thereby be used for complete, standalone surveillance, but can also be integrated into a larger, diversified, surveillance system. Thermal cameras, on the other hand, can very well complement a surveillance system, but not replace it; visual cameras are generally needed somewhere in the system for identification.

Thermal cameras have an impressive range of detection, counting in kilometers, but they are expensive to buy. The range of a visual camera with IR illumination depends on the resolution of the camera and how far the illumination reaches. For Axis IR products, the datasheets provide information about the illumination reach, as assessed outdoors at night, for real objects in real scenes.

Thermal cameras cannot see through glass, but visual cameras using IR illumination can. The effects of this aspect depend on the circumstances and the surveillance purposes. For example, using a thermal camera could be beneficial in indoor surveillance since it would prevent accidental filming out the windows, where surveillance may not be permitted.

For more information about thermal camera technology, see:
www.axis.com/technologies/thermal-imaging.

3.3 Why use IR illumination instead of visible-light illumination?

In locations where artificial white light illumination is restricted, or where it would be too intrusive, IR illumination provides a way to make surveillance possible.

One example is in nighttime traffic surveillance, where white light could be too disturbing for the drivers. IR also benefits from enabling very discreet surveillance, strategically useful in many scenarios, apart from not adding to general light pollution. The deterrent effect of visible light illuminators is, however, often preferred.

IR illumination can be used when it is not critical to capture color information. But grayscale video also has a significantly lower bitrate than color video, which means that bandwidth and storage needs are minimized.

The superior contrast and low noise levels delivered by a day-and-night camera with IR illumination also makes it particularly suitable both for video analytics and for night-time surveillance of high-speed objects, such as, again, traffic surveillance. License plate recognition (LPR) is a video analytics application that, in some cases, benefits from IR-illuminated video. License plates reflect much more IR light than any other objects in the image, enabling the LPR algorithm to react on license plates and nothing else. Any unauthorized modifications to license plates are also easily detected.

4. Camera-integrated or standalone IR illumination?

Artificial IR illumination can be supplied by standalone IR illuminators or be integrated into the camera. Surveillance applications may benefit from using both types simultaneously, since standalone illuminators are generally more powerful and reach further, but camera-integrated illuminators may be more suitable at shorter range, due to them being uniquely adapted and tailored to the specific camera with its features, zoom levels, and so on.

4.1 General IR illuminator requirements

An IR illuminator, whether camera-integrated or standalone, should provide a uniform light field within the camera's whole field of view. It should have a long reach, but also avoid causing the camera to overexpose objects that are close by. This generally requires a camera with wide dynamic range.

IR illuminators should have integrated visual light detectors and automatically shut down, for power saving, during day or when other light sources provide enough light. Overheating of the LEDs must also be avoided, to enable a long LED lifetime.

4.2 Integrated illuminators



Figure 6: A network camera from Axis with three integrated IR LEDs

With camera and illumination in one device, the complete installation is less environmentally intrusive. This is especially important for surveillance in older or listed buildings, such as museums and historical buildings.

Axis network cameras with built-in IR are easy to install and integrate. They do not require any external cables or extra power supply since their low-power IR LEDs are powered from the camera, using Power over Ethernet (PoE). A system with camera-integrated illumination can also be less expensive, with fewer components to install, and, consequently, fewer components to perform service and other maintenance on.

4.3 Standalone illuminators



Figure 7: A standalone IR LED illuminator from Axis, to be used with a day-and-night camera.

Standalone IR illuminators, to be used with day-and-night cameras, generally provide a longer reach than camera-integrated IR illumination, since they use a larger number of LEDs and give more light. They also allow the camera to be aimed more freely.

Since light and camera lens are more physically separated when standalone illuminators are used, compared to camera-integrated IR, insects and dirt which are naturally drawn to the light do not get so close to the lens that they can affect the video.

When using standalone illuminators, it should be ensured that the illumination matches the scene. A too narrowly illuminated area will cause white out or glare in the middle of the scene and inadequate illumination at wider angles. On the other hand, a too widely illuminated area entails both a reduced light reach in the forward direction, and the unnecessary illumination of objects that are outside the area of interest.

Standalone illuminators from Axis come with exchangeable, diverging lenses, to enable an illumination width that suits the scene. Since any adjustments of the illuminators must be done manually on site, standalone illuminators are best used with cameras that keep a rather constant zoom level and field of view.

5. Axis OptimizedIR

Axis network cameras with OptimizedIR provide a unique and powerful combination of camera intelligence and sophisticated LED technology using Axis most advanced camera-integrated IR solutions. Examples include a patented technology for assuring an even illumination in the camera's variable field of view, extremely efficient heat management, and the use of long-range, high-quality LEDs that are fine tuned to the camera. OptimizedIR is tailored in each camera model, and may consist of different solutions depending on the camera's specific prerequisites and functionalities. OptimizedIR is also in constant development, with new advanced features being added.

5.1 Flexible illumination angle

One feature of OptimizedIR, used in selected, remote-zoom cameras, is that the angle of illumination can adapt to the zoom level. Using high-precision, custom-made lenses, the IR LEDs provide an illumination angle that follows the camera's zoom movements to always provide the right amount of light. The entire field of view is evenly illuminated, resulting in well-exposed, high-quality, low-noise video, even when the environment is completely dark.

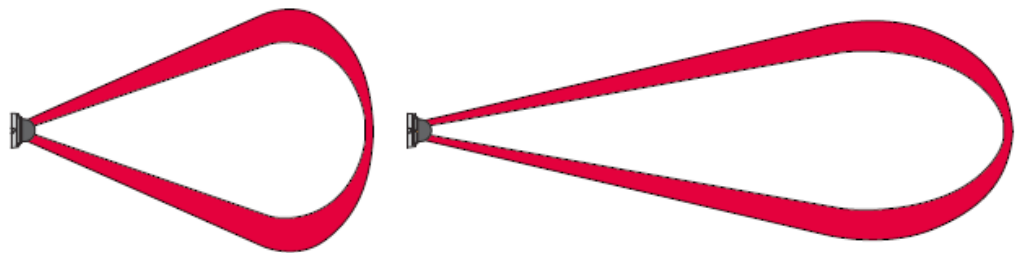

Figure 8: In some cameras, OptimizedIR can be used to control the IR illumination angle, so that it follows any adjustments made in the camera zoom level and field of view.

5.2 Adjustable light intensities

In some of Axis most advanced solutions, the intensity of the camera-integrated LEDs can be manually or automatically adjusted. If needed for optimal image quality, individual lights can be either dimmed or turned off, remotely via the web interface.

The camera automatically adjusts the exposure for optimal image quality. When installed close to a wall or a corner, it can also be beneficial for the camera to automatically dim the LEDs located closest to that wall or corner, in order to avoid reflections that could otherwise saturate parts of the image.

Depending on the installation environment and the conditions around the camera, for example, external light sources in the scene, manual intensity adjustments of individual LEDs may also be useful for customizing the IR illumination.

5.3 Power efficiency and durability

OptimizedIR is based on extremely power-efficient LEDs. Due to the minimal heat dissipation, PoE is enough to power them, and no additional power cables are needed.

The LEDs are high-quality and durable, and their lifetime is further prolonged because of their low heat generation. With a lower operating temperature, the LEDs last longer. OptimizedIR is a power-efficient technology also because it illuminates the scene evenly and minimizes the amount of light outside the view. This is achieved by using few LEDs, with an optimized mechanical design.

5.4 PTZ-camera customization

Thanks to advanced heat management solutions and sophisticated camera features, Axis offers OptimizedIR also in selected pan-tilt-zoom (PTZ) cameras. Using several LEDs with different lenses and variable light intensities, the resulting illumination is optimally adjusted for the field of view and zoom factor. Whether the camera is panning, tilting, or zooming, the IR light beam adapts seamlessly to the camera view.

For a discreet design of a PTZ camera, any integrated LEDs must be located close to the image sensor, without being connected to any external heatsink. This makes cooling of the LEDs critical.

Axis PTZ cameras with OptimizedIR use heatpipes for conducting LED-generated heat away from both the sensor and the LEDs, allowing those to maintain a suitable operating temperature. This enables the sensor to produce high-quality, low-noise images, and ensures a long LED lifetime. The heat management solution also enables a compact and directionally discreet dome design, which, together with the near-infrared lighting of OptimizedIR, provides fully discreet surveillance.



Figure 9: A PTZ camera with OptimizedIR.

6. Safety in Axis IR equipment

Axis network cameras are safe to use according to the European standard EN 62471:2008, based on the international standard IEC 62471. Complying with this standard, the cameras and their built-in illumination are not harmful to the eyes of any living creature looking straight at the camera.

About Axis Communications

Axis offers intelligent security solutions that enable a smarter, safer world. As the global market leader in network video, Axis is driving the industry by continually launching innovative network products based on an open platform – delivering high value to its customers and carried through a global partner network. Axis has long-term relationships with partners and provides them with knowledge and ground-breaking network products in existing and new markets.

Axis has more than 2,700 dedicated employees in more than 40 countries around the world, supported by a network of over 90,000 partners across 179 countries. Founded in 1984, Axis is a Sweden-based company listed on NASDAQ OMX Stockholm under the ticker AXIS.

For more information about Axis, please visit our website www.axis.com.