

## **AXIS P32-VE/-LVE Series**

## **Repainting Instructions**

# AXIS P32-VE/-LVE Series

## Impact on warranty

---

### Impact on warranty

This product is approved for repaint by Axis, provided that you follow the instructions in this document and at [www.axis.com/warranty-implication-when-repainting](http://www.axis.com/warranty-implication-when-repainting)

### Risks with repainting

There are several risks when disassembling or assembling an Axis product. There is always a certain yield loss during assembly. Training of operators and the use of correct tools mediates some of the problems but they can never be fully avoided. Some of the risks are listed below:

**ESD Damage** – Always handle the product in an ESD safe environment. Even if precautions are taken there is always a risk of ESD damage. The damage can remain undetected and cause problems during the lifetime of the equipment.

**Dust contamination** – Opening a camera may expose the lens and sensor to dust or paint; dust will affect the optical performance. Lenses need to be disassembled in a dust-free environment, preferably a cleanroom.

**Paint overspray** – Masking of the different components of the equipment is critical. Failure to mask sensitive areas could cause problems with assembling the equipment. Any areas that are not painted from factory or have a different surface treatment than the rest of the part (threads, ground and electrical contact surfaces) must also be masked to ensure function.

# AXIS P32-VE/-LVE Series

## How to repaint the product

---

### How to repaint the product

#### Disassembly

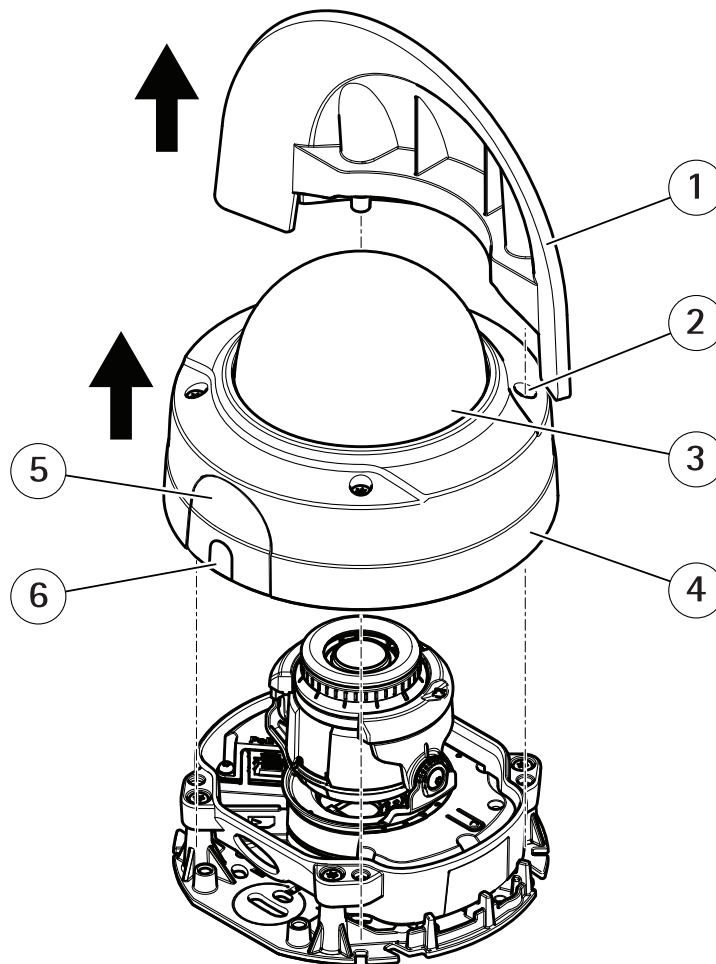

- 1 Weathershield
- 2 Screws (4x, TR20)
- 3 Dome
- 4 Dome cover
- 5 Conduit cover
- 6 Cable cover

1. Remove the weathershield.
2. Remove the dome cover.
3. Remove the cable cover or conduit cover if you are not going to use it.

# AXIS P32-VE/-LVE Series

## How to repaint the product

---

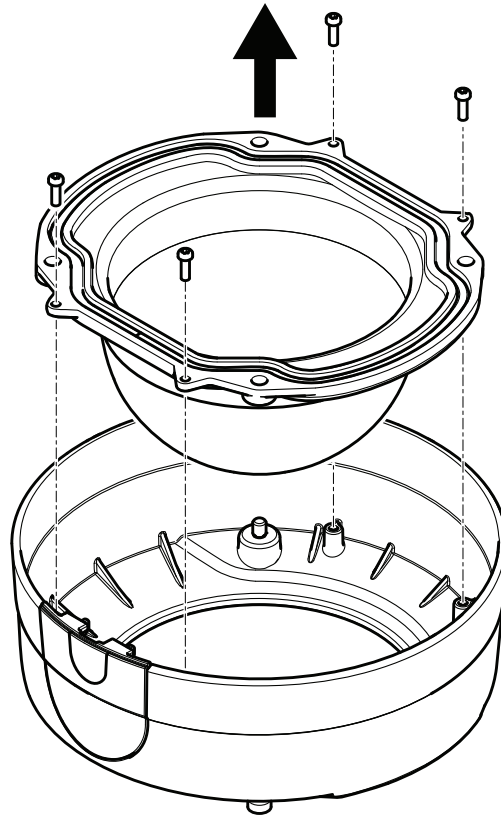

4. Remove the dome from the dome cover (4 screws, T8).

### Preparations

- The equipment must be disassembled according to instructions *How to repaint the product on page 3*.
- Each part is then stripped from components and crucial parts are masked to ensure successful reassembly.
- All parts to be repainted should be stripped of gaskets, screws, electrical components, connectors and plugs, windows and domes.
- All parts to be repainted must be thoroughly cleaned to remove grease, dust or oil.
- To ensure reassembly and functionality of the product, openings for screws, LED indicators, or microphones must be masked before painting.

### Pretreatment of parts

Depending on the part material and type of paint applied from factory, different pretreatments should be done for the new paint to adhere as well as possible. For all variants though, proper cleaning to remove oil, grease and dust is strongly recommended.

For information about which materials are used in the product, see the datasheet available at [www.axis.com](http://www.axis.com)

**Powder coated parts** – Using fine sandpaper, remove the original powder coating down to the stainless steel surface and clean the parts before painting, or use primer.

**Anodised and chromated parts** – Primer is required.

**Uncoated stainless steel** – No special pretreatment is needed. Just make sure the surface is clean before painting.

# AXIS P32-VE/-LVE Series

## How to repaint the product

---

Plastic - Primer is required.

### Repainting

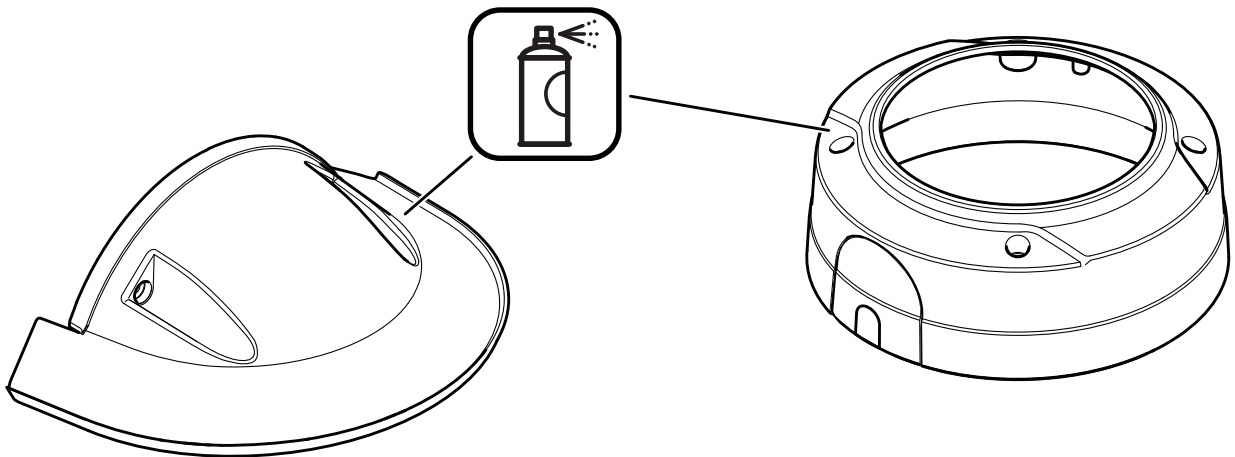

1. Make sure all necessary preparations of the weathershield and dome cover have been made, see *Preparations on page 4*.
2. Apply a thin and even layer of spray paint according to the instructions of the paint manufacturer.
3. Let the paint dry.
4. To get a better coverage and clearer color, apply a second layer of spray paint.
5. When the paint is dry, remove the masking and reassemble the product.

### Reassembly

1. Reattach the dome to the dome cover and tighten the screws (torque 0.35 Nm, 0.26 lb ft).
2. Reassemble the weathershield, dome cover and camera and tighten the screws (torque 1.0 Nm, 0.7 lb ft).

