



SAMCON
Prozessleittechnik GmbH



Assembly Instruction

product: WMB EXCAM XF
author: S. Weber
date: June 25, 2018
doc ID: 180625-PZUMA-SW-WMB EXCAM XF_assembly
instruction_rev.02.idw
passing:



INTRO



What you need:	
Allenwrench	6mm
Wrench	17mm
Tourque -wrench / -allenwrench	6mm - 17mm

ATTENTION:

Please be careful when working at heights !

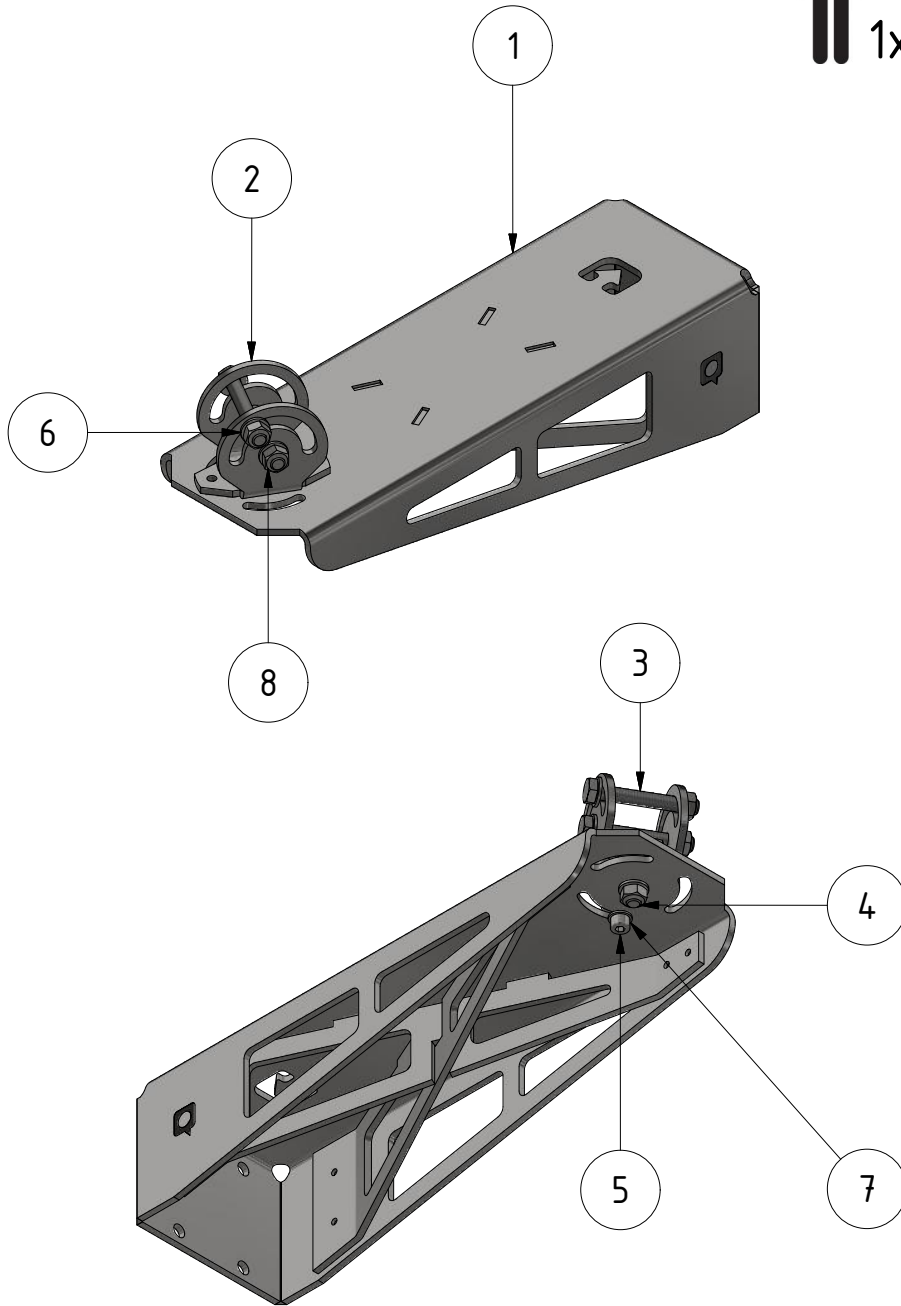
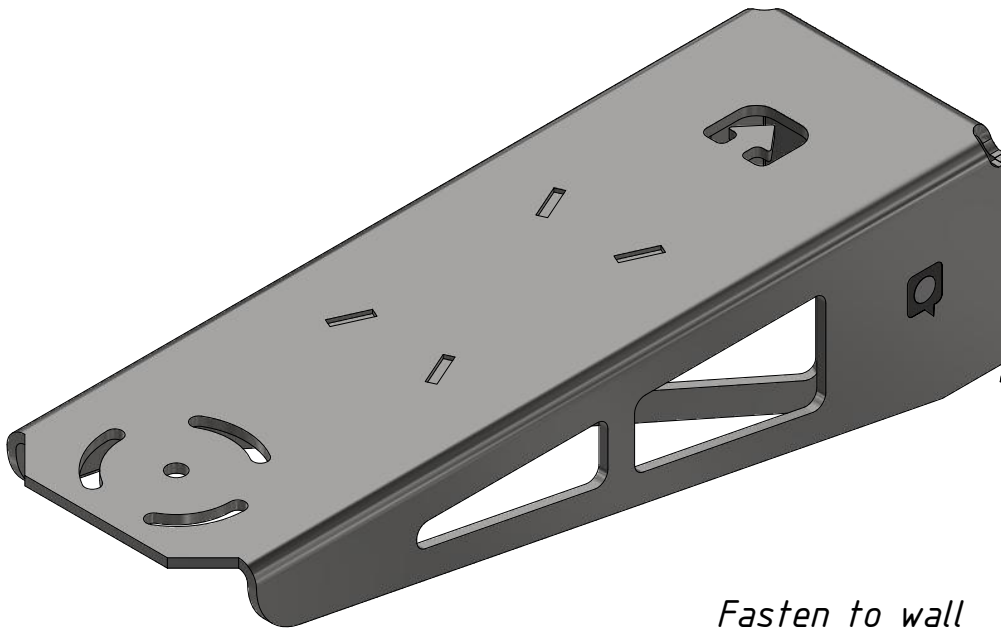

Table of content

obj.	qty.	part	material
1	1	WMB EXCAM XF	stainless steel
2	1	WMB EXCAM XF fastening sheet	stainless steel
3	2	Threaded bolt ISO 4017 - M10 x 70	stainless steel
4	1	Threaded bolt ISO 4017 - M10 x 25	stainless steel
5	1	Threaded bolt DIN 912 - M8 x 16	stainless steel
6	6	Washer DIN 125 - A 10,5	stainless steel
7	1	Washer DIN 125 - A 8,4	stainless steel
8	3	Nut ISO 4032 - M10	stainless steel

1



*Fasten to wall
or to PMB first !*

2

tightening: 15Nm

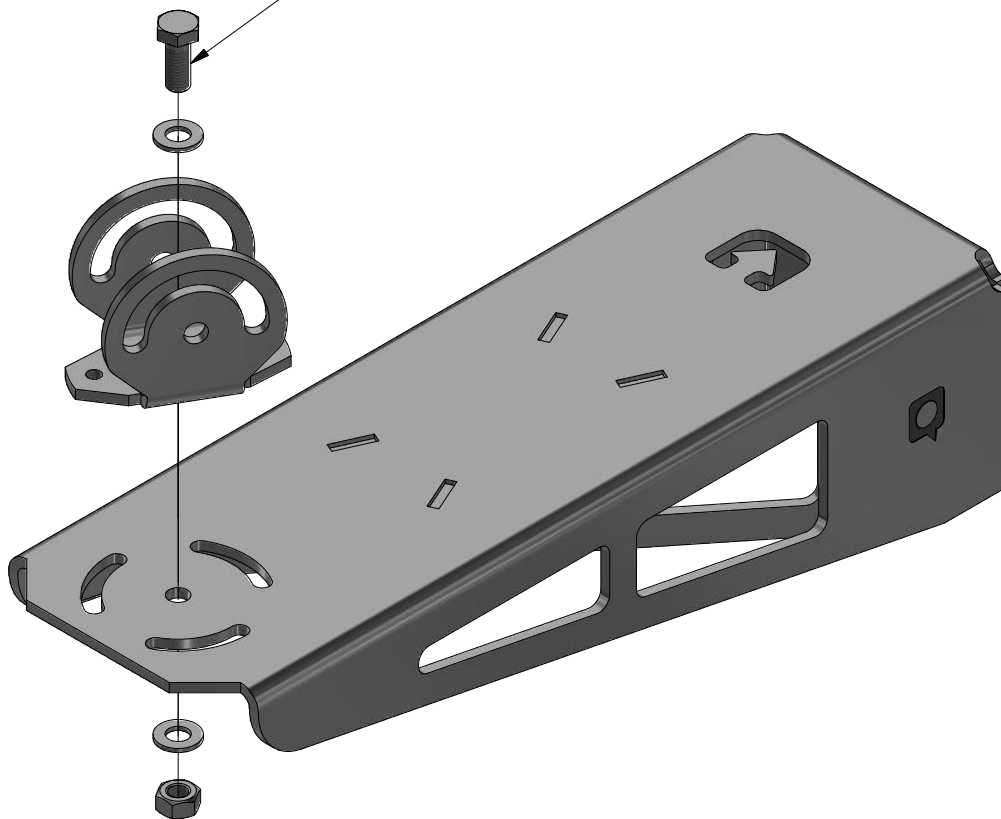

3

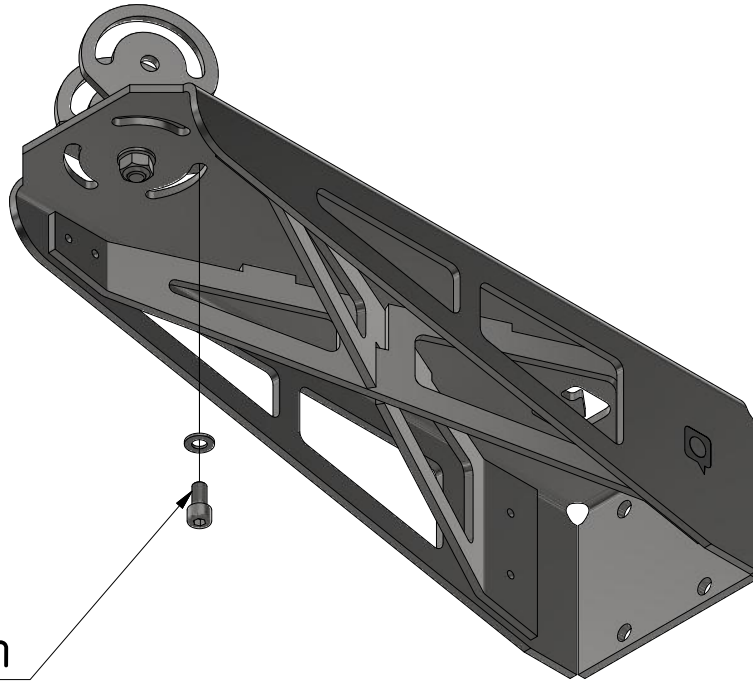

tightening: 10Nm

4

Fasten safety wire first!

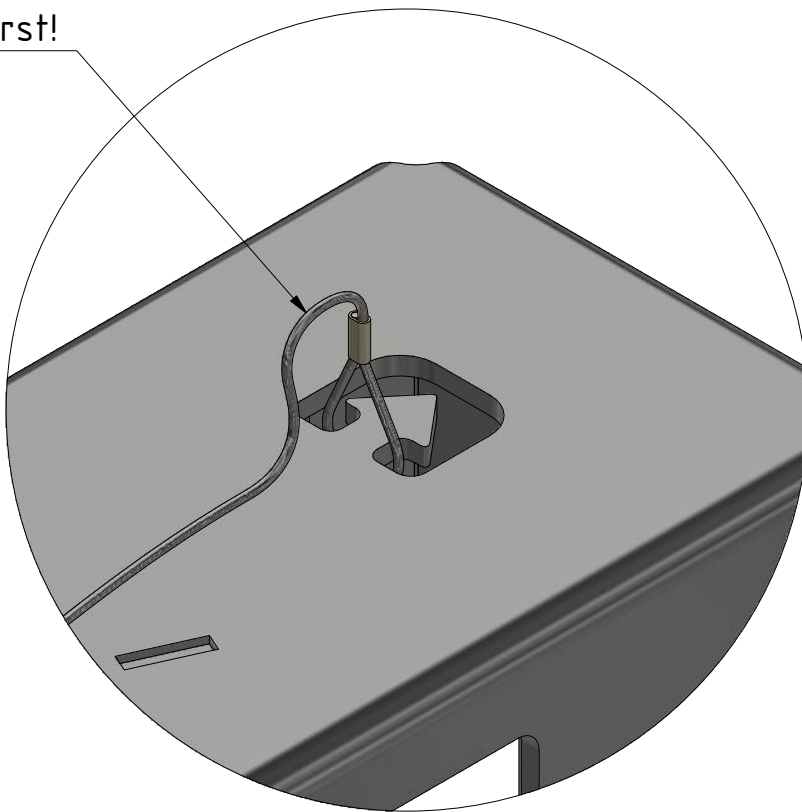

5

tightening: 15Nm

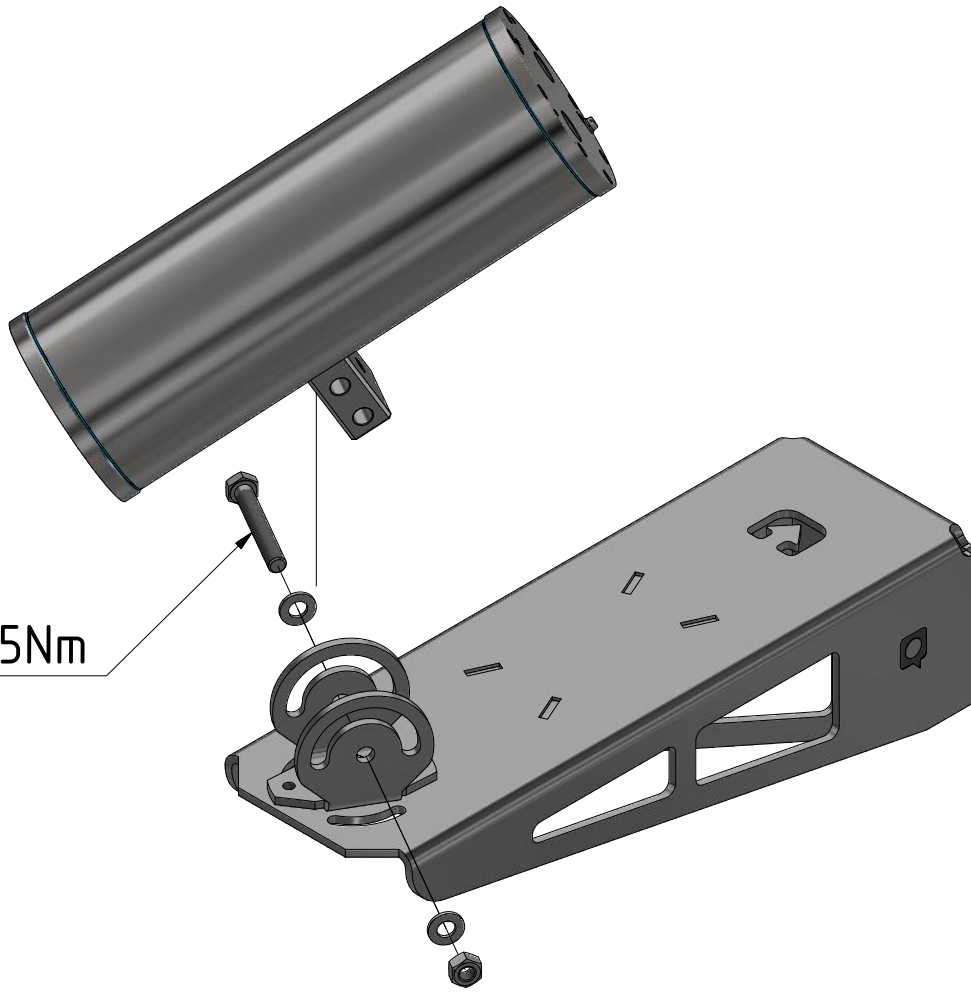

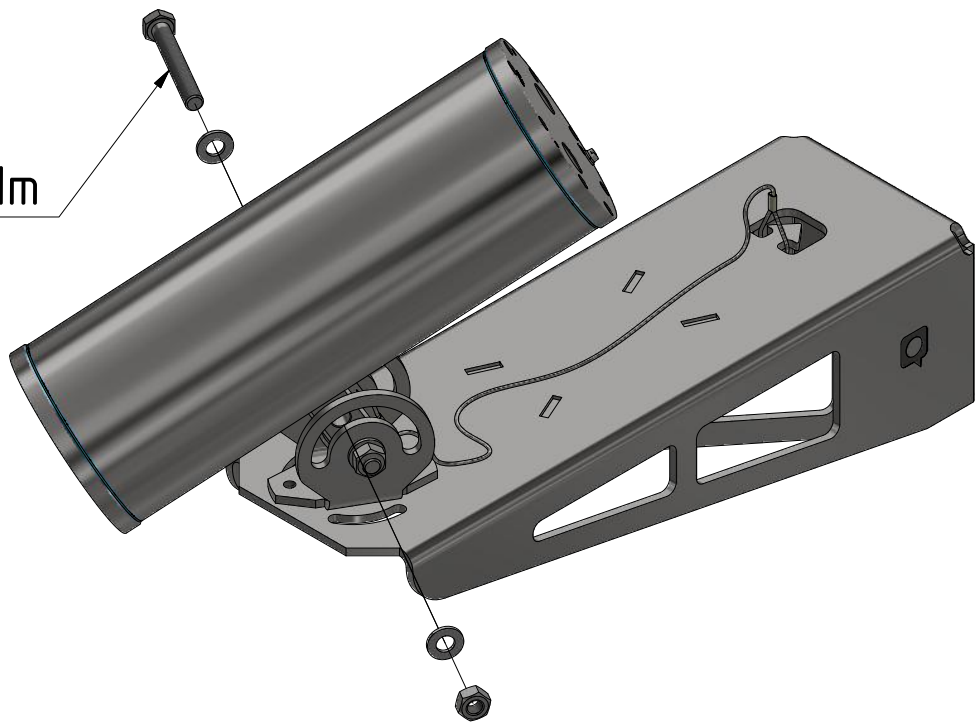

6

tightening: 15Nm

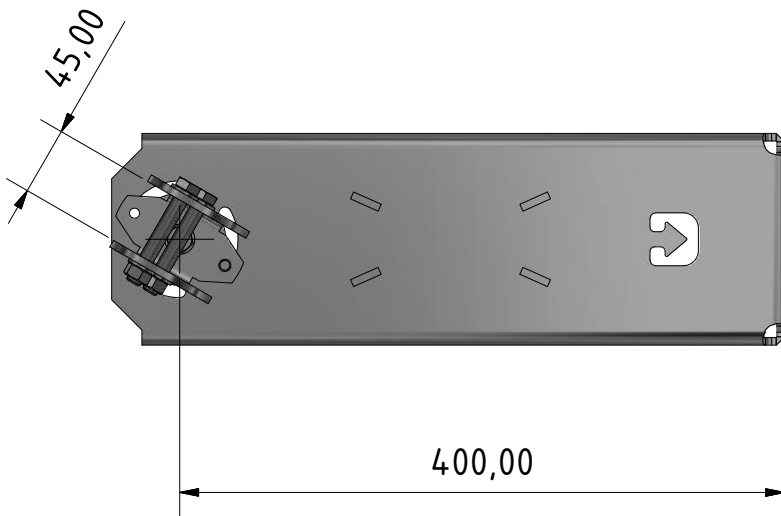
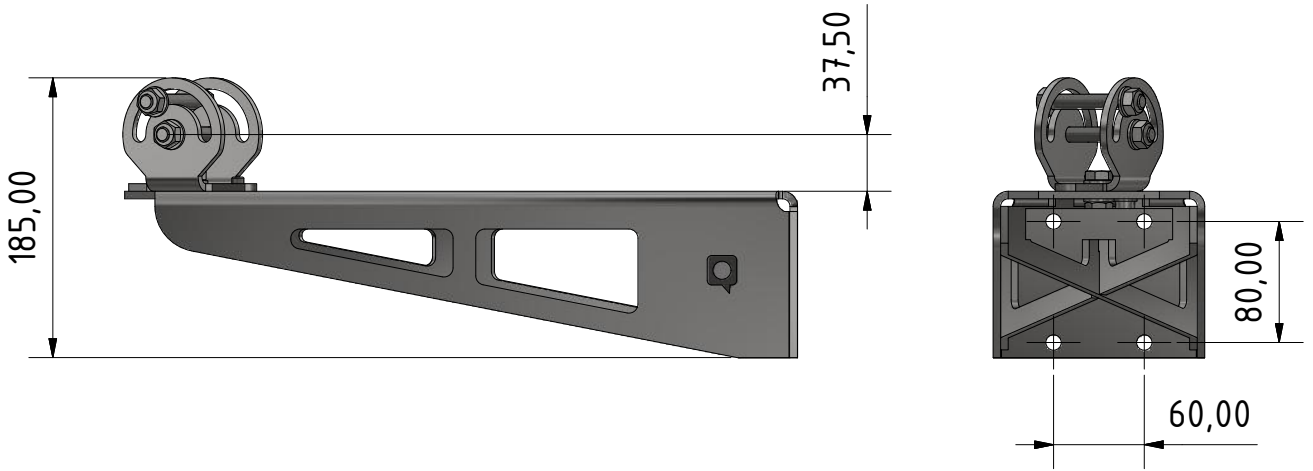
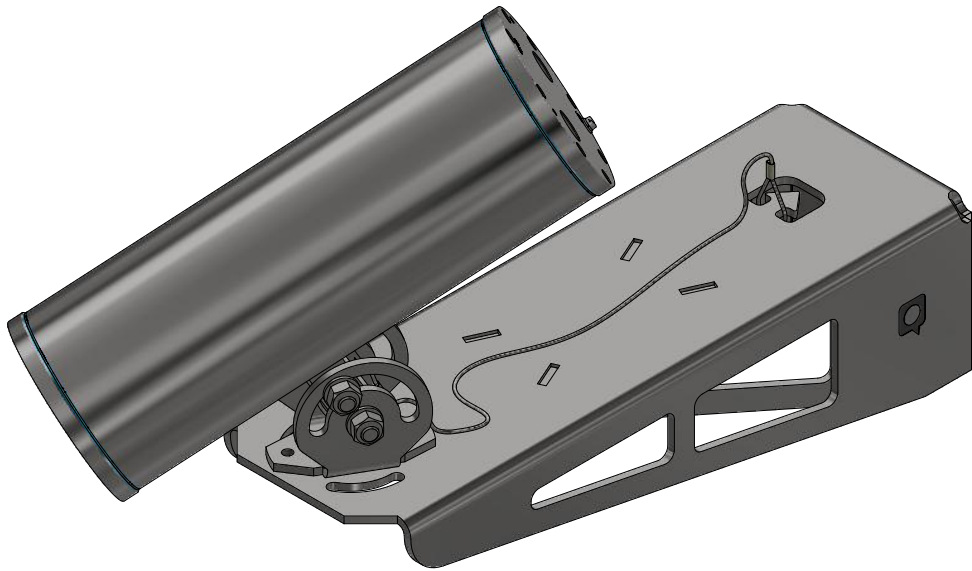

7





Note:
For more information see
other assembly instructions!



SAMCON

Prozessleittechnik GmbH

AXIS[®] 
COMMUNICATIONS