

Cable Kit ASKDP03-T 95 M

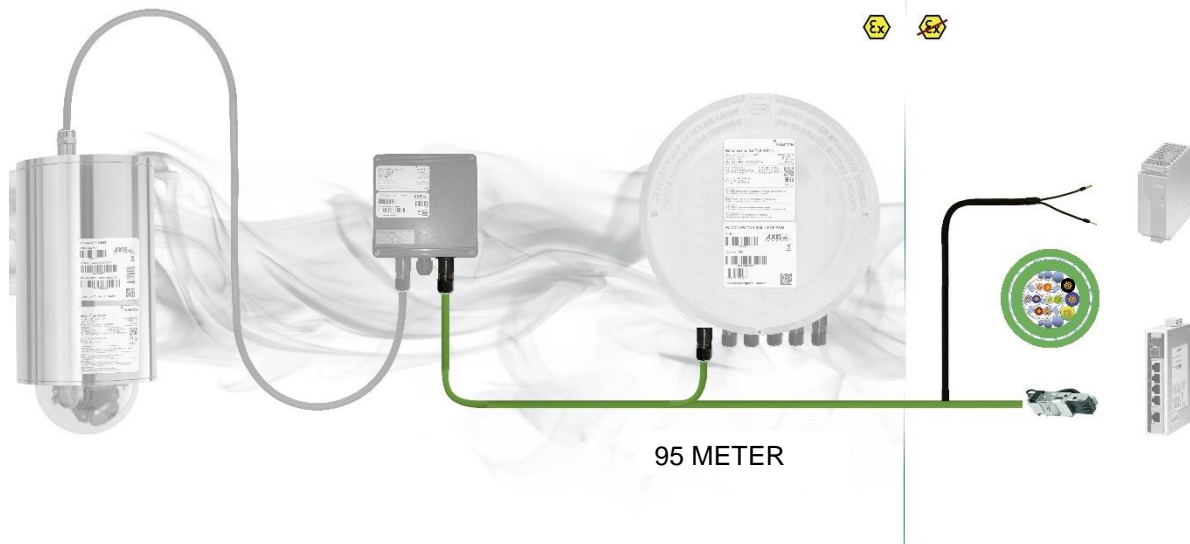

Mounting instructions

Contents

1	Content of the Cable Kit.....	3
2	Installing and wiring (Customization of the cable connection).....	3
2.1	The wire construction	4
2.2	Preparation of the cables	4
3	Insertion into Ex e	6
3.1	Components of the cable gland Ex e.....	6
3.2	Installation of the cable gland Ex e for armoured cables	6
3.3	Connecting the cable to the clamps	7
4	Insertion into Ex d	8
4.1	Components of the cable gland Ex d.....	8
4.2	Installation of the cable gland Ex d for armoured cables	8
5	Connecting the RJ 45 plug (Ex d or non-ex)	9
6	Connecting the power channel (24VDC)	10
7	Support / contact.....	10
8	Notes	11

Table of Figures

Figure 1.1	– Content of the Cable Kit ASKDP03-T	3
Figure 2.1	– Cable cross section	4
Figure 2.2	– Stripped cable and bare shielding	4
Figure 2.3	– Blank shielding wire and shielding braid.....	5
Figure 2.4	– Shrinking tube over twisted shielding braid	5
Figure 2.5	– Customized cable	5
Figure 3.1	– Components of the CMP cable gland	6
Figure 3.2	– Installation of the cable gland 1	6
Figure 3.3	– Installation of the cable gland 2	7
Figure 3.2	– Connection in the terminal box	7
Figure 4.1	– Components of the Capri cable gland	8
Figure 5.1	– Connecting the RJ 45 plug	9
Figure 5.2	– Completed cable with a RJ 45 plug	9

Revisionhistory

Product: Cable Kit ASKDP03-T 95 M
 Title: Cable Kit ASKDP03-T 95 M Mounting instructions
 Doc. -Id. CableKitASKDP03-T_95M_MountingInstructions_rev.00.docx
 Author: Eva Schneider
 Date: 27 June 2019

Rev.- Index	Date	Name	Comment	Approved by EX Officer
0	27. June 2019	E. Schneider	Compilation of the documents	

1 Content of the Cable Kit

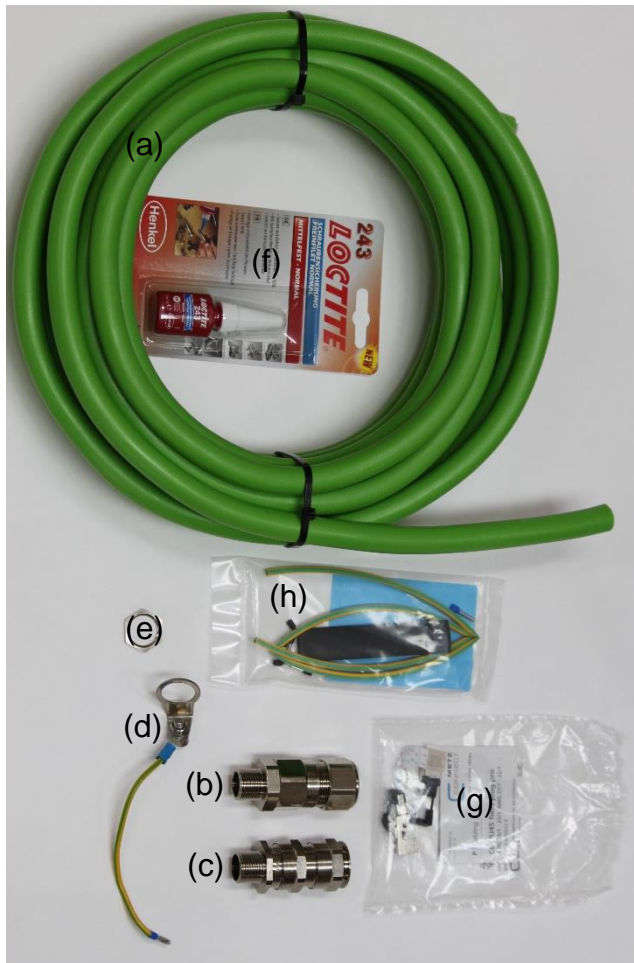

Figure 1.1 – Content of the Cable Kit ASKDP03-T

- ✓ 95 m ASKDP03-T Armoured System Cable Digital (a)
- ✓ 1 x cable gland Ex e for amoured cables (CMP) for insertion into the junction box ExTB-3 (b)
- ✓ 1 x cable gland Ex d/e for armoured cables (Capri) for insertion into the ExConnection Rail (c)
- ✓ 1 x grounding ring (d)
- ✓ 1 x sealing ring (e)
- ✓ 5 ml Loctite threadlock (f)
- ✓ 1 x CAT6 RJ45 industrial plug pro (5.5 – 10.5 mm) (g)
- ✓ 60 cm shrinking tube yellow-green (h)
- ✓ 10 cm shrinking tube black (h)
- ✓ 8 x wire-end ferrules (h)
- ✓ 1 x documentation

2 Installing and wiring (Customization of the cable connection)

In the following chapter it is described how to customize the cable to connect it. For connection with the junction box ExTB-3 remove 20 cm of the insulation. For connection with the ExConnection Rail remove 30 cm of the insulation.



Attention!

The electrical connection of the equipment must be executed by qualified personnel only!



Attention!

Please observe the national regulations regarding security, installation, and accident prevention (e.g. IEC 60079-14)!



Attention!

When stripping the insulation, no inner cores must be damaged!

2.1 The wire construction

Looking at the digital system cable's cross section, the following elements are visible:

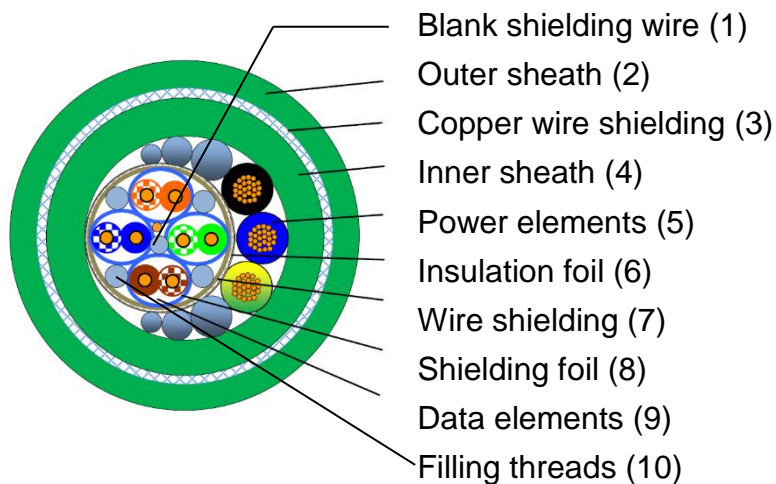

Figure 2.1 – Cable cross section

2.2 Preparation of the cables

If you would like to connect the cable ASKDP03-T to the junction box ExTB-3, remove 20 cm of the outer sheath (2) and 18.8 cm of the copper wire shielding (3). Then strip the inner jacket (4) off over a length of 17 cm.

If you would like to connect ASKDP03-T to the ExConnection Rail, remove 30 cm of the outer sheath (2) and 28.5 cm of the copper wire shielding (3). Then strip the inner jacket (4) off over a length of 27 cm.

Make sure that the wires are not damaged. In a next step cut off the white filling threads and remove the white foil around the network wires (6) so that the shield is uncovered. After that separate the shield by pulling out the data elements (9) from the wire shielding (7) (see figure 2.2).



Figure 2.2 – Stripped cable and bare shielding

Cut off the five filling threads (10) and the plastic foil. Make sure that the blank shielding wire (1) is not removed. Twist this blank wire with the shielding (7) as shown on the following page:



Figure 2.3 – Blank shielding wire and shielding braid

Cut the yellow-green shrinking tube to match the length of the shielding braid. Now shrink-fit the shrinking tube by using a hot air blower.



Figure 2.4 – Shrinking tube over twisted shielding braid

After this, put the black shrinking tube over all cables and the shielding and shrink it. Remove approx. 1 cm of the foil (8) at the top of the 4 twisted pairs. Untwist them to match this length and cut off the ends with a wire stripper. Squeeze the wire end ferrules onto the 3 power elements and the grounding wire.

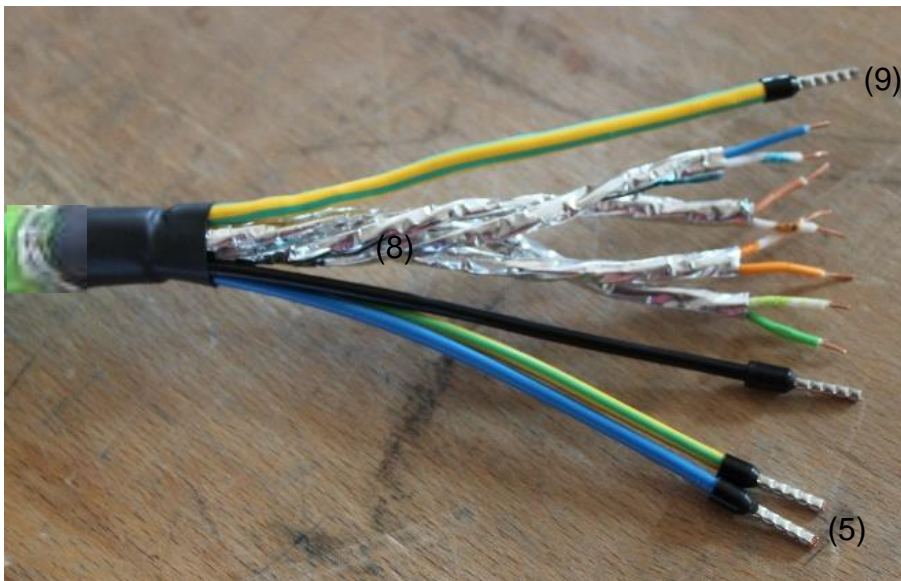

Figure 2.5 – Customized cable

3 Insertion into Ex e

In this chapter the connection to the junction box ExTB-3 is described.

3.1 Components of the cable gland Ex e

The used cable gland for armoured cables for insertion into Ex e (further referred to as CMP cable gland) is shown on Fig. 1.1 (b).

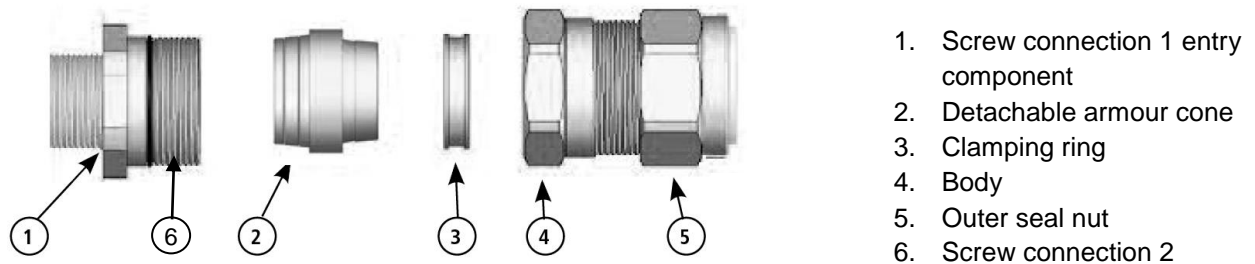

Figure 3.1 – Components of the CMP cable gland

3.2 Installation of the cable gland Ex e for armoured cables

Remove the ExTB-3 terminal box' right cable gland and insert the CMP cable gland with the sealing ring on its top. Push the grounding ring from the inner side of the junction box. Fix the CMP cable gland with the counter nut of the original cable gland.

Slacken the Outer Seal Assembly (5), but do not remove it from the Body (4). Separate the gland components by removing the Body (4) and the Outer Seal Assembly (5) as one unit (note that the Reversible Armour Cone (2) and the Clamping Ring (3) are loose items). Pass the Body (4), Outer Seal Assembly (5) and Clamping Ring (3) over the cable, Outer Seal Assembly (5) first. Insert the prepared cable (see chapter 2).

Locate the Reversible Armour Cone (2) in the Entry Component (1), grooved side outwards. Pass the cable through the Cone (2) and Entry Component (1), evenly spacing the braid or armour around the Cone (2).

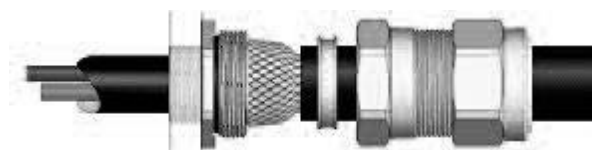

Figure 3.2 – Installation of the cable gland 1

While continuing to gently push the cable forward to keep the braid or armour in contact with the Cone (2), tighten the Body (4) first by hand and then with a spanner until the Body (4) is fully tightened onto the Entry Component (1) and no threads are visible. Use threadlocker.

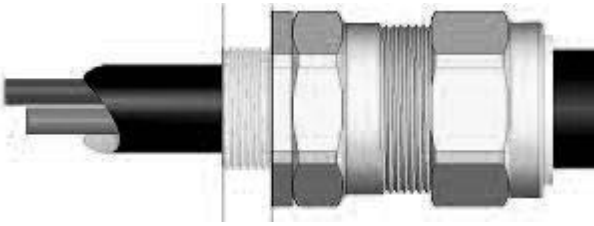

Figure 3.3 – Installation of the cable gland 2

Only using finger pressure, tighten the Outer Seal Nut Assembly (5) until light resistance to tightening is met. Use threadlocker. Tighten the seal using a spanner.

For more detailed informations please also note the installation instructions for CMP cable gland types C2K:

<https://www.cmp-products.com/glands/products/explosive-atmosphere/c2k-explosive-atmosphere-cable-gland/>

3.3 Connecting the cable to the clamps

At first connect the grounding wire. Corresponding to the color code of the already connected camera cable, also the wires of the cable kit are connected so that the colors match. Please do not untie the twisted pair network and put the shielding braid as close to the clamps as possible. Tidily strip the ends of the wires and mount them firmly.

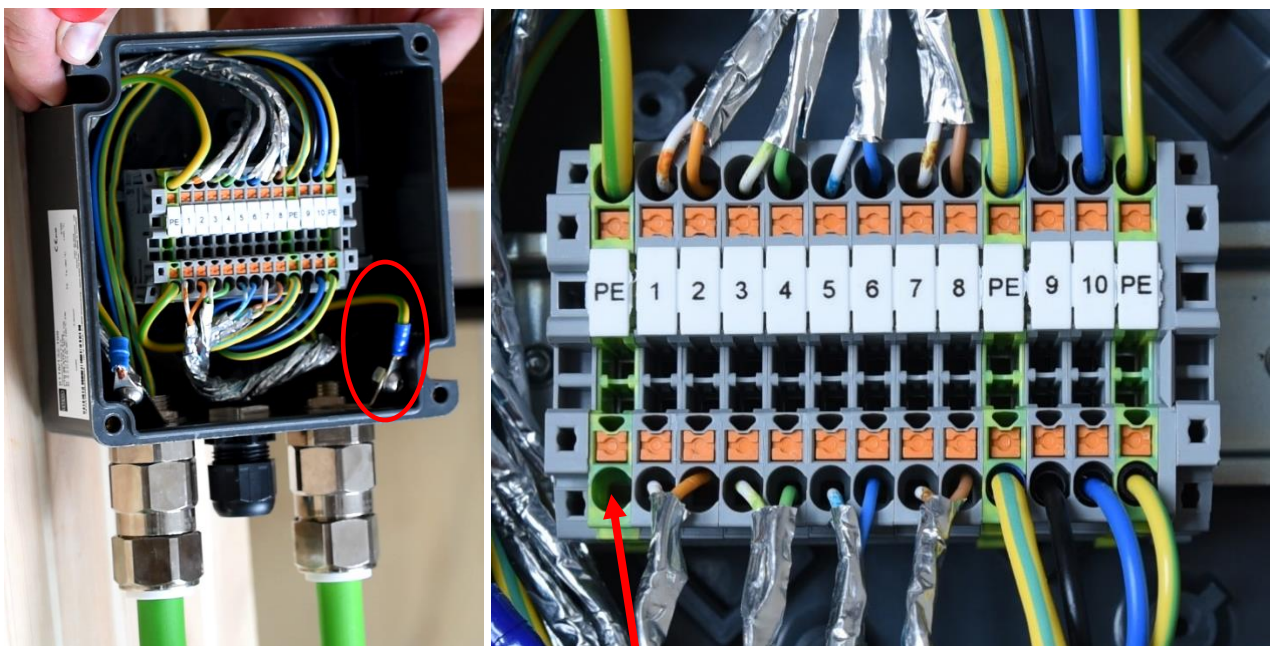

Figure 3.2 – Connection in the terminal box

Grounding Cable

On YouTube you will find precise instructions on the cable configuration and the connection inside the terminal box ExTB-3 at: <https://go.samcon.eu/v04>



4 Insertion into Ex d

In this chapter the connection to the ExConnection Rail is described.

4.1 Components of the cable gland Ex d

The used cable gland for armoured cables for insertion into Ex d (further referred to as Capri cable gland) is shown on Fig. 1.1 (c).

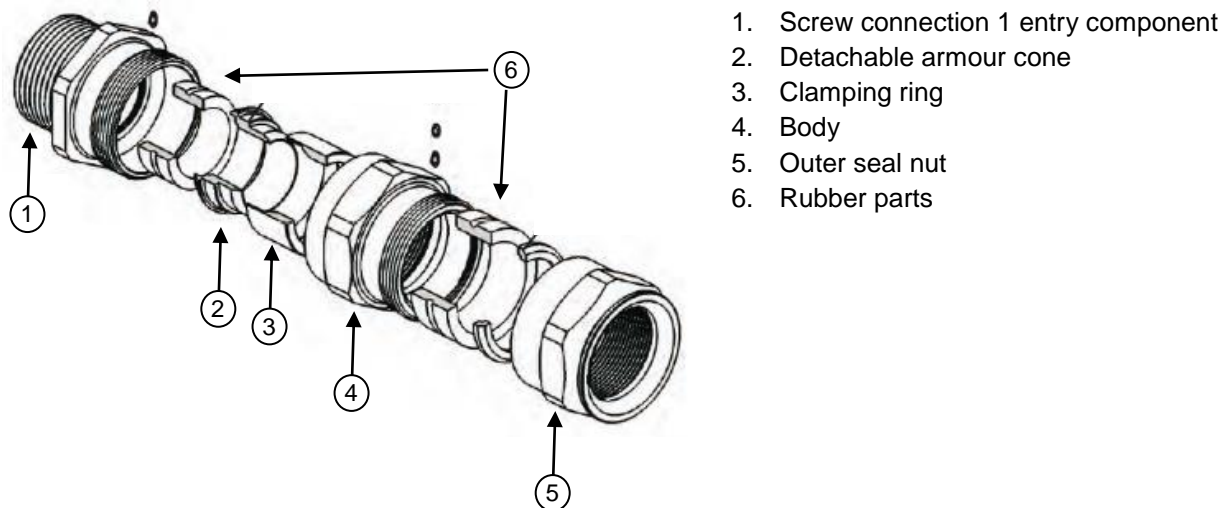

Figure 4.1 – Components of the Capri cable gland

4.2 Installation of the cable gland Ex d for armoured cables

Remove the plug at the bottom left of the ExConnection Rail. Put threadlocker onto screw connection 1. Tighten the screw connection with a torque of 20 N/m. Loosen the other components of the Capri cable gland and separate them. Remove the middle circles of the two rubber parts (6) by using a sharp item. Push the components of the cable gland over the cable, Outer seal assembly (5) first. Push the Cone (2) under the shielding braid and insert the cable into the ExConnection Rail. Ensure that the copper wire shielding is over the Cone (2). Push the Clamping ring (3) and then the other components forward. Securely screw all components together using threadlocker. Tighten the Body (4) and the Outer seal nut (5) with a torque of 30 N/m. Please also consider the Capri instructions:

<http://www.cooperindustries.com/content/dam/public/crousehinds/resources/pdfs/instruction-sheets/ade5f-assemblyinstructions.pdf>

For more detailed instructions on how to set up the cable gland (insertion into Ex d) please refer to our YouTube tutorial: <https://go.samcon.eu/v05>



5 Connecting the RJ 45 plug (Ex d or non-ex)

Strip off 25 cm of the cable insulation as described in chapter 3.1. Please make sure that the insulation foil (7) is not damaged.

The plug is connected according to EIA/TIA-568B (q.v. attached sketch).

The cables of the same color will be put through the applicable opening and then cut off flush at the front. It is important that the shielding is lead through until it touches the shielding clamp.

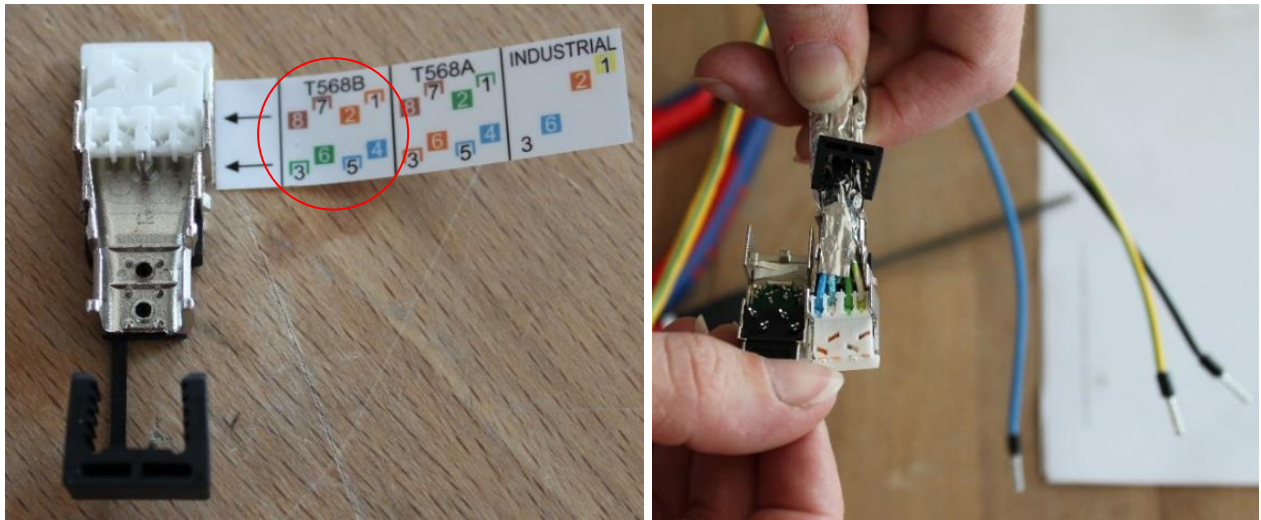

Figure 5.1 – Connecting the RJ 45 plug

Press the plug together with a gripper until it snaps and remove the piece of paper.

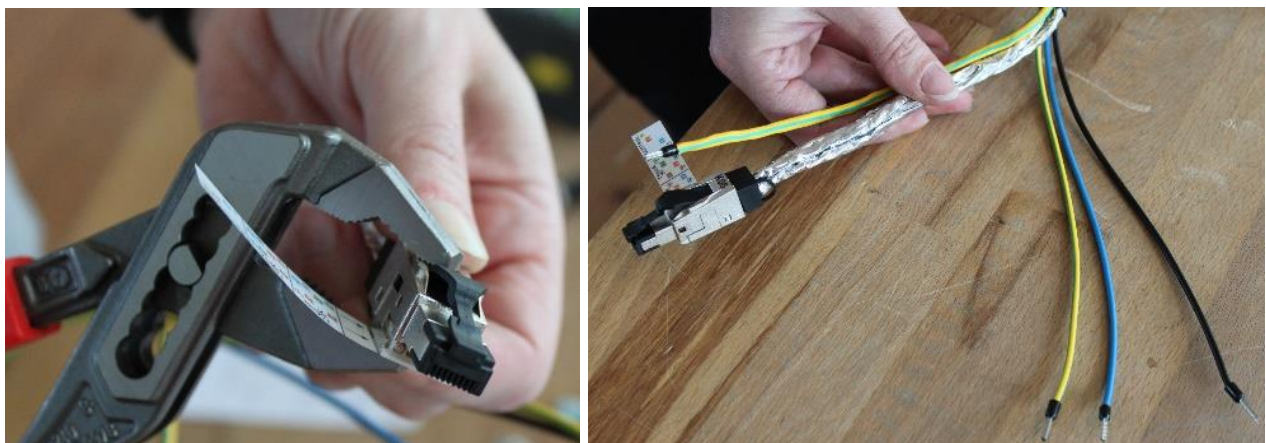

Figure 5.2 – Completed cable with a RJ 45 plug

For detailed instructions regarding the connection of the RJ 45 plug please refer to our YouTube tutorial: <https://go.samcon.eu/v03>



6 Connecting the power channel (24VDC)



Attention!

Please observe the national regulations regarding security, installation, and accident prevention (e.g. IEC 60079-14)!

External power supply (Input voltage):	100 VAC – 240 VAC
Connection data input (Conductor cross-section):	Solid min. 0.2 mm ² , max. 6 mm ² Flexible min. 0.2 mm ² , max. 4 mm ²
External fuse:	C6A
Outer cable diameter:	11.1 mm to 20.0 mm

7 Support / contact

If you have any questions or if you need our support please contact us at:

Mail: support@samcon.eu

Tel.: +49 6426 9231-0

<https://www.samcon.eu/en/contact/>

8 Notes



design: carson grey@liquiverse.com
printed in germany



SAMCON
Prozessleittechnik GmbH

Schillerstrasse 17, 35102 Lohra-Altenvers
www.samcon.eu, info@samcon.eu
fon: +49 6426 9231-0, fax: - 31