

AXIS C1310-E Mk II Network Horn Speaker

Outdoor speaker for clear long-range speech

AXIS C1310-E Mk II Network Horn Speaker is perfect for outdoor environments in most climates. It allows users to remotely prevent unwanted activities, to deliver instructions during an emergency or to make general voice messages. Built-in memory supports pre-recorded messages, or security personal can respond to notifications with live speak. Open standards support easy integration with network video, access control, analytics, and VoIP (supporting SIP). Digital signal processing (DSP) ensures clear sound. The built-in microphone enables remote health testing and 2-way communication. Furthermore, the embedded audio management software supports user, content, zone, and scheduling management.

- > **All-in-one speaker system**
- > **Connects to standard network**
- > **Simple installation with PoE**
- > **Remote health testing**
- > **Scalable and easy to integrate**



AXIS C1310-E Mk II Network Horn Speaker

System on chip (SoC)

Model	i.MX 8M Nano
Memory	1024 MB RAM, 1024 MB Flash

Audio hardware

Enclosure	Re-entrant horn loudspeaker with compression driver
Max sound pressure level	>121 dB
Frequency response	280 Hz - 12.5 kHz
Coverage pattern	70° horizontal by 100° vertical (at 2 kHz)
Audio input/output	Built-in microphone (can be disabled mechanically) Built-in speaker
Built-in microphone specification	50 Hz - 12 kHz
Digital signal processing	Built-in and pre-configured
Amplifier description	Built-in 7 W Class D amplifier

Audio management

AXIS Audio Manager Edge	Built in: <ul style="list-style-type: none"> Content management for music and live/pre-recorded announcements. Scheduling to decide when and where to play specific content. Content prioritization to ensure urgent messages interrupt the schedule. Zone management allowing you to divide up to 200 speakers into 20 zones. Health monitoring for remote discovery of system errors. User management to control who has access to what features. See separate datasheet for more details.
AXIS Audio Manager Pro	For larger and more advanced systems. Sold separately. See separate datasheet for specifications.
AXIS Audio Manager Center	AXIS Audio Manager Center is a cloud service for remote access and management of multi-site systems.

Audio software

Audio streaming	One-way/two-way with optional half-duplex echo cancellation. Mono.
Audio encoding	AAC LC 8/16/32/48 kHz, G.711 PCM 8 kHz, G.726 ADPCM 8 kHz, Axis μ -law 16 kHz, WAV, MP3 in mono/stereo from 64 kbps to 320 kbps. Constant and variable bit rate. Sampling rate from 8 kHz up to 48 kHz.

Network

Network protocols	IPv4, IPv6 USGv6, ICMPv4/ICMPv6, HTTP, HTTPS ^a , HTTP/2, TLS ^a , QoS Layer 3 DiffServ, FTP, SFTP, CIFS/SMB, SMTP, mDNS (Bonjour), UPnP [®] , SNMP v1/v2c/v3 (MIB-II), DNS/DNSv6, DDNS, NTP, NTS, RTSP, RTP, SRTP/RTSPS, TCP, UDP, IGMPv1/v2/v3, RTCP, ICMP, DHCPv4/v6, ARP, SSH, LLDP, CDP, MQTT v3.1.1, Secure syslog (RFC 3164/5424, UDP/TCP/TLS), Link-Local address (ZeroConf), IEEE 802.1X (EAP-TLS), IEEE 802.1AR
-------------------	--

System integration

Application Programming Interface	Open API for software integration, including VAPIX [®] , metadata and AXIS Camera Application Platform (ACAP); specifications at axis.com/developer-community . ACAP includes Native SDK. One-click cloud connection. Support for Session Initiation Protocol (SIP) for integration with Voice over IP (VoIP) systems, peer to peer or integrated with SIP/PBX.
Video management systems	Compatible with AXIS Companion, AXIS Camera Station, video management software from Axis' Application Development Partners available at axis.com/vms
Intelligent audio	Auto Speaker Test
Event conditions	Audio: audio clip playing, speaker test result Device status: IP address blocked/removed, live stream active, network lost, new IP address, system ready Edge storage: recording ongoing, storage disruption, storage health issues detected

I/O: digital input, manual trigger, virtual input
 MQTT: subscribe
 Scheduled and recurring: schedule

Event actions	Audio: run automatic speaker test Audio clips: play, stop I/O: toggle I/O Light and siren: run, stop MQTT: publish Notification: HTTP, HTTPS, TCP and email Recordings: record audio SNMP trap messages: send message Status LED: flash
---------------	---

Built-in installation aids	Test tone verification and identification
----------------------------	---

Functional monitoring	Auto Speaker Test, Connection verification, Built-in system logging
-----------------------	---

Approvals

Product markings	CSA, UL/cUL, UKCA, CE, KC, EAC, VCCI, RCM
Supply chain	TAA compliant
EMC	EN 55035, EN 55032 Class B, EN 50121-4, EN 61000-6-1, EN 61000-6-2 Australia/New Zealand: RCM AS/NZS CISPR 32 Class B Canada: ICES-3(B)/NMB-3(B) Japan: VCCI Class B Korea: KS C 9835, KS C 9832 Class B USA: FCC Part 15 Subpart B Class B Railway: IEC 62236-4

Safety	CAN/CSA C22.2 No. 62368-1 ed. 3, IEC/EN/UL 62368-1 ed. 3
--------	--

Environment	IEC 60068-2-1, IEC 60068-2-2, IEC 60068-2-14, IEC 60068-2-27, IEC 60068-2-78, IEC 62262 IK09, IEC/EN 60529 IP66, NEMA 250 Type 4X, MIL-STD-810G 509.5, MIL-STD-810H 509.7
-------------	---

Cybersecurity	ETSI EN 303 645
---------------	-----------------

Cybersecurity

Edge security	Software: Signed firmware, brute force delay protection, digest authentication, password protection Hardware: Axis Edge Vault cybersecurity platform Secure element (CC EAL 6+), Axis device ID, secure keystore, secure boot
---------------	---

Network security	IEEE 802.1X (EAP-TLS) ^a , IEEE 802.1AE (MACsec PSK/EAP-TLS), IEEE 802.1AR, HTTPS/HSTS ³ , TLS v1.2/v1.3 ^a , Network Time Security (NTS), X.509 Certificate PKI, host-based firewall
------------------	--

Documentation	<i>AXIS OS Hardening Guide</i> <i>Axis Vulnerability Management Policy</i> <i>Axis Security Development Model</i> AXIS OS Software Bill of Material (SBOM) To download documents, go to axis.com/support/cybersecurity/resources To read more about Axis cybersecurity support, go to axis.com/cybersecurity
---------------	---

General

Casing	IP66- and NEMA 4X-rated Aluminum back can and stainless steel bracket Color: white RAL 9010
Power	Power over Ethernet (PoE) IEEE 802.3af/802.3at Type 1 Class 3 Typical 2 W, max 12.95 W
Connectors	Network: RJ45 10BASE-T/100BASE-TX PoE I/O: 4-pin 2.5 mm terminal block for 2x supervised configurable I/Os
Reliability	Designed for 24/7 operation.
Operating conditions	Temperature: -40 °C to 60 °C (-40 °F to 140 °F) Humidity: 10-100% RH (condensing)
Storage conditions	Temperature: -40 °C to 65 °C (-40 °F to 149 °F) Humidity: 5-95% RH (non-condensing)
Dimensions	For the overall product dimensions, see the dimension drawing in this datasheet.
Weight	1.3 kg (2.9 lb.)

Box content	Horn speaker, installation guide, terminal block connector, connector guard, cable gasket, ring terminal, owner authentication key
Optional accessories	AXIS T91B47 Pole Mount, AXIS T91F67 Pole Mount, Cable Gland M20x1.5, RJ45, Cable Gland A M20, AXIS Power over Ethernet Midspans, T94R01B Corner Bracket, T94P01B Corner Bracket, T94S01P Conduit Back Box For more accessories, go to axis.com/products/axis-c1310-e-mk-ii#accessories
Languages	English, German, French, Spanish, Italian, Russian, Simplified Chinese, Japanese, Korean, Portuguese, Polish, Traditional Chinese, Dutch, Czech, Swedish, Finnish, Turkish, Thai, Vietnamese
Warranty	5-year warranty, see axis.com/warranty
Part numbers	Available at axis.com/products/axis-c1310-e-mk-ii#part-numbers

Sustainability

Substance control PVC free in accordance with JEDEC/ECA Standard JS709
RoHS in accordance with EU RoHS Directive 2011/65/EU/ and EN 63000:2018
REACH in accordance with (EC) No 1907/2006. For SCIP UUID, see echa.europa.eu

Materials Screened for conflict minerals in accordance with OECD guidelines
To read more about sustainability at Axis, go to axis.com/about-axis/sustainability

Environmental responsibility axis.com/environmental-responsibility
Axis Communications is a signatory of the UN Global Compact, read more at unglobalcompact.org

- a. *This product includes software developed by the OpenSSL Project for use in the OpenSSL Toolkit. (openssl.org), and cryptographic software written by Eric Young (eay@cryptsoft.com).*

Dimension drawing

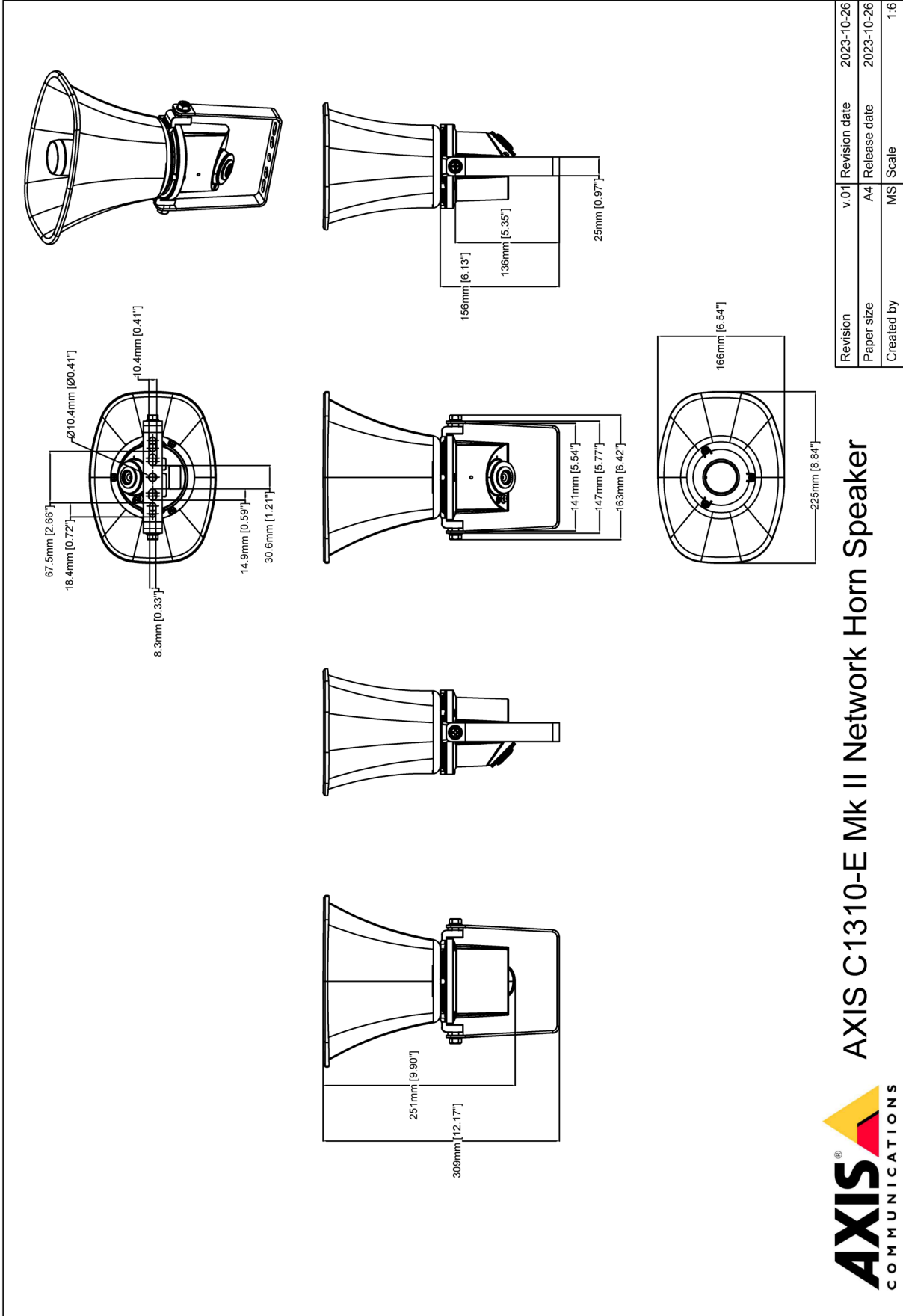

© 2023 Axis Communications



AXIS C1310-E Mk II Network Horn Speaker

www.axis.com

Highlighted capabilities

Axis Edge Vault

Axis Edge Vault is the hardware-based cybersecurity platform that safeguards the Axis device. It forms the foundation that all secure operations depend on and offer features to protect the device's identity, safeguard its integrity and protect sensitive information from unauthorized access. For instance, **secure boot** ensures that a device can boot only with **signed OS**, which prevents physical supply chain tampering. With signed OS, the device is also able to validate new device software before accepting to install it. And the **secure keystore** is the critical building-block for protect-

ing cryptographic information used for secure communication (IEEE 802.1X, HTTPS, Axis device ID, access control keys etc.) against malicious extraction in the event of a security breach. The secure keystore and secure connections are provided through a Common Criteria or FIPS 140 certified hardware-based cryptographic computing module.

To read more about Axis Edge Vault, go to axis.com/solutions/edge-vault.

For more information, see axis.com/glossary