

AXIS T90D Illuminator Series

AXIS T90D20 IR-LED

AXIS T90D20 PoE IR-LED

AXIS T90D25 W-LED

AXIS T90D25 PoE W-LED

AXIS T90D30 IR-LED

AXIS T90D30 PoE IR-LED

AXIS T90D35 W-LED

AXIS T90D35 PoE W-LED

AXIS T90D40 IR-LED

Table of Contents

Eye safety information3
About this manual4
Product overview5
 Product overview5
 Remote control6
 How to configure the wires (only for AC/DC versions).....6
Additional settings.....7
 About the factory default settings.....7
 About operating and programming mode.....7
 How to change from operating to programming mode.....7
 How to change from programming to operating mode.....8
 About using a PIN8
 How to set a PIN8
 How to enter a PIN8
 How to delete a PIN.....8
 How to disable the control buttons8
 How to re-enable the control buttons9
 How to control the illuminator with an Axis network camera.....9
 How to adjust the light intensity.....10
 How to adjust the photocell sensitivity.....10
 How to enable or disable the LED indicators.....11
Reset to factory default settings.....12
Troubleshooting.....13
Specifications.....14
 LED Indicators.....14

Eye safety information

⚠ CAUTION

⚠ IR is emitted from this product. It can be harmful to the eyes. Avoid eye exposure. Use shielding or eye protection.

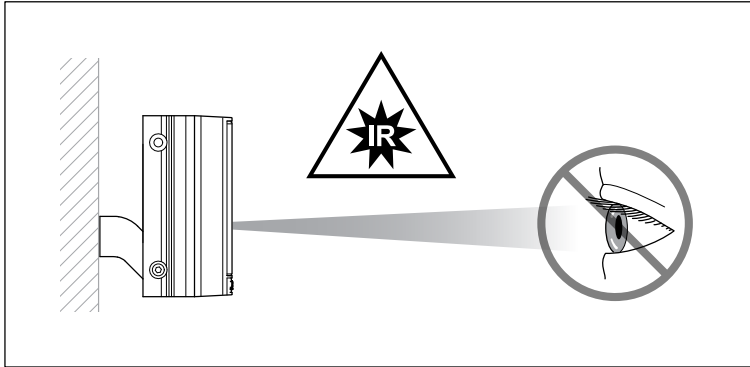

⚠ CAUTION

Possibly hazardous optical radiation is emitted from this product. It can be harmful to the eyes. Don't stare at the operating lamp.

About this manual

This user manual describes several products. This means you may find instructions that aren't applicable to your product.

Product overview

Product overview

Note

The appearance of your product may differ from the following images.

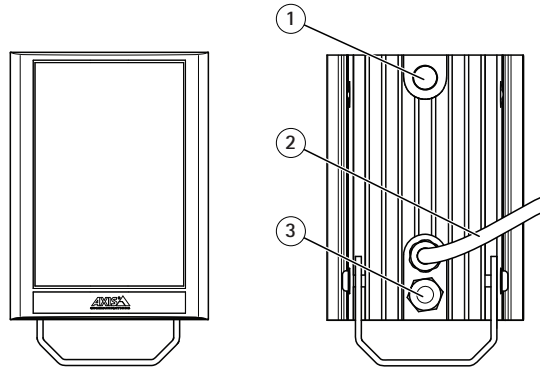

- 1 Photocell
- 2 Power, photocell and telemetry for AC/DC versions or network cable for PoE versions
- 3 Breather gland

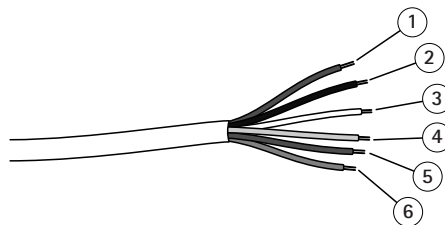

Wire configuration (AC/DC versions only)

- 1 Power wire (red)
- 2 Power wire (black)
- 3 Photocell wire (white)
- 4 Photocell wire (yellow)
- 5 Telemetry wire (purple)
- 6 Telemetry wire (orange)

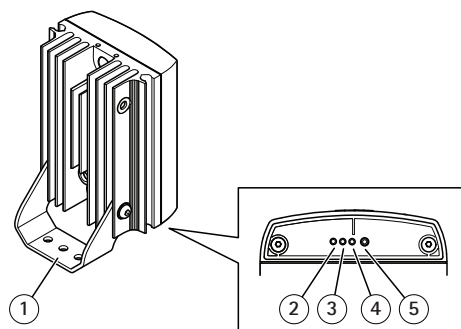

- 1 Mounting bracket (pre-mounted)
- 2 Control button (left)
- 3 Left Hand Side LED (LHS)
- 4 Right Hand Side LED (RHS)
- 5 Control button (right)

The baseplate must be removed in order to access the two control buttons.

Remote control

Note

The remote control is an optional accessory.

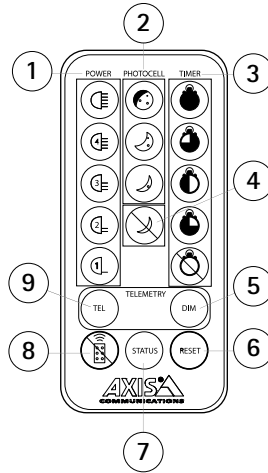

- 1 Power level buttons
- 2 Photocell sensitivity buttons
- 3 Timer buttons
- 4 Photocell disable button
- 5 Telemetry dimming button
- 6 Reset button
- 7 Status button for LED and PIN
- 8 Disable remote control setup button
- 9 Telemetry input button

How to configure the wires (only for AC/DC versions)

Connect the power wires (red and black) to a power source equipment. For more information, see the Installation Guide.

To control the product with an Axis network camera, connect the telemetry wires to the camera's I/O connector. Connect the purple telemetry wire to pin 1 (DC ground), and the orange telemetry wire to pin 4 (digital output). For more information, see *How to control the illuminator with an Axis network camera, on page 9*.

To control a camera with the product's photocell, connect the photocell wires (white and yellow) to the camera's I/O connector. Connect one of the wires to pin 1 (DC ground) and the other one to pin 3 (digital input).

Additional settings

About the factory default settings

When you buy the product, the telemetry wires (see *Product overview, on page 5*) are soldered together. This makes the illuminator turn on automatically when the photocell detects low-light conditions.

When you connect the product for the first time, it has the following settings:

- Light intensity: 100%
- Photocell sensitivity: 10 Lux on, 30 Lux off
- LED indicators: on
- PIN set: no
- Control buttons: enabled
- Mode: programming mode (changes to operating mode seven days after start-up if you don't press any control buttons)

About operating and programming mode

The product has two different modes, operating and programming. You can access different settings depending on which mode the product is in.

Setting	Remote control		Control buttons		More information
	Operating mode	Programming mode	Operating mode	Programming mode	
Adjust light intensity		x	x	x	See page 10.
Adjust photocell sensitivity		x	x	x	See page 10.
Enable or disable LED indicators	x	x	x	x	See page 11.
Disable control buttons	x		x	x	See page 8.

To minimize the risk of tampering, we recommend you to set the product to operating mode when the illuminator has been set up and is delivering the required operating performance.

How to change from operating to programming mode

With a preset PIN

- Enter the PIN. See *How to enter a PIN, on page 8*.
- Do a full reset. See *Reset to factory default settings, on page 12*.

Without a preset PIN

- Disconnect and reconnect the product to power.
- With the control buttons:
 1. Press and hold the left control button for 4 seconds until the left hand side LED flashes red.
 2. Press the left control button once more so that the left hand side LED flashes green.
 3. Press the right control button repeatedly until the right hand side LED turns solid green.

How to change from programming to operating mode

With the remote control

1. Press and hold the Disable remote control setup button for 4 seconds.

With the control buttons

1. Press and hold the left control button for 4 seconds until the left hand side LED flashes red.
2. Press the left control button once more so that the left hand side LED flashes green.
3. Press the right control button repeatedly until the right hand side LED turns solid red.

If you don't press any control buttons, the product automatically changes to operating mode after 7 days. If you do press a control button, it changes to operating mode after 30 minutes.

About using a PIN

If you have the optional remote control, you can set a PIN. Use the PIN to:

- change from operating to programming mode
- temporarily re-enable the control buttons if they are disabled

If you forget your PIN, you need to do a full reset. See *Reset to factory default settings, on page 12.*

How to set a PIN

1. When the product is in programming mode, press and hold the Status button for 4 seconds until the left hand side LED flashes red/green.
2. Enter a 4-character PIN using buttons A-E.

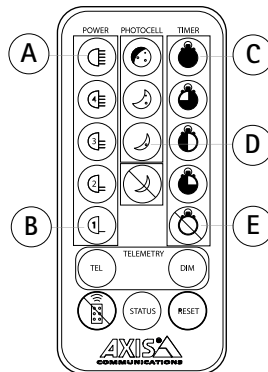

When you have set the PIN, the product returns to programming mode.

How to enter a PIN

1. Press and hold the Status button for 4 seconds until the left hand side LED flashes red/green.
2. Enter PIN.

If you enter the wrong PIN, both LEDs will flash red.

How to delete a PIN

1. When the product is in programming mode, press and hold the Status button for 4 seconds.
2. Press the Reset button four times.

How to disable the control buttons

With the remote control

1. Within 5 minutes after you enter operating mode, press and hold the Disable remote control setup button for 4 seconds.

With the control buttons

1. Press and hold the left control button for 4 seconds until the left hand side LED flashes red.
2. Press the left control button twice so that the left hand side LED flashes amber.
3. Press the right control button repeatedly until the right hand side LED turns solid red.

Note

You can reverse this setting with the control buttons within 30 minutes:

1. Press and hold the left control button for 4 seconds until the left hand side LED flashes red.
2. Press the left control button twice so that the left hand side LED flashes amber.
3. Press the right control button repeatedly until the right hand side LED turns solid green.

How to re-enable the control buttons

If the control buttons are disabled, you can re-enable them temporarily (for 30 minutes) or permanently.

Temporarily with a preset PIN

- Enter the PIN. See *How to enter a PIN, on page 8*.

Temporarily without a preset PIN

- Disconnect and reconnect the product to power.

Permanently with or without a preset PIN

- Do a full reset. See *Reset to factory default settings, on page 12*.

How to control the illuminator with an Axis network camera

This use case explains how to:

- connect the illuminator to the I/O connector of an Axis network camera
- set up the camera to make the illuminator turn on when the camera detects motion

Connect the illuminator to an Axis network camera:

1. Snip the end of the telemetry wires (purple and orange) to separate them.
2. Connect the purple wire to pin 1 (DC ground) of the camera's I/O connector. If you need more information about the camera's I/O connector, see the camera's User Manual.
3. Connect the orange wire to pin 4 (digital output) of the camera's I/O connector.

Configure the I/O port in the camera's webpage:

1. Go to **Settings > System > I/O ports**.

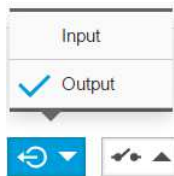

2. Select **Output** in the **Port 2** drop-down list.
3. Give the output module a descriptive name, for example "Illuminator".
4. To make the illuminator turn on when the camera detects motion, select **Open circuit** in the drop-down



list.

Verify in the camera's webpage that the AXIS Video Motion Detection application is running:

1. Go to **Settings > Apps > AXIS Video Motion Detection**.
2. Start the application if it is not already running.
3. Make sure you have set up the application according to your needs.

Create an action rule in the camera's webpage, to make the illuminator turn on when the camera detects motion:

1. Go to **Settings > System > Events > Action rules** and add an action rule.
2. Give the action rule a descriptive name, for example "Turn on illuminator".
3. From the list of triggers, select **Applications** and then select the motion detection application.
4. From the list of actions, select **Output port** and then select **Output 2**.
5. Click **OK**.

The illuminator will now turn on whenever the camera detects motion.

How to adjust the light intensity

There are five predefined levels of light intensity.

With the remote control

Use the power level buttons to select the required light intensity.

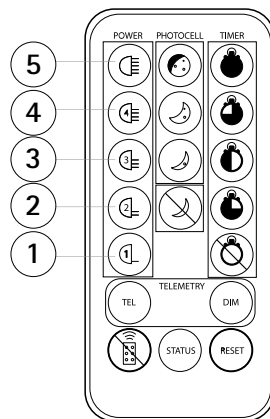

- 1 20% of maximum
- 2 40% of maximum
- 3 60% of maximum
- 4 80% of maximum
- 5 100% of maximum

With the control buttons

1. Press the left control button once so that the left hand side LED turns solid red.
2. Press the right control button repeatedly. The right hand side LED indicates the light intensity level:
 - one green flash: 20% of maximum.
 - two green flashes: 40% of maximum.
 - three green flashes: 60% of maximum.
 - four green flashes: 80% of maximum.
 - five green flashes: 100% of maximum.

How to adjust the photocell sensitivity

The photocell sensitivity level decides at which lux level thresholds the illuminator turns on and off. There are three predefined levels.

Note

If you disable the photocell, the illuminator turns on and off from a telemetry input regardless of ambient lighting conditions.

With the remote control

Use the photocell sensitivity buttons to select the required sensitivity level.

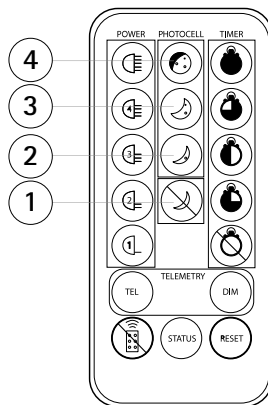

- 1 Photocell disabled
- 2 5 lux on, 15 lux off
- 3 10 lux on, 30 lux off
- 4 25 lux on, 50 lux off

With the control buttons

1. Press the left control button twice so that the left hand side LED turns solid green.
2. Press the right control button repeatedly. The right hand side LED indicates the sensitivity level:
 - one green flash: 5 lux on, 15 lux off.
 - two green flashes: 10 lux on, 30 lux off.
 - three green flashes: 25 lux on, 50 lux off.
 - solid red: photocell disabled.

How to enable or disable the LED indicators

With the remote control

1. Press the Status button to enable or disable the LED indicators.

With the control buttons

1. Press the left control button three times so that the left hand side LED turns solid amber.
2. Press the right control button repeatedly. The right hand side LED indicates whether the LED indicators are enabled or disabled:
 - solid green: LED indicators are enabled.
 - solid red: LED indicators are disabled.

Reset to factory default settings

You can choose to make a full reset or a settings reset. The full reset restores factory default settings and removes the PIN if one has been set. The settings reset restores factory default settings but keeps the PIN, and returns the illuminator to the mode it was in before the reset.

Settings reset with remote control

1. When the product is in programming mode, press and hold the reset button for 4 seconds.

Settings reset with control buttons

1. Press and hold the left control button for 4 seconds until the left hand side LED turns flashing red.
2. Press and hold the right control button for 4 seconds. The right hand side LED stays solid red during that time. After 4 seconds, both LEDs flash amber.

Full reset with control buttons

1. Press and hold both control buttons while disconnecting and reconnecting power.

Troubleshooting

Ensure all tests are undertaken by a qualified, trained engineer.

Ensure safe working practices are followed at all times.

- **Basics**
 - Check the LED indicators. See *LED Indicators, on page 14*.
 - Check the polarity of the illuminator connection: red = +ve, black = -ve.
 - Ensure the illuminator uses the correct power range.
 - Ensure the power supply is suitably rated for the product.
 - Ensure the telemetry wires are short-circuited or valid telemetry input is applied and correctly wired.
 - Check that the photocell is working. If you cover the photocell fully, light should turn on. It can be difficult to see infra-red illuminators working in high brightness conditions.
- **Illuminator test**

Note

Use the appropriate multimeter depending on how the illuminator is powered. Cover the photocell fully (or disable the photocell using the optional remote control) and make sure the telemetry wires are short-circuited or closed contact input (zero volt) is applied.

- Check that the current is being drawn. The amount of current depends on the power setting of the illuminator.
- **Set up camera, lens and illumination**
 - Make sure the power is set to maximum.
 - Check the orientation of illuminator and make sure it is pointing in the correct direction
 - Check the angle of the diverging lens. A too narrow angle may cause hot spots and the aperture of the camera lens to close down. A too wide angle may cause insufficient light on the scene.
- **Remote Control (optional accessory)**
 - Press the Status button to check the status of the remote control, see *How to enable or disable the LED indicators, on page 11*.
 - The illuminator might be in operating mode. See *About operating and programming mode, on page 7*.
 - In bright sunlight, the distance between the remote control and the illuminator may need to be reduced.
 - Check the battery on the remote control (CR2025) and replace if necessary.
 - Make sure no other strong infra-red source is pointing at the remote receiver.
 - Make sure there is a clear line of sight between the illuminator and the remote control.

Specifications

LED Indicators

There are two colored LED indicators on the base of the illuminator which provide operating and status information.

Left hand side LED	Indication
Solid green	Power on.
Solid red	Illuminator fault detected.
Flashing red	Voltage supply problem detected.

Right hand side LED	Indication
Flashing amber	Illuminator is in Programming Mode.

T10116700

2026-06 (M4.2)

© 2017 – 2026 Axis Communications AB