

## **AXIS D2210-VE Radar**

## **Repainting instructions**

# AXIS D2210-VE Radar

## Impact on warranty

---

### Impact on warranty

This product is approved for repaint by Axis, provided that you follow the instructions in this document and at [axis.com/warranty-implication-when-repainting](https://axis.com/warranty-implication-when-repainting).

### Risks with repainting

There are several risks when disassembling or assembling an Axis product. There is always a certain yield loss during assembly. Training of operators and the use of correct tools mediates some of the problems but they can never be fully avoided. Some of the risks include:

**ESD Damage** – Always handle the product in an ESD safe environment. Even if precautions are taken there is always a risk of ESD damage. The damage can remain undetected and cause problems during the lifetime of the equipment.

**Paint overspray** – Masking the different components of the equipment is critical. Failure to mask sensitive areas can cause problems with assembling the equipment. Any areas that are not painted at factory or have a different surface treatment than the rest of the parts (threads, ground and electrical contact surfaces) must also be masked to ensure function.

# AXIS D2210-VE Radar

## Repaint the product

---

### Repaint the product

#### Preparations

- If applicable, disassemble the device according to the instructions in this document.
- Clean all parts that will be repainted thoroughly to remove grease, dust, or oil.
- To ensure reassembly and functionality of the product, mask any openings (for example for screws, LED indicators, or microphones) before you paint.

#### Pretreatment of parts

Depending on the part material and type of coating applied at factory, pretreatment might be necessary for the new coating to adhere well. Before you apply a new coating, we recommend the following pretreatment:

1. If necessary, roughen up the surface with a light sandpaper or similar to increase adhesion. Alternatively, remove the original coating down to base material.
2. Clean the parts properly to remove oil, grease, and dust.
3. If necessary, apply a primer layer suitable for the specific material to increase adhesion to the parts. For outdoor products, we recommend a primer to improve corrosion resistance.

We recommend pretreatment of parts made of the following materials:

- powder coated
- wet painted
- anodised
- chromated
- stainless steel
- other metal
- plastic

The materials used in this product are:

- Powder coated aluminum

#### Disassembly

Disassemble the wall mount

# AXIS D2210-VE Radar

## Repaint the product

---

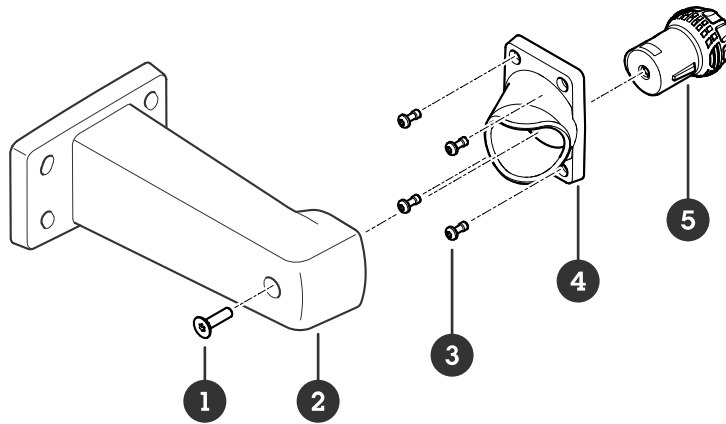

- 1 Screw
- 2 Arm
- 3 Screw (4x)
- 4 Bracket
- 5 Ball

1. Remove the torx screw at the bottom of the arm.
2. Remove the four screws from the bracket.
3. Remove the ball from the bracket.

# AXIS D2210-VE Radar

## Repaint the product

---

### Masking

#### Masking the radar

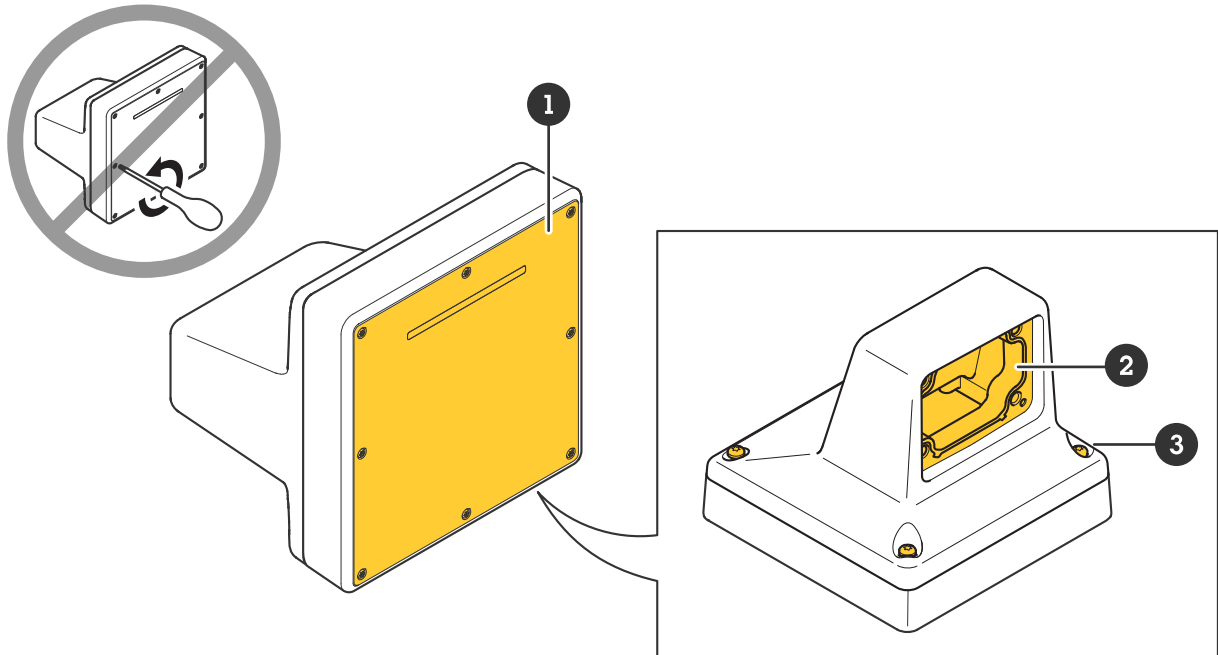

- 1 Radome
- 2 Inside of chassis
- 3 Screw (4x)

#### Important

Do not remove the radome from the radar.

Mask the following parts of the radar:

1. The radome.
2. The inside of the chassis, including the gasket and four screw holes.
3. The four screws.

# AXIS D2210-VE Radar

## Repaint the product

---

### Masking the wall mount bracket

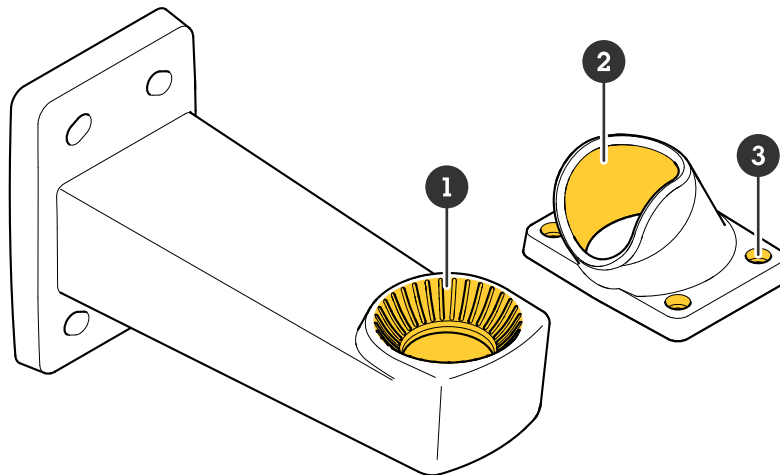

- 1 Recess
- 2 Bracket inside
- 3 Screw hole (4x)

Mask the following parts:

- 1. The recess of the arm.
- 2. The inside of the bracket.
- 3. The four screw holes.

### Repainting

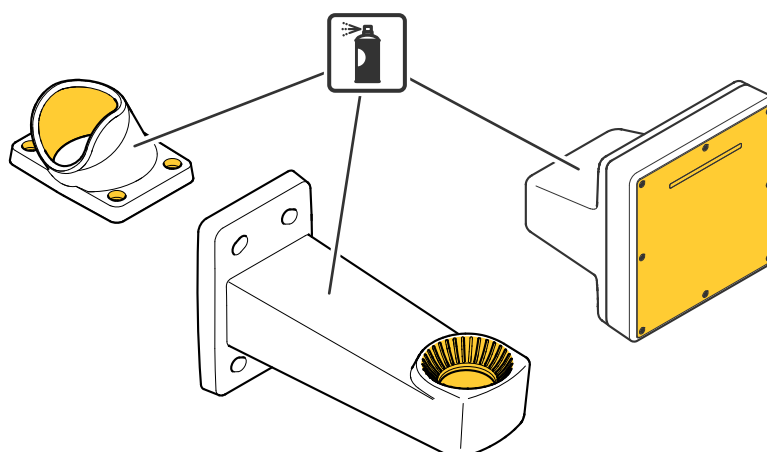

- 1. Make sure you have made all necessary preparations of the parts to be repainted, see *Preparations on page 3*.
- 2. Apply a thin and even layer of spray paint according to the instructions of the paint manufacturer.
- 3. Let the paint dry according to the paint manufacturer's recommendations.

# AXIS D2210-VE Radar

## Repaint the product

---

4. To get a better coverage and clearer color, apply a second layer of spray paint.
5. When the paint is dry, reassemble the product.

### Reassembly

Reassemble the product.

For more information, see the installation guide available at [axis.com](http://axis.com)

