AXIS 5500/AXIS 5550

Network Print Servers

User's Manual

Regulatory Information

Safety Notices Take some time to read through the safety notices before installing the AXIS 5500/AXIS 5550. Please observe all safety markings and instructions when using this product.

Important: Observe "Important:" in the text to avoid operational impairment. Do not proceed until you have fully understood the implications.

Electromagnetic Compatibility (EMC)



USA This equipment has been tested and found to comply with the limits for a Class B digital device, pursuant to Part 15 of the FCC Rules. These limits are designed to provide reasonable protection against harmful interference in a residential installation. This equipment generates, uses and can radiate radio frequency energy and, if not installed and used in accordance with the instructions, may cause harmful interference to radio communications. However, there is no guarantee that interference will not occur in a particular installation. If this equipment does cause harmful interference to radio or television reception, which can be determined by turning the equipment off and on, the user is encouraged to try to correct the interference by one or more of the following measures:

- reorient or relocate the receiving antenna
- increase the separation between the equipment and receiver
- connect the equipment into an outlet on a circuit different from that to which the receiver is connected
- consult the dealer or an experienced radio/TV technician for help. Shielded (STP) network cables must be used with this unit to ensure compliance with the class B limits..

Europe This digital equipment fulfils the requirements for radiated emission according to limit B of EN55022, and the requirements for immunity according to EN55024 residential, commercial, and light industry. Compliance is not valid for unshielded network cables.

Japan This is a class B product based on the standard of the Voluntary Control Council for Interference from Information Technology Equipment (VCCI). If this is used near a radio or television receiver in a domestic environment, it may cause radio interference. Install and use the equipment according to the instruction manual. Compliance is not valid for unshielded network cables.

Australia This electronic device meets the requirements of the Radio communications (Electromagnetic Compatibility) Standard 1998 AS/NZS 3548. Compliance is not valid for unshielded network cables.

Liability Every care has been taken in the preparation of this manual; if you detect any inaccuracies or omissions, please inform your local Axis office, which can be found on the cover of this document. Axis Communications AB cannot be held responsible for any technical or typographical errors and reserves the right to make changes to the product and manuals without prior notice. Axis Communications AB makes no warranty of any kind with regard to the material contained within this document, including, but not limited to, the implied warranties of merchantability and fitness for a particular purpose. Axis Communications AB shall not be liable nor responsible for incidental or consequential damages in connection with the furnishing, performance or use of this material.

Axis' Trademarks AXIS IP JumpStarter, AXIS ThinWizard, axinstall, AXIS Print Monitor, AXIS AddPrinter.

Other Trademark Acknowledgments Adobe Acrobat Reader, Aix, Apple, ARP, BOOTP, Debian, Ethernet, EtherTalk, IBM, LAN Manager, LAN Server, Macintosh, Microsoft, Novell NetWare, OS/2, OS/400, AS/400, Red Hat, Solaris, SuSe, UNIX/Linux, Windows, are registered trademarks of the respective holders.

Support Services Should you require technical assistance, please contact your Axis dealer. If your questions cannot be answered immediately, your Axis dealer will forward your queries through the appropriate channels to ensure you a rapid response. On the Internet you can find on-line manuals, technical support, software updates, application software, corporate information, etc..

Patent information Axis AB has intellectual property rights relating to technology embodied in the product that is described in this document. In particular, and without limitation, these intellectual property rights may include one or more of the patents listed at <http://www.axis.com/patent.htm> and one or more additional patents or pending patent applications in the US and other countries.

Software Acknowledgments This product includes software developed by the OpenSSL Project for use in the OpenSSL Toolkit.

USER'S MANUAL AXIS 5500/AXIS 5550 EN

Part No: 22996, Revision 3.0a

Date: August 2005 - Copyright © Axis Communications AB, 2005

This manual applies to the AXIS 5500/AXIS 5550 with firmware version 7.00 or higher.

Table of Contents

Section 1	Introduction	6
	About this Manual	6
	About Axis	6
	Support Services	6
	Supported Environments	7
Section 2	Product Overview	8
	Package Contents	8
	AXIS Network Product CD	9
	Physical Description	10
	Mounting the AXIS 5500/AXIS 5550	11
	Features and Benefits	11
Section 3	Basic Installation	13
	Quick Overview	13
	Connecting the Hardware	13
	Assigning an IP Address to the Print Server	15
	Making Network Printers available for printing on your PC 21	
Section 4	Adding Printers in Windows	23
	Adding Printers in Windows 2000 / XP / 2003 using AXIS AddPrinter Wizard	24
	Adding Printers in Windows 2000 / XP / 2003 using Windows Add Printer Wizard	26
	Adding Printers in Windows NT using the Microsoft LPR Monitor	29
	Adding Printers in Windows 2000 / XP / 2003 using the Microsoft LPR Monitor	31
	AXIS Print Monitor Software	33
	Adding NetBIOS/NetBEUI Printers in Windows 2000 using AXIS Print Monitor	34
	Adding Printers over NetBIOS/NetBEUI in Windows NT using AXIS Print Monitor	35
	Adding Printers in Windows 98 and Me over TCP/IP using AXIS Print Monitor	36
	Adding Printers in Windows 98 and Me over NetBIOS/NetBEUI using AXIS Print Monitor	37
Section 5	Adding Printers in Macintosh	39
	Bonjour Printing in Mac OS X	39
	Installation in Mac OS X using AppleTalk	41
	Installation of LPR printing in MAC OS X	41
	Installation on Mac OS 9.1 or older, using AppleTalk	42
	Choosing a Printer	42
Section 6	Adding Printers in NetWare	46
	Setup using NDPS	47

	Setup using iPrint	61
	Basic Setup with AXIS NetPilot	65
	Advanced Installation using AXIS NetPilot	67
	Basic Queue-based printing over IP	69
Section 7	Adding Printers in UNIX/Linux	72
	Print Tools	72
	Typical Invocation via a Windows Manager	73
	Typical Invocation from a Terminal Window	74
	Debian 3.0	75
	Red Hat 7.3	76
	SuSE 8.0	78
	AXIS axinstall Script	79
	Print Methods on TCP/IP Networks	80
Section 8	Adding Printers in OS/2	82
	TCP/IP Printing	82
	NetBIOS/NetBEUI Printing in OS/2	82
Section 9	Updating the Firmware	85
	Upgrading the Firmware	85
	Obtaining the Software	87
Section 10	Management and Configuration	88
	Using a Web browser for Print Server Management ...	88
	Using AXIS ThinWizard for Print Server Management ..	92
	Using FTP for Print Server Management	94
	Using Telnet	96
	Using SNMP	98
	Using Novell Utilities	99
Section 11	Configuration Possibilities	101
	Autodetect Printer Type	101
	Auto-IP	101
	E-mail Notification	102
	IPP (Internet Printing Protocol)	102
	Logical Printers for Customized Printing	111
	Network Speed	118
	NetWare Packet Signature Levels	118
	Flashloading New Firmware into the Print Server ...	119
	Changing Language in the Print Server's Web Interface ..	119
	TCP/IP Restrictions	120
	Enabling Secure Web Services – SSL/TLS	121
	Overriding Port Status	123
	Enabling the SNMPv3 Protocol	124
Section 12	IP Addressing	125
Section 13	The Test Button	129
Section 14	Troubleshooting	130

Section 15	Technical Specification	133
Section 16	The Parameter List	137
	NetWare Parameter Combinations	157
	TCP Ports Opened for Raw Printing	158
	SNMP Device Index	158
Section 17	Glossary	160
	Index	165

Section 1 Introduction

Thank you for purchasing the AXIS 5500/AXIS 5550. This product has been developed to connect your printers anywhere in your network, allowing all network users access to shared printer resources.

About this Manual

This manual is applicable for an AXIS 5500/AXIS 5550 with firmware version 7.00 or higher, providing introductory information as well as detailed instructions on how to set up and manage the print server in various network environments. It is intended for everyone involved in installing and managing the print server. To fully benefit from this manual, you should be familiar with basic networking principles.

These instructions are based on the settings in a new and **unconfigured** print server. To reload the default parameters, you can perform a Factory Default, which will restore most of the settings. See *“Performing a Factory Default”* on page 129.

About Axis

Axis increases the value of network solutions. The company is an innovative market leader in network video and print servers. Axis' products and solutions are focused on applications such as security, surveillance, remote monitoring and document management. The products are based on in-house developed chip technology, which is also sold to third parties.

Axis was founded in 1984 and is listed on the Stockholmsbörsen (XSSE:AXIS). Axis operates globally with offices in 14 countries and in cooperation with distributors, system integrators and OEM partners in 70 countries. Markets outside Sweden account for more than 95 % of sales. Information about Axis can be found at www.axis.com

Support Services

Should you require any technical assistance, please contact your Axis reseller. If your questions cannot be answered immediately, your Axis reseller will forward your queries through the appropriate channels to ensure a rapid response.

If you are connected to the Internet, you can:

- Download user documentation and firmware updates
- Find answers to previously resolved problems in the FAQ database. Search by product, category or phrase
- Report problems to Axis support staff by logging in to your private support area
- Visit the Axis support Web at www.axis.com/techsup

Supported Environments

- Network Printing
- Windows
 - NetWare
 - Macintosh
 - UNIX/Linux

Section 2 Product Overview

Package Contents

Verify that nothing is missing from the AXIS 5500/AXIS 5550 package by using the check list below. Please contact your dealer if anything is missing or damaged. All packing materials are recyclable.

AXIS 5500 & AXIS 5550

<i>Hardware</i>	<i>Model</i>	<i>Part Number</i>
Network Print Server	AXIS 5500 (Japan)	0172-005-01
	AXIS 5500 (all other countries)	0172-001-01
	AXIS 5550 (Japan)	0173-005-01
	AXIS 5550 (all other countries)	0173-001-01
Adhesive Holder & Clip	ACC AXIS 5500 CLIPS KIT	20119
USB Cable*	70 cm, 28 inches	20208

	<i>Model</i>	<i>PS-H Part Number</i>
<i>Power Adapter</i>	Australia	19111
	Europe	19108
	Korea	19112
	UK	19109
	USA / Japan	19110

<i>Media</i>	<i>Title</i>	<i>Part Number</i>
CD	AXIS Network Product CD	22965
Warranty Sheet	Warranty Axis Servers (USA)	21681
	Warranty Axis Servers (other countries)	21680
Printed Material	AXIS 5500/AXIS 5550 Installation Guide	22908

<i>Optional accessories (not included in the box)</i>	<i>Description</i>	<i>Part Number</i>
Cables	Parallel Printer Cable	13360
	Centronics to Mini-Centronics Cable	16453

Ensure that the print server's Power Adapter is marked with the correct voltage! Refer to the tables above for details.

* The USB cable shipped with this product supports USB Low-Speed and Full-Speed. Hi-Speed is not supported.

AXIS Network Product CD

The AXIS Network Product CD provides an easy-to-use electronic catalog, that includes Axis software, firmware and user documentation. If your computer is set to French, German, Italian or Spanish, the information will automatically be presented in that language, otherwise you will see the English version.

To read the PDF documents you need an Acrobat Reader, which can be fetched at <http://www.adobe.com/products/acrobat/readermain.html>

- | | |
|--|--|
| Start-up Procedures for Windows | If your computer is configured to autostart CDs, the AXIS Network Product CD will start automatically when inserted into a local CD drive on Windows 98, Me, NT, 2000, XP and 2003 platforms. You can also navigate to the CD root directory and start the <i>index.htm</i> file from within the Windows file manager. |
| Start-up Procedures for UNIX/Linux, and Mac OS | Using your preferred file manager application, navigate to the CD root directory and click <i>index.htm</i> |
| Latest Versions | The latest version of Axis documentation, software and firmware is available on www.axis.com |

Physical Description

AXIS 5500

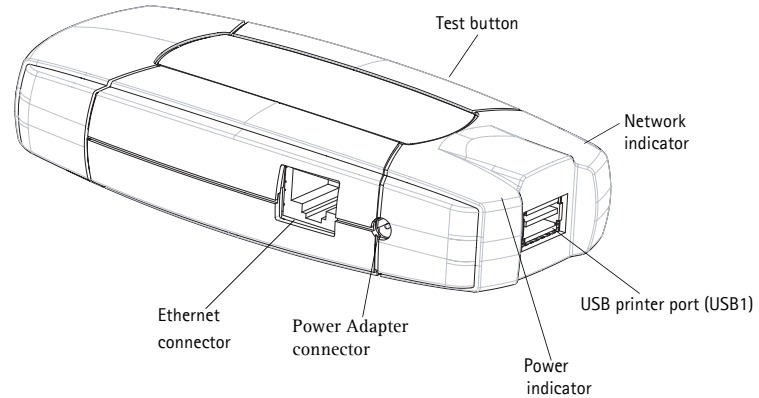

AXIS 5550

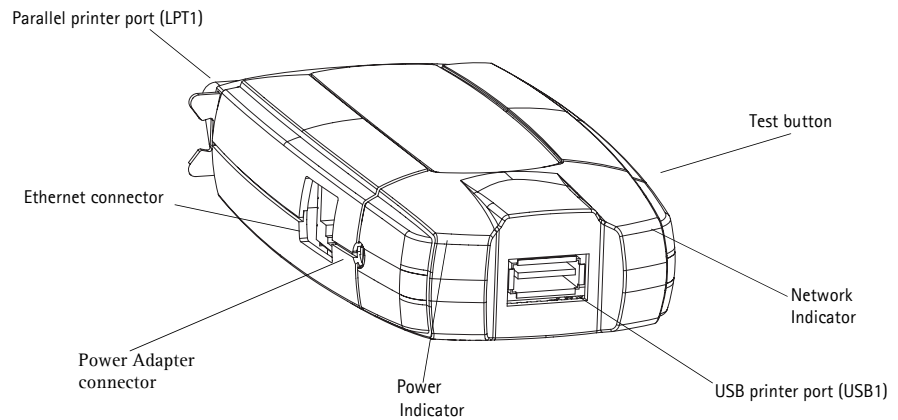

Network Connector Axis Network Print Servers are designed for 10 Mbps or 100 Mbps Ethernet networks and connect to the network via a twisted pair RJ45 category 5 cable (10baseT and 100baseTX) or better.

Printer Ports



- AXIS 5500
 - One Low- and Full-Speed USB 1.1 port, and works with USB v 2.0 (Low-Speed and Full-Speed). The USB cable shipped with the product supports Low-Speed and Full-Speed. **IMPORTANT!** Hi-Speed is not supported.
- AXIS 5550
 - One Low- and Full-Speed USB 1.1 port, and works with USB v 2.0 (Low-Speed and Full-Speed). The USB cable shipped with the product supports Low-Speed and Full-Speed. **IMPORTANT!** Hi-Speed is not supported.
 - One high-speed IEEE 1284 compatible parallel port.

Test Button	<p>The test button is used for:</p> <ul style="list-style-type: none"> • printing a test page to check the connection to the printer • printing the parameter list showing the print server settings • performing a Factory Default of the print server, which will restore most of the parameters and settings to factory default values <p>See “<i>The Test Button</i>” on page 129 for details.</p>
Network Indicator	The network indicator flashes to indicate network activity.
Power Indicator	The power indicator is lit while power is applied. If it is not lit, or if it flashes, there is a problem with the print server or its Power Adapter.
Compatible Printers	All printers can be used except host-based printers (also known as CAPT, GDI, PPA or Windows-based printers).

Mounting the AXIS 5500/AXIS 5550

Using the supplied clips, your AXIS 5500/AXIS 5550 can be mounted in many ways, e.g. on the back of the printer, on a wall. It can be placed behind the printer or next to a switch or a hub.

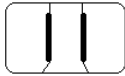
AXIS 5550 can also be inserted directly into the parallel port of the printer.

Adhesive Clip		Fasten to print server by peeling off adhesive tape.
Adhesive Holder		Fasten to mounting surface by peeling off adhesive tape.

Configuration and Management	The print server can be configured and managed from its internal Web pages, using HTTP as well as HTTPS in the secure mode. These Web pages offer you a platform independent management tool that is suitable for all supported network environments. See <i>Using a Web browser for Print Server Management</i> , on page 88 for details.
------------------------------	--

Features and Benefits

Reliability	The print server provides high performance and reliability combined with low power consumption. The electronic circuits are based on the AXIS ETRAX 100 LX chip, which comprises an integrated 32 bit RISC processor and associated network controllers.
-------------	--

- Flexibility** The print server supports printing in all major computer systems and environments, including five different print methods in the TCP/IP environment. AXIS 5550 allows you to print on two printers simultaneously.
- The integrated IPP (Internet Printing Protocol) function allows for printing from LAN to LAN via a WAN, such as the Internet.
- Speed** The AXIS ETRAX 100 LX chip has been specifically designed for LAN products.
- Easy to Install** The print server installs, operates and is managed in a reliable and easy fashion.
- Security** You can assign a password to restrict login and printer access. It is also possible to disable protocols and to configure a secure mode (https).
- Monitoring** The internal print server Web pages and AXIS ThinWizard (3.0 and up) allow you to continuously monitor printer status. The Web pages are used to monitor single Axis units while AXIS ThinWizard can be used to monitor multiple Axis units.
- Through e-mail notification, the printer administrator can be notified by e-mail whenever an event that requires human intervention occurs in a printer. The e-mail contains a short and concise description of the event.
- Future Proof** The firmware stored in the print server Flash memory can be upgraded over the network. This allows you to quickly update and enhance its operational features when new print server software becomes available.
- NetWare Packet Signature** The print server supports NetWare Packet Signature Level 1, 2, 3, which protects servers and clients using the NetWare Core Protocol services. NCP packet signature prevents packet forgery by requiring the server and the client to sign each NCP packet. See your Novell NetWare documentation for detailed information.

Section 3 Basic Installation

Quick Overview

Follow these steps to make your printer network ready:

1. "Connecting the Hardware" on page 13
2. "Assigning an IP Address to the Print Server" on page 15
3. "Making Network Printers available for printing on your PC" on page 21

Connecting the Hardware

AXIS 5500

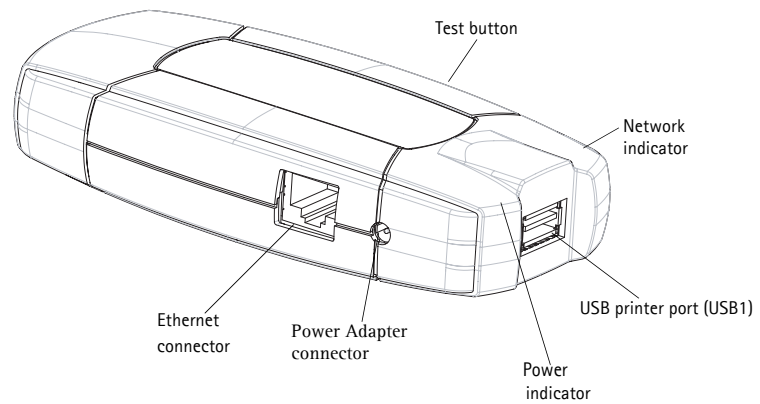

AXIS 5550

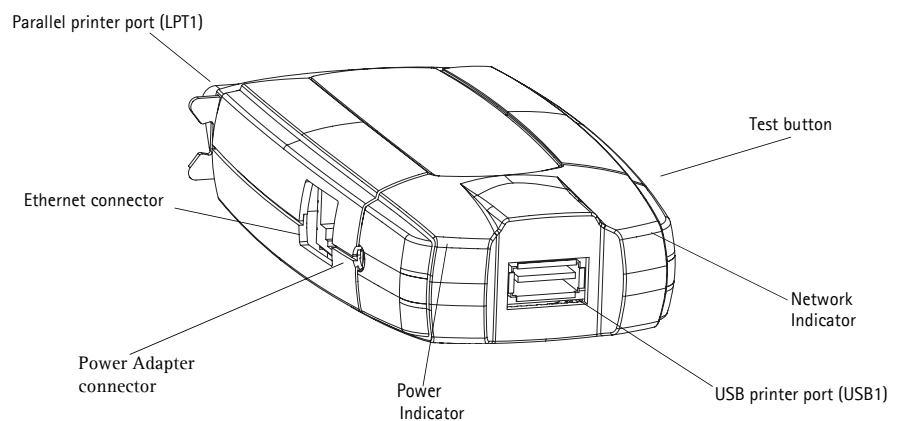

Backside label on print server

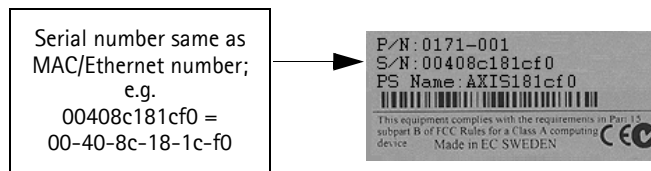

1. Make sure that your printer is switched off and that the print server's Power Adapter is disconnected.
2. Locate the **serial number**, found on the underside label of the print server, and write it down. You will need this number to configure the print server.
Example: S/N: 00408c181cf0
3. Connect the printer directly to a port on the print server or using an appropriate printer cable.
4. Connect the print server to the network using a twisted pair RJ45 category 5 cable, 10baseT or 100baseTX.
5. Switch on the printer and make sure it is ready for use.
6. Connect the Power Adapter to the print server. The power indicator will light up. When the network indicator starts to flash, the print server is correctly connected to the network.
7. Wait 1 minute. Press the test button on the print server once to print a test page. The test page includes a list of the most important parameters.

AXIS 5550 has two printer ports. If each port is connected to a printer, the test page will be sent to the parallel port by default.

Note:

AXIS 5550 uses high-speed Centronics Communication for the parallel port. For use with older printers not supporting high speed, this function can be disabled by using a standard Web browser. Log in to the print server's Web pages and choose Admin => General Settings => Change => LPT1 => Printer Port Speed.

Assigning an IP Address to the Print Server

Receiving an IP Address with DHCP

- If you have a DHCP server on your network, your print server will receive an IP address automatically. The IP address will then appear on the test page you print by pressing the test button once.
- If you are not working in a DHCP network, you need to set the IP address of the print server manually.

Notes:

- You need root privileges on your UNIX, Linux and Mac OS X system, or administrator privileges on a Windows NT server to set the IP address using RARP, BOOTP, DHCP and to add an entry to the ARP table with the command 'arp -s'.
- You need to know the Ethernet address of your AXIS 5500/AXIS 5550 in order to assign an IP address to it. The Ethernet address is based upon the serial number of your print server. This means, for example, that an AXIS 5500/AXIS 5550 with the serial number of 00408C100086, will have the corresponding Ethernet address of 00 40 8C 10 00 86. The serial number is located on the bottom label of the print server
- Unless you are assigning an IP address using DHCP or Auto-IP, you must obtain an unused IP address from your network administrator.

Important:

DO NOT use the IP addresses from the examples described here. Consult your network administrator before assigning an IP address to your print server.

Methods for Setting the IP Address

You can obtain an IP address for your AXIS 5500/AXIS 5550 by using one of the following methods, depending on your network operating environment.

See “*IP Addressing*” on page 125 for detailed instructions on IP address management.

Automatic IP Address Assignment

<i>Method</i>	<i>Server required</i>	<i>Comment</i>
AXIS AddPrinter Wizard	No server required	“Adding Printers in Windows 2000/XP/2003 using AXIS AddPrinter Wizard” on page 24
DHCP	DHCP server	Dynamic assignment of IP addresses. See “Set the IP Address with DHCP” on page 17
RARP	RARP server	Static assignment of IP addresses. Cannot be used over routers. See “Set the IP Address using RARP in UNIX/Linux” on page 18
BOOTP	BOOTP server	Static assignment of IP addresses. See “Set the IP Address using BOOTP in UNIX/Linux” on page 19
Auto-IP	No server required	Automatic assignment of IP addresses. See “Set the IP Address using Auto-IP” on page 19

Manual IP Address Assignment

Method	Platform	Comment	See
ARP/Ping	Windows	Requires the IP address for each device to be downloaded individually. Cannot be used over routers.	"Set the IP Address using ARP in Windows 98/NT/ Me/2000/XP" on page 20
	UNIX/Mac OS X	You must define the Default Router and Subnet Mask . Log in to the print server's Web pages and select Admin Network Settings Detailed View TCP/IP Network Default Router and Subnet Mask . DHCP, Auto-IP, BOOTP and RARP must first be set to No	"Set the IP Address using ARP in UNIX/Linux and Mac OS X" on page 20
AXIS AddPrinter Wizard	Windows 2000, XP, 2003	Axis software that allows you to find print servers in your network and assign an IP address to them.	"Adding Printers in Windows 2000 / XP / 2003 using AXIS AddPrinter Wizard" on page 24
AXIS ThinWizard	Windows 2000/XP	Axis software that assists in setting the IP address of multiple print servers simultaneously. This software is recommended for large organizations and enterprise networks.	"Using AXIS ThinWizard for Print Server Management" on page 92

Notes:

- The ability to set the IP address with ARP and PING will only be enabled the first 10 minutes after restarting the print server.
- Refer to "Setting Parameters" on page 44 for information about setting the IP address in the Macintosh environment.

Registering and Resolving Host Names

In order to register the host name of the AXIS 5500/AXIS 5550 in networks with dynamic IP address settings, WINS (Windows Internet Name Service) and DDNS (Dynamic Domain Name System) are supported. It is recommended that at least one of these methods should be used if you are setting the IP address of the print server using DHCP.

The host name of the AXIS 5500/AXIS 5550 is specified by the PS_NAME. parameter. Refer to the "The Parameter List" on page 137.

WINS Host Name Rules

WINS only supports 15 character long host names. If your host name is longer than 15 characters, the AXIS 5500/AXIS 5550 truncates the host name to 15 characters when registering with a WINS server. You can view the AXIS 5500/AXIS 5550 host name that is registered at a WINS server in the print server's Web interface. Refer to "Management and Configuration" on page 88.

DDNS Host Name Rules

DDNS supports 47 character long host names and can only consist of the characters 'A-Z', 'a-z', '0-9' and '-'. If your host name consists of any other characters, they are converted to '-' when registering with a DDNS server. You can view which host name that is registered at a DDNS server

in the print server's Web interface. Refer to "*Management and Configuration*" on page 88.

If the host name matches another entry in the DDNS data base, the print server deletes that entry before registering.

Notes:

- The default host name of the AXIS 5500/AXIS 5550 is 'AXIS' followed by the last 6 digits in the serial number. e.g. AXIS181636. The host name (Print server name) can be changed in the PS_NAME. field on the Admin | General Settings page.
- The host name limitations conclude that if you want to register the same host name at a WINS server and a DDNS server, the host name should be no longer than 15 characters and it should only contain the characters 'A-Z', 'a-z', '0-9' and '-'.
- Refer to your system manuals or to your network administrator for instructions on how host name resolutions are performed on your system.

Set the IP Address with DHCP

Follow the instructions below to download the IP address using DHCP:

1. Edit or create a scope in the DHCP manager of the DHCP daemon. The entries included in this scope should contain the following parameters:
 - range of IP addresses
 - subnet mask
 - default router IP address
 - WINS server IP address(es) or DDNS server IP address(es)
 - lease duration
2. Activate the scope. The print server automatically downloads the DHCP parameters. If you are using WINS or DNS, you should include at least one WINS or DNS server IP address in the DHCP scope. Immediately after the IP address has been received, the print server registers its host name and IP address on the WINS alternatively DNS server. Refer to "*Registering and Resolving Host Names*" on page 16 for more information. The print server can automatically download a customized *config* file from a TFTP server. Just add the name of the config file and the TFTP server's IP address to your DHCP scope. The *config* file is downloaded immediately after the print server receives its IP address.
3. You have now successfully set the IP address of your print server. Continue to "*Making Network Printers available for printing on your PC*" on page 21.

Note:

You have to restart the print server to download the IP address.

**Set the IP Address
using RARP in
UNIX/Linux**

Follow the instructions below to set the IP address using RARP.

Append the following line to your Ethernet Address table. This is typically located in the `/etc/ethers` file:

```
<Ethernet address> <host name>
```

Example:

```
00:40:8c:10:00:86 npsname
```

1. Update, if necessary, your host table and alias name databases as required by your system.
2. If it is not already running, start the RARP daemon. This is typically performed using the `rarpd -a` command.
3. Restart the print server to download the IP address.
4. You have now set the IP address of the print server. Continue to *"Making Network Printers available for printing on your PC"* on page 21.

Notes:

- If the host name has not been mapped to an IP address, simply replace the host name entry with the IP address in the example above.
- If you are using IBM AIX, you will probably not have access to a RARP daemon. If this is the case, you can use either ARP (see *"Set the IP Address using ARP in UNIX/Linux and Mac OS X"* on page 20) or BOOTP (see *"Set the IP Address using BOOTP in UNIX/Linux"* on page 19).
- You have to restart the print server to download the IP address.

**Set the IP Address
using BOOTP
in UNIX/Linux**

Below is an example of how to set the IP address of the print server using BOOTP:

Append the following entry to your boot table. This is typically performed by editing the file: `/etc/bootptab`

```
<host name>:ht=<hardware type>:vm=<vendor magic>:\
:ha=<hardware address>:ip=<IP address>:\
:sm=<subnet mask>:gw=<gateway field>
```

Example:

```
npsname:ht=ether:vm=rfc1048:\
:ha=00408c100086:ip=192.168.3.191:\
:sm=255.255.255.0:gw=192.168.1.1
```

1. If necessary, update your host table and alias name databases as required by your system.
2. If it is not already running, start the BOOTP daemon. This is typically performed using the `bootpd` command.
3. Restart the print server to download the IP address, default router address, and subnet mask. The print server can automatically download a customized *config* file from a TFTP server. Just add the name of the *config* file and the TFTP server's IP address to your boot table. The *config* file is downloaded immediately after the print server receives its IP address.
4. You have now successfully set the IP address of the print server. Proceed to "Making Network Printers available for printing on your PC" on page 21.

**Set the IP Address
using Auto-IP**

Auto-IP sets the IP address automatically in the absence of a DHCP server in Windows Me, 2000 and XP. If you have a DHCP server running on your network, the print server will receive an IP address immediately after you have connected it to the network. In the absence of a DHCP server, your print server will automatically be assigned an IP address through integrated Auto-IP. The Auto-IP address structure is: **169.254.xxx.xxx**.

The Auto-IP function will only work when DHCP is enabled in your print server. This function is enabled automatically upon installation of a brand new print server.

The easiest way to make sure DHCP and Auto-IP are enabled is to reset your print server (to Factory Default). See "The Test Button" on page 129 for instruction on how to do this.

If you perform a Factory Default on the print server and you do not have a DHCP server on your network, Auto-IP will automatically set the IP address of the print server. It is highly recommended that you change the Auto-IP address to a static IP address.

Set the IP Address using ARP in Windows 98/NT/Me/2000/XP

1. Open a Command Prompt and enter the following commands:

Syntax	Example
arp -s <IP address> <Ethernet address>	arp -s 192.168.3.191 00-40-8c-10-00-86
ping <IP address>	ping 192.168.3.191

2. The host will return **reply from 192.168.3.191**, or a similar message. This indicates that the address has been set and that communication is established.
3. Log in to the print server's Web pages (see *Using a Web browser for Print Server Management*, on page 88), select **Admin | Network Settings | Detailed View | TCP/IP Network** and define **Default Router** and **Subnet Mask**. Make sure you first set **DHCP, Auto-IP, BOOTP** and **RARP** to **No!**

You have now set the IP address of the print server. Continue to “*Making Network Printers available for printing on your PC*” on page 21.

Note:

- When you execute the ping command for the first time, you will experience a significantly longer response time than is usual.
- The ability to set the IP address with ARP and PING will only be enabled the first 10 minutes after restarting the print server.
- By using the `arp -d` command, the static entry in the arp table is removed from the host's cache memory.

Set the IP Address using ARP in UNIX/Linux and Mac OS X

1. Open a Terminal and enter the following commands:

Syntax	Example
arp -s <IP address> <Ethernet address>	arp -s 192.168.3.191 00:40:8c:10:00:86
ping <IP address>	ping 192.168.3.191

2. The host will return **psname is alive**, or a similar message. This indicates that the address has been set and that communication is established.
3. Log in to the print server's Web pages (see *Using a Web browser for Print Server Management*, on page 88), select **Admin | Network Settings | Detailed View | TCP/IP Network** and define **Default Router** and **Subnet Mask**. Make sure you first set **DHCP, Auto-IP, BOOTP** and **RARP** to **No!**

You have now successfully set the IP address of the print server. Continue to “*Making Network Printers available for printing on your PC*” on page 21.

Notes:

- If the host name has not been mapped to an IP address, simply replace the host name entry with the IP address.
- The ARP command varies between different UNIX/Linux systems. Some BSD type systems expect the host name and node address in reverse order. Furthermore IBM AIX systems will require the additional argument `ether`.
- When you execute the `ping` command for the first time, you may experience a significantly longer response time than is usual.
- The ability to set the IP address with ARP and PING will only be enabled the first 10 minutes after restarting the print server

Making Network Printers available for printing on your PC

Configuration Methods Once you have set the IP address of your print server, your network printer can be added to any PC on your network. The method that you choose should be dictated by your printing requirements and your supported network environments. Select the appropriate method from the table below: Installation Methods

<i>Operating system</i>	<i>Printing Protocol</i>	<i>See...</i>
Windows	TCP/IP	"Adding Printers in Windows" on page 23
	NetBIOS/NetBEUI	
NetWare	IP/IPX in PSERVER mode	"Setup using NDPS" on page 47
	IP/IPX in Remote Printer mode	"Setup using NDPS" on page 47
Macintosh	Mac OS X AppleTalk	"Adding Printers in Macintosh" on page 39
UNIX/Linux	TCP/IP	"Adding Printers in UNIX/Linux" on page 72

Installation and Integration

Refer to the table below to select the appropriate installation method. All Axis client software is available on www.axis.com

<i>Environment</i>	<i>Method/ Client Software</i>	<i>Description</i>
Windows 2000/XP/2003	AXIS AddPrinter Wizard	Used for adding network printers to your computer in Windows 2000, XP and 2003
Windows NT	Standard Windows Add Printer Wizard	Used for adding network printers to your computer in Windows 2000/XP/2003/NT
Windows 98, Me	AXIS Print Monitor software	Used for adding network printers to your computer in Windows 98/Me/NT
UNIX/Linux	KDE Printtool	Used for installing network printers in Debian and others
	Printconf	Used for installing network printers in Red Hat and others
	YaST2 Printer Configuration Tool	Used for installing network printers in SuSE
	Sam	Used for installing network printers in HP UX
	axinstall	Axis tool developed for installing network printers in UNIX/Linux
NetWare Pure IP	NetWare Administrator	Used for installing network printers in NetWare
NetWare	AXIS Gateway Configuration Utility software	Used for installing and configuring NDPS printers in NetWare
	AXIS NetPilot software	Tool that runs on Windows platforms that use NetWare over IPX.
Macintosh	Bonjour and Macintosh standard methods in native/classic mode	Used for installing network printers in Macintosh

See “*IPP (Internet Printing Protocol)*” on page 102 for information on Internet printing over Local and Wide Area Networks.

Section 4 Adding Printers in Windows

Overview of Installation Methods

This section describes how to add network printers to a computer in Windows. Refer to the table below to determine the most appropriate installation method according to your computer environment:

<i>Windows Platform</i>	<i>Protocol</i>	<i>Method</i>	<i>See...</i>
Windows 2000, XP, 2003	TCP/IP (LPR)	AXIS AddPrinter Wizard	"Adding Printers in Windows 2000/XP/2003 using AXIS AddPrinter Wizard" on page 24
		Windows Add Printer Wizard	"Adding Printers in Windows 2000/XP/2003 using Windows Add Printer Wizard" on page 26
		Microsoft LPR Monitor	"Adding Printers in Windows 2000/XP/2003 using the Microsoft LPR Monitor" on page 31
Windows 2000	NetBIOS/NetBEUI	AXIS Print Monitor software	Adding NetBIOS/NetBEUI Printers in Windows 2000 using AXIS Print Monitor, on page 34
Windows NT	TCP/IP	Windows Add Printer Wizard	"Adding Printers in Windows NT using the Microsoft LPR Monitor" on page 29
	NetBIOS/NetBEUI		"Adding Printers over NetBIOS/NetBEUI in Windows NT using AXIS Print Monitor" on page 35
Windows 98/Me	TCP/IP (LPR)	AXIS Print Monitor software	"Adding Printers in Windows 98 and Me over TCP/IP using AXIS Print Monitor" on page 36
	NetBIOS/NetBEUI		"Adding Printers in Windows 98 and Me over NetBIOS/NetBEUI using AXIS Print Monitor" on page 37

If you intend to use the print server in a multi-protocol environment, refer to the chapters pertaining to the respective operating systems in this manual.

Client/Server Network

For client/server printing, each computer sends print jobs through a network server computer.

The printer must first be installed on the server computer (from the Add Printer Wizard, AXIS Print Monitor) and then shared on the network, which makes it a network printer. It will then appear as a Network Printer (in Windows Add Printer Wizard and in AXIS Print Monitor) on the client computers. Each client computer must install the appropriate printer drivers in order to print properly.

For Windows 98 and Me, it is only necessary to install AXIS Print Monitor on a server for client/server printing.

Peer-to-Peer Network

In Peer-to-Peer networks, each computer prints directly to the network printer. The network printer appears as a Local Printer (in Windows Add Printer Wizard and in AXIS Print Monitor), and needs to be added to each

client computer that wants to print. Each client computer must install the appropriate printer drivers in order to print properly.

In Windows 98 and Me, AXIS Print Monitor must be installed on all (printing) client computers for Peer-to-Peer printing.

SNMP Device Index When using the TCP/IP protocol (and if the printer driver permits), the print server can use **SNMP Status** to find out if the printer is ready to accept a new job. See “*SNMP Device Index*” on page 158.

Adding Printers in Windows 2000 / XP / 2003 using AXIS AddPrinter Wizard

AXIS AddPrinter is a Wizard that locates your network printers and helps you install them in your Windows environment. When you have completed the Wizard, the network printer is ready for use. To install a network printer you must be logged in as an Administrator or be a member of the Administrators’ group.

1. Install AXIS AddPrinter Wizard on all Windows 2000, Windows XP and Windows Server 2003 workstations that will print via the print server.
2. Before you continue, ensure that the print server is properly connected to the printer, network and power.
3. Start AXIS AddPrinter. Click **Next**. The Wizard will perform an automatic search for all Axis network printers, which is indicated by the progress bar at the bottom of the screen.

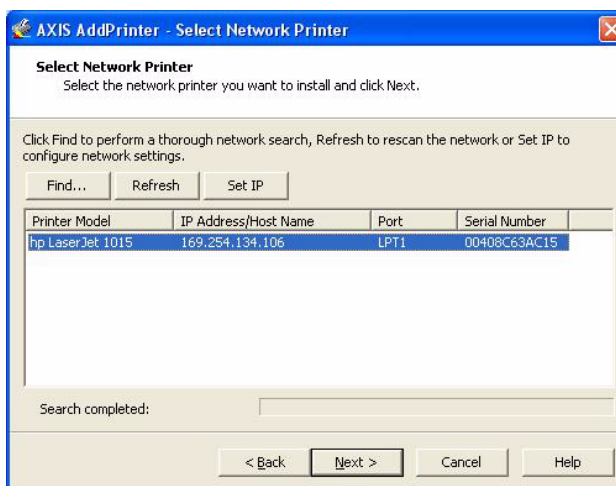

4. Select a printer from the **Select Network Printer** list and click **Next**. If the printer does not appear, see *Easy Access to All Network Printers*, below.

- The Wizard searches for a suitable printer driver.

If a suitable driver is not found, you will be asked to select a driver, otherwise the Wizard suggests which Printer Model and Printer Driver to use.

Click **Change driver** to select another driver, or click **Finish** to accept and install the suggested driver.

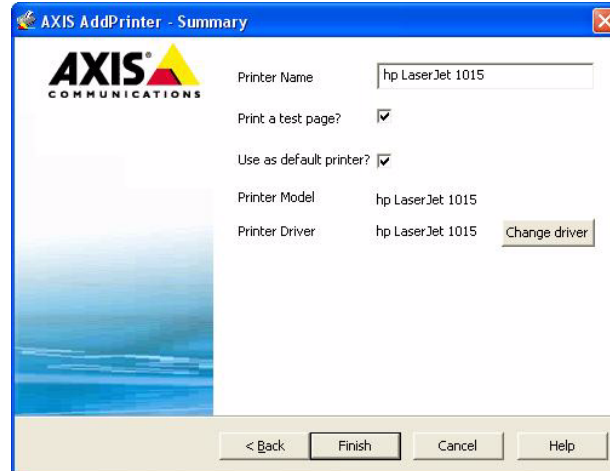

The installation is complete and you can start using the network printer.

Easy Access to All Network Printers

The Wizard's **Select Network Printer** list also provides quick and easy access to all connected and configured network printers.

Find... If the print server is located outside your local subnet it will not appear in the list. This may be the case if your router blocks SLP traffic. Click **Find**. Enter the IP address or host name displayed on the print server's Test page and click **OK**. *Example: 192.168.3.191 or AXIS181cf0*

Refresh If the print server has just been switched on, the printer has not had time to report its presence. This process can take a few minutes. In this case, **Printer Model** is stated as **No printer connected**. Click **Refresh** to rescan your local network segment for available print servers and update the status. If you still do not see the expected values, click **Help** and select **Troubleshooting**.

Set IP To set or change the IP address, select the print server and click **Set IP**. Decide whether you want to configure the IP settings manually or want the Wizard to suggest a static IP address.

Example: Select **Suggest...** and click **OK**. Confirm – or modify – the Wizard's suggested IP settings. Click **OK**.

Note: The **Suggest...** option is only available when the computer has one network card.

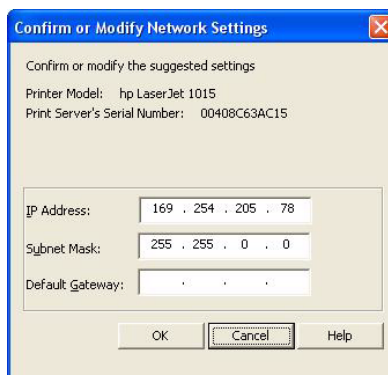

Go Straight to the
Print Server's Web
Interface

Right-click on a printer in the **Select Network Printer** list and select **Print server home page** to configure the print server from its embedded Web pages.

Adding Printers in Windows 2000 / XP / 2003 using Windows Add Printer Wizard

Follow the instructions below to use the standard Windows method for adding a network printer in Windows 2000/ Windows XP/Server 2003 (Windows XP Professional is described in this example):

Windows XP/Server 2003:

1. Go to **Start | Printers and Faxes** and click the Add a Printer icon to start the Add Printer Wizard. Click **Next**.

(Windows XP Home Edition: Choose **Start | Control Panel | Printers and Faxes | Add a Printer** to start the Windows Add Printer Wizard)

Windows 2000:

1. Go to **Start | Settings | Printers** and click the Add Printer icon to start the Add Printer Wizard. Click **Next**.
2. Select **Local Printer attached to this computer**. Make sure the **Automatically detect and install my Plug and Play printer** check box is not checked. Click **Next**.

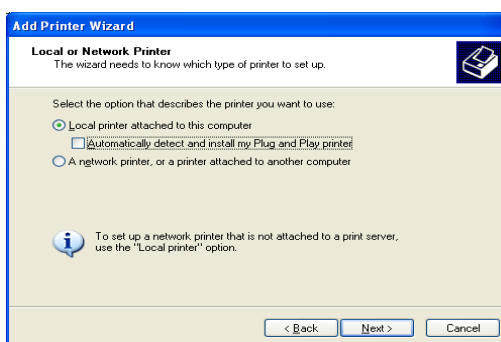

- Click the **Create a new port** radio button and select **Standard TCP/IP Port** from the list. Click **Next** and the **Add Standard TCP/IP Printer Port Wizard** starts. Click **Next**.

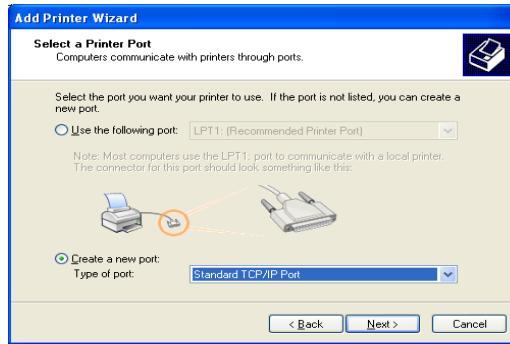

- Enter the IP address of the print server (*Example: 192.168.3.191*)
The **Port Name** will be filled in automatically when you enter the IP address.
Optionally, you can add the port you want to use as a suffix:

*AXIS 5500: Enter **_LPT1** for the USB port.*

*AXIS 5550: Enter **_LPT2** for the USB port and **_LPT1** for the parallel port.*

Click **Next**.

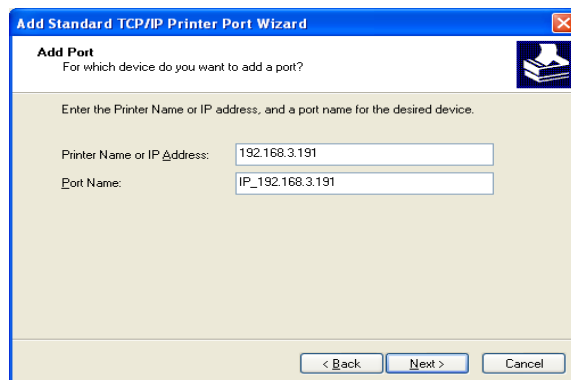

- In the **Additional Port Information Required** window, choose the **Device Port** you want to use, you will see LPT1, LPT2 and COM1 in a drop-down menu:

AXIS 5500: Enter LPT1 for the USB port*.

AXIS 5550: Enter LPT2 for the USB port* and LPT1 for the parallel port.

Click **Next**.

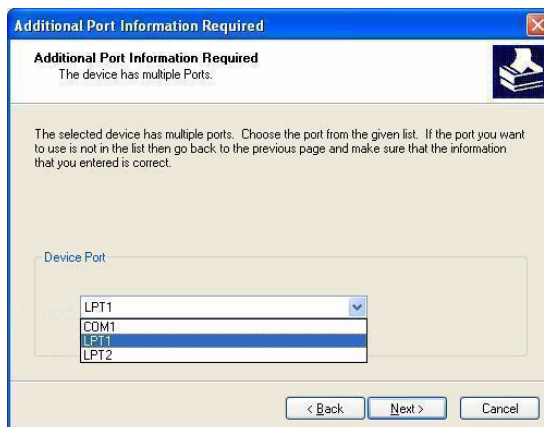

Click **Next** and **Finish**

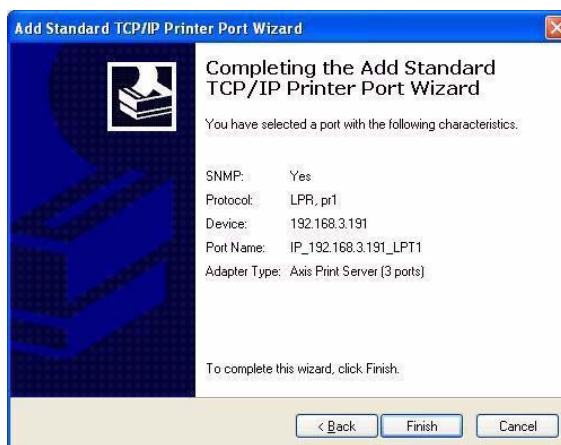

- Select **Manufacturer and Printer** from the driver list. Click **Next**.
- Choose whether you want to keep the existing driver or to replace it. If you already have the printer's driver installed, you will be asked whether to keep it or to replace it.
- Click **Next**. Supply a name for the printer and choose whether you want to make it your default printer. Click **Next**.



9. Choose whether you want to share the printer with other network users, print a test page, etc. Select the appropriate radio button and click **Next** and **Finish**.

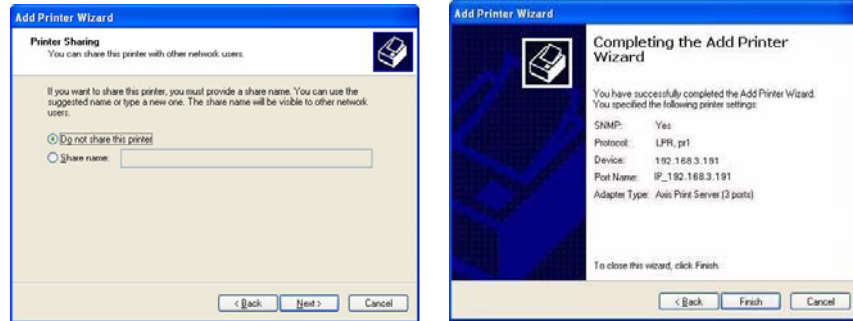

10. Print a test page to verify. You have now completed the installation.

*Tcpmon.ini

If you have an old version of Windows (prior to XP Service Pack 2), the USB port will not appear as an option in the Windows Device Port list (see Step 5 above). If so, install Axis tcpmon Upgrade Utility, a script that aids Windows in recognizing the USB port. This script upgrades the tcpmon.ini file (in the system32 directory) by adding new Axis print server ports in the Windows Available Ports list. The old tcpmon.ini file will be saved as tcpmon.ini_bak in the same directory, no other information will be affected. You have to be logged in as an Administrator to use this program. The program is available here: ftp.axis.com/pub_soft/prt_srv/utility/tcpmon

Adding Printers in Windows NT using the Microsoft LPR Monitor

If you have not already done so, you should perform the TCP/IP basic setup procedures prior to installing a printer for LPR printing.

Preparing for
LPR Printing

In the **Control Panel**, double-click the **Network** icon. Select the **Services** tab. If the TCP/IP Printing entry appears, then TCP/IP is already installed. Close the **Network** folder and go on to *Installing an LPR printer*, below.

First, prepare for LPR printing:

1. Open the **Control Panel** and double-click the **Network** icon.
2. Select **Protocols**.
3. Add **TCP\IP Protocol**.
4. Select **Services**.
5. Add **Microsoft TCP\IP Printing**.

- Installing a Network Printer
1. Go to **Start | Settings | Printers | Add Printer**. Select **My Computer** and click **Next**.
 2. From the **Available Ports** list, choose the appropriate printer port, which will appear as the IP address or host name of the print server. If it doesn't appear in the list, click **Add Port**.

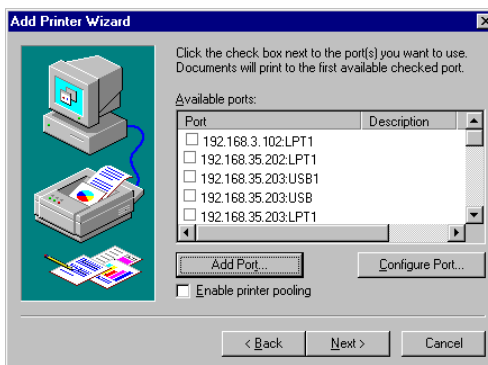

3. Choose **LPR Port** from **Available Printer Ports** and click **New Port**.

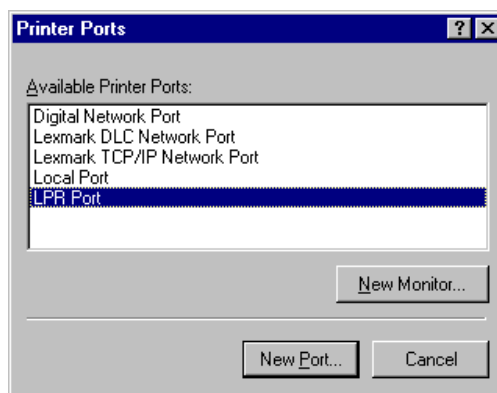

4. Type the print server's name or IP address in the field **Name or address of server providing lpr** (Example: 10.13.6.198). Then enter which port to use in the field **Name of printer or print queue on that server** according to the table below (Example: USB1). Click **OK** and then **Close**:

Ports available	USB port	Parallel port
AXIS 5500	USB1	—
AXIS 5550	USB1	LPT1

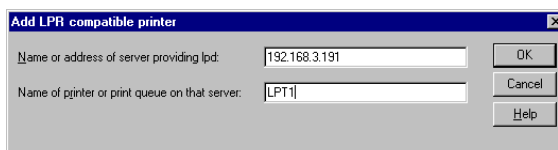

5. The added print server will now appear in the **Available Ports** list. Click **Next**, choose a driver and finish the installation as usual.

Adding Printers in Windows 2000 / XP / 2003 using the Microsoft LPR Monitor

This section describes how to set up a Windows 2000/XP server for LPR printing over the TCP/IP protocol, using the built-in Microsoft LPR Monitor i.e. **Print Services for UNIX**.

Note:

See "*Alternative Method for LPR Printing*" on page 32 for instructions on how to set up printing over LPR without installing **Print Services for Unix**.

- | | |
|----------------------------|---|
| Basic Setup | If you have not already done so, you should perform the TCP/IP basic setup procedures prior to installing a printer for LPR printing. |
| Preparing for LPR Printing | <p>Follow the following steps to prepare for LPR printing:</p> <ol style="list-style-type: none"> 1. Open the Control Panel. 2. Click Add/Remove Programs. 3. Click Add/Remove Windows Components. 4. Check Other Network File and Print Services and click Details. 5. Check Print Services for Unix and click OK. 6. Click Next and Finish. 7. Close Add/Remove Programs and the Control Panel. |
| Installing an LPR printer | Follow the instructions below to use the standard Windows method for installing an LPR printer in Windows 2000/XP: |
| Windows XP/Server 2003: | <ol style="list-style-type: none"> 1. Go to Start Printers and Faxes and click the Add a Printer icon to start the Add Printer Wizard. Click Next. |
| Windows 2000: | <ol style="list-style-type: none"> 1. Go to Start Settings Printers and click the Add Printer icon to start the Add Printer Wizard. Click Next. 2. Select the appropriate radio button: Local Printer. Click Next. 3. Click the Create a new port radio button and select LPR Port from the list. Click Next. |

4. Enter the name of the server (or its IP address) in the field **Name and address of server providing lpr** (Example: AXIS100086) and enter the port you want to use in the field **Name of printer or print queue on that server** (Example: USB1). Click **OK**.

Ports available	USB port	Parallel port
AXIS 5500	USB1	–
AXIS 5550	USB1	LPT1

End the wizard in the usual manner: select **Manufacturer and Printer**, keep/replace driver, name the printer, make it default or not, share it or not and finally decide whether you want to print a test page.

Client/Server Printing Select **Network printer** instead of **Local Printer** in Step 2 above if your print server has already been installed by the administrator on another computer. Follow the instructions in the **Add Printer Wizard** to complete the installation.

Important!

- Make sure that the **Automatically detect and install my Plug and Play printer** checkbox is not checked
- Press **F1** to access the Windows online help system if you need additional help when installing a printer/print server using this method.

Alternative Method for LPR Printing If you wish to print over LPR but do not wish to install **Print Services for Unix** you can do this by changing the printing protocol after having installed the printer using the Standard TCP/IP method, see “*Adding Printers in Windows 2000 / XP / 2003 using Windows Add Printer Wizard*” on page 26 for instructions.

Once the printer is installed, follow these instructions to change the printing protocol:

1. Go to **Start | Settings | Printers**.
2. Double-click the installed printer.
3. Select **Properties** from the **Printer** menu.
4. Click the **Ports** tab.
5. Click the **Configure Port** button.
6. Click the **LPR** radio button and enter the queue name (PR1, PR2...).
7. Click **OK** to finish.

AXIS Print Monitor Software

AXIS Print Monitor is the recommended tool to use for network printing in Windows 98 and Me environments. AXIS Print Monitor is available free of charge on www.axis.com

AXIS Print Monitor Overview	AXIS Print Monitor allows an AXIS 5500/AXIS 5550 to be connected in the same simple fashion as connecting a local printer. Once installed, it is automatically initialized upon system startup. AXIS Print Monitor has been developed for peer-to-peer printing, allowing your print jobs to be sent directly to the print server.
Printing Environments	AXIS Print Monitor supports printing over TCP/IP (LPR and Raw TCP) and NetBIOS/NetBEUI. To enable printing in these environments, please ensure that the desired printing protocols are running on your client.
Peer-to-Peer Printing	The AXIS Print Monitor needs to be installed on each workstation to perform peer-to-peer printing. Once installed, the AXIS Print Monitor allows you to access all network printers, just as if they were connected directly to your workstation.
Client/Server Printing	AXIS Print Monitor needs only to be installed on one server to perform client/server printing. The installed printers must be configured to be shared to allow clients to use them. Pop-up messages should not be enabled on the server as they will not be displayed on the client platforms.

Note:

AXIS Print Monitor can also be used for DOS printing. Please refer to the AXIS Print Monitor's Readme file for instructions. The Readme file is located in the same folder where AXIS Print Monitor is installed on your PC.
--

Adding NetBIOS/NetBEUI Printers in Windows 2000 using AXIS Print Monitor

See to it that the NetBEUI protocol is installed on your client. Follow the procedure below to install Axis Printer Ports from a Windows 2000 workstation:

1. To start the Add Printer Wizard, select **Settings | Printers** from the **Start** menu and double-click the **Add Printer** icon. Start the installation by clicking **Next**.
2. The Wizard asks you to select **Local printer** or **Network printer**. Select **Local printer**. Click **Next**.
3. Click **Create a new port**. In the Available Ports dialog, select **AXIS Port** and click **Next**.
4. Select **NetBIOS/NetBEUI** as your choice of network protocol and click **OK**.
5. Select the AXIS Port you want to add from the list of available ports. The port appears as <name>.<port> (Example: AX100086.LP1). The <port> is taken from the table below. Click **OK**.

Ports available	USB port	Parallel port
AXIS 5500	US1	—
AXIS 5550	US1	LP1

6. Choose the appropriate printer driver for your printer. Click **Next** and proceed directly to step 9. It is only necessary to perform steps 7 - 8 if your printer does not appear in the list.

Note:

Even if the desired printer is available in the **Manufacturers and Printers** lists, you are advised to use the printer driver provided with the printer. This assures you of the latest driver software.

7. Click the **Have Disk...** button. Insert the printer driver diskette/CD that was provided with your printer, select the appropriate diskette/CD drive and click **OK**.
8. Select the printer driver you want to install and click **Next**.
9. Enter an appropriate name for your printer and click **Next**.
10. Choose whether you want to share the printer with other network users and click **Next**.
11. Choose whether you want to print a test page, click **Next** and then **Finish**.

Adding Printers over NetBIOS/NetBEUI in Windows NT using AXIS Print Monitor

See to it that the NetBEUI protocol is installed on your client. Follow the procedure below to install Axis Printer Ports from a Windows NT workstation:

1. Install AXIS Print Monitor on all workstations that will print via the print server.
2. To start the Add Printer Wizard, select **Settings | Printers** from the Start menu and double-click the **Add Printer** icon.
3. The Wizard asks you to select **My Computer** or **Network printer server**. Select **My Computer**. Click **Next**.
4. Click **Add Port...** In the Available Ports dialog, select **AXIS Port** and click **New Port...**
5. Select **NetBIOS/NetBEUI** as your choice of network protocol and click **OK**.
6. Select the AXIS Port you want to add from the list of available ports. The port appears as <name>.<port> (Example: AX100086.LP1). The <port> is taken from the table below. Click **OK**. Close the Printer Ports window.

Ports available	USB port	Parallel port
AXIS 5500	US1	–
AXIS 5550	US1	LP1

7. Click the **Configure Port...** button. Choose whether error condition pop-up messages are to be displayed by checking the box in the Configure Axis Ports dialog. Define the frequency at which the error messages should be displayed after retry. Click **OK**. Continue the installation by clicking **Next**.
8. Choose the appropriate printer driver for your printer. Click **Next** and proceed directly to step 12. It is only necessary to perform steps 10-11 if your printer does not appear in the list.

Note:

Even if the desired printer is available in the **Manufacturers** and **Printers** lists, you are advised to use the printer driver provided with the printer. This assures you of the latest driver software.

9. Click the **Have Disk...** button. Insert the printer driver diskette/CD that was provided with your printer, select the appropriate diskette/CD drive and click **OK**.
10. Select the printer driver you want to install and click **Next**.
11. Enter an appropriate name for your printer and click **Next**.
12. Choose whether you want to share the printer with other network users and click **Next**.
13. Choose whether you want to print a test page and then click **Finish**.

Adding Printers in Windows 98 and Me over TCP/IP using AXIS Print Monitor

1. Install AXIS Print Monitor on all workstations that will print via the Axis print server.
2. Next, start the Windows Add Printer Wizard: select **Settings | Printers** from the **Start** menu and double-click the **Add Printer** icon.
3. After clicking **Next** in the first dialog, the Wizard asks you to select between **Local Printer** and **Network Printer**. You must select **Local Printer** as the print server emulates a local printer port. Click **Next**.
4. Choose the appropriate print driver for your printer. If the desired print driver already appears within the displayed **Manufacturers and printers** lists, highlight your selection, click **Next** and proceed directly to step 7. It is only necessary to perform steps 5- 6 if your printer does not feature in the model list.
5. Click the **Have Disk...** button. Insert the printer driver diskette/CD into the appropriate disk drive of your computer.
6. Select the type of printer you want to install from the diskette/CD and click **Next**. If you already have the printer's driver installed, you will be asked whether to keep it or to replace it.
7. Select the **Printers@TCP/IP Port** and click **Next**.
8. Enter an appropriate name for your printer and choose whether you want it to be the default printer. Click **Next**.
9. In the next window, do not order a Test Page to be written, just click **Finish**.
10. The printer you have defined will now be displayed in the Printers Folder. Right-click the printer object and select **Properties**.
11. Click the **Details** tab within the **Properties** page and then click **Add Port** to display the available monitors.
12. Click the radio button "other". Select **AXIS Port** and then click **OK**.
13. Select **LPR (TCP/IP)** as your choice of protocol and click **OK**.
14. Enter the IP address or the host name of your print server (Example: Enter an IP address: 192.168.3.191 or a host name: AXIS181636).
In the **Logical Printer Name** field, enter the port you wish to use: **USB1** or **LPT1**.
15. The TCP/IP port will then be added automatically to the list of available ports. Click **Apply** and **OK**.
16. You may now configure the port, as described below. The Axis Printer Port is now installed.

Configure the Port

1. Select **Settings | Printers** from the **Start** menu and highlight the printer you wish to configure. Select **File | Properties | Details** and click **Port Settings**.

2. Choose whether error condition pop-up messages are to be displayed by checking the box in the **Configure AXIS Ports** dialog. Define the frequency at which the error messages should be displayed after retry. Click **OK**.

Note:

Even if the desired printer is available in the Manufacturers and Printers lists, you are advised to use the print driver provided with the printer. This assures you of the latest driver software.

Adding Printers in Windows 98 and Me over NetBIOS/NetBEUI using AXIS Print Monitor

Follow the procedures below to install Axis NetBIOS/NetBEUI printer ports on a Windows 98 workstation, using AXIS Print Monitor:

1. To start the Add Printer Wizard, select **Settings | Printers** from the **Start** menu and double-click the **Add Printer** icon.
2. After clicking **Next** in the first dialog, the Wizard asks you to select Local printer or Network printer. Select **Local printer**. Click **Next**.
3. Choose the appropriate printer driver for your printer. If the desired printer driver appears in the displayed **Manufacturers and Printers** lists, highlight your selection, click **Next** and proceed directly to step 6. It is only necessary to perform steps 4 - 5 if your printer does not appear in the model list.

Note:

Even if the desired printer is available in the **Manufacturers and Printers** lists, you are advised to use the printer driver provided with the printer. This assures you of the latest driver software.

4. Click the **Have Disk...** button. Insert the printer driver diskette/CD that was provided with your printer, select the appropriate diskette/CD drive and click **OK**.
5. Select the printer driver you want to install and click **Next**.
6. Select the **AXIS Printer Port** from the Available Ports list. The port names appears as <name>.<port>. Here, <name> is AX followed by the last six digits of the print server's serial number (e.g. AX100086) and <port> is taken from the table below. Click the **Configure Port** button.

Port number	USB port	Parallel port
AXIS 5500	US1	–
AXIS 5550	US1	LP1

Example: AX100086.US1

7. Choose whether error condition pop-up messages are to be displayed by checking the box in the **Configure AXIS Ports** dialog. Define the frequency at which the error messages should be displayed after retry. Click **OK** and **Next**.
8. Enter an appropriate name for your printer and click **Next**.
9. Choose whether you wish to print a test page and click **Finish**.

Section 5 Adding Printers in Macintosh

Having connected the AXIS 5500/AXIS 5550 to your network, this section now describes how to set up your print server for printing in Mac OS X and earlier Macintosh environments using AppleTalk.

If you intend to use the print server in a multi-protocol environment, refer to the chapters pertaining to the respective operating systems in this manual.

Bonjour Printing in Mac OS X

Bonjour is available from Mac OS X 10.2 and up. Bonjour is enabled by default in the print server. You can alter the Bonjour parameters from the print server's Web interface: select **Admin | Network Settings | Detailed View | TCP/IP Network**.

1. From the Apple menu, select **Go | Applications | Utilities** and start the **Print Center** or the **Printer Setup Utility**.
2. Click **Add** in the Printer List.
3. From the drop-down list, select **Bonjour**.
4. High-light the printer you want to install. The print server's default name is **AXISxxxxxx Network Print Server** (where the xs represent the last six digits of the print server's serial number) followed by the ports available. *Example: AXIS610282 Network Print Server_USB1.*

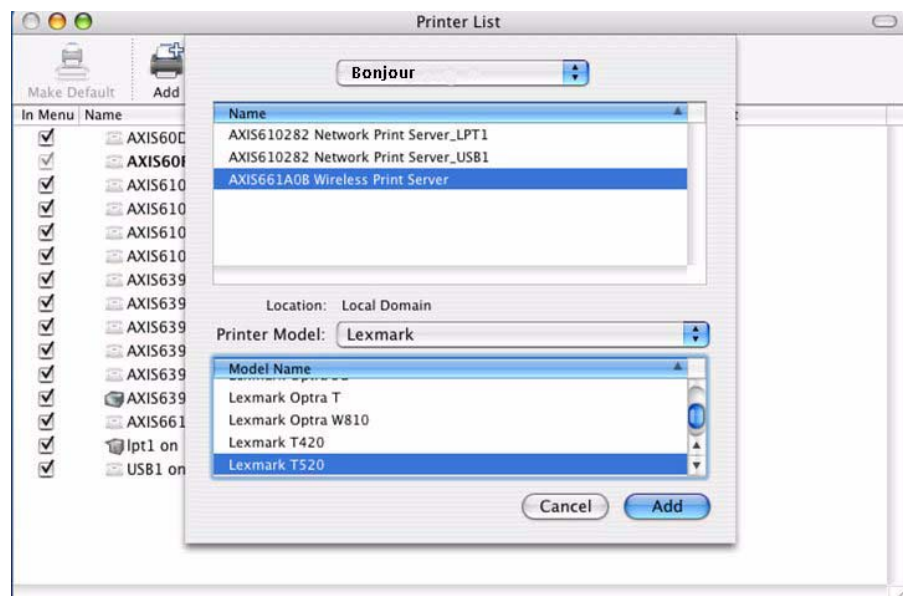

5. Select **printer manufacturer** and **model** from the drop-down list. (For some printer drivers, Printer Manufacturer and Model are selected automatically.)

- Click **Add** to finish the installation. The print server has now been added to the Printer List.

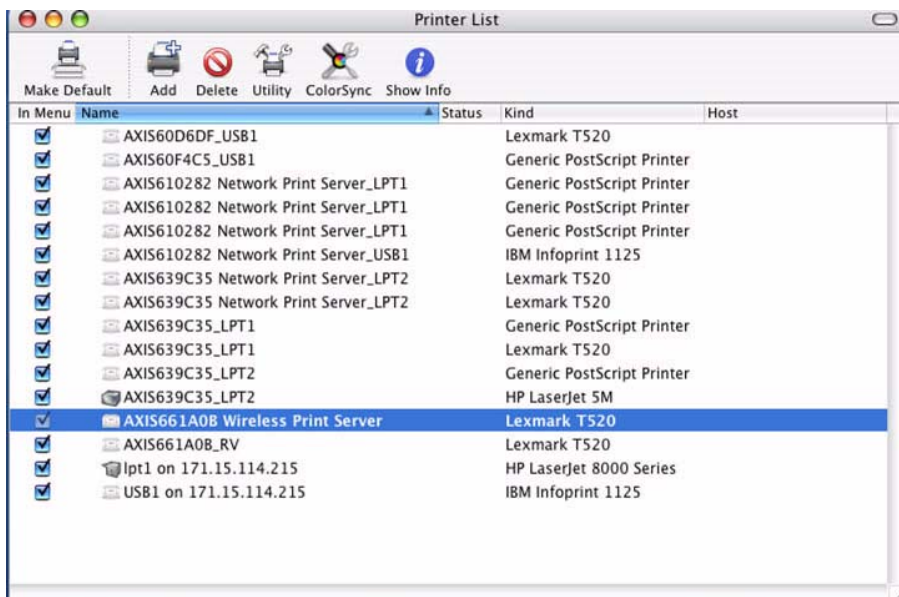

- If you wish to configure printer settings, click **Printers | Configure Printer**.

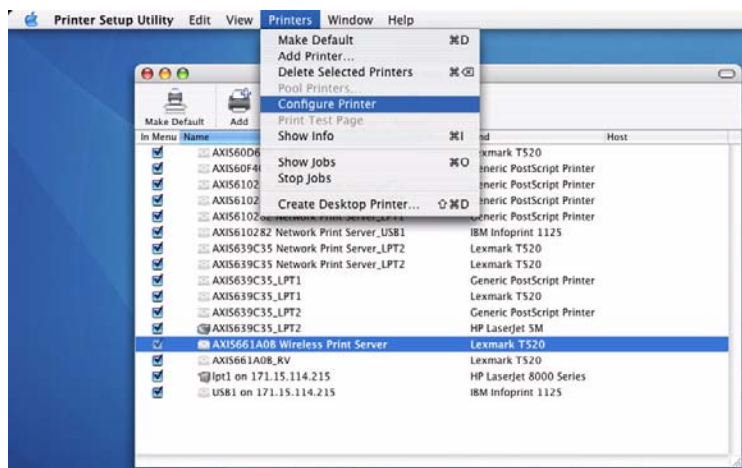

To Change the Bonjour Service Name

You can change the print server's Bonjour service name via the print server's Web interface: **Admin | Network Settings | Detailed View | TCP/IP Network => Bonjour Service Name.**

If the print server using Bonjour is already installed and the print server name or service name is changed, the print server must be removed from the Printer List and then re-installed with the new Bonjour service name.

Installation in Mac OS X using AppleTalk

This section describes setting up your print server for printing in the Mac OS X.

1. Start **Print Center** (from **Go | Applications | Utilities => Print Center**) or the **Printer Setup Utility**.
2. Select **Printers | Add Printer...**
3. From the **Printer List** dialog, select **AppleTalk**.
4. Now, the port of your AXIS 5500 will appear in the list of available printers. The port is shown as `<host name>_<port>`. **Example:** AXIS100086_USB1. On an AXIS 5550 you will also have access to an LPT port, which will appear as LPT1 in the list. **Example:** AXIS100086_LPT1.
5. Select the print server port you want to use.
6. Select an appropriate printer driver for your printer from the **Printer Model** drop-down list. If the printer is not available in the list, select **Generic**. (Note: **Generic** is only used for postscript printers.)

You can also browse for a printer driver on your computer or network by selecting **Other...** from the list.

7. Click **Add** to complete the installation.

Installation of LPR printing in MAC OS X

If you want to print using LPR, select:

1. **Printers | Add Printer...**
2. From the **Printer List** dialog, select **LPR printers using IP**.
3. Enter the IP address or host name of the print server in the **LPR printer's Address** field. You must uncheck the **Use Default Queue on Server** check box and enter a Queue Name:

Physical ports:

Enter **USB1** for AXIS 5500 and AXIS 5550 if you wish to use the USB port.

Enter **LPT1** for the AXIS 5550 if you wish to use the parallel port.

Logical printer ports:

AXIS 5550: pr1, pr3, pr5, pr7= LPT1. pr2, pr4, pr6, pr8=USB1

AXIS 5500: pr1-pr8= USB1

Choose a printer driver from the **Printer Model** list and click **Add** to finish.

Installation on Mac OS 9.1 or older, using AppleTalk

- Basic Configuration** On Mac OS 9.1 or older, basic configuration in AppleTalk is performed simply by opening the Chooser window and selecting a printer.
- You can change the default name of your print server or any of default parameters by editing the print server's *config* file. To access the *config* file from a Macintosh, you can use:
- any Web browser with Javascript enabled
 - FTP using MacTCP, Fetch or Anarchie
- In order to use any of these methods, you must assign an IP address to the print server as described in "Setting Parameters" on page 44.

Choosing a Printer

- Selecting a Printer** The method for choosing a printer varies depending on which version of LaserWriter printer driver you are using.

- The LaserWriter 7.0 driver assumes that you use a standard PostScript driver, and cannot take advantage of any printer specific features.
- The LaserWriter 8.0 driver uses PPD files that contain printer descriptions. This gives you full control over any features your printer might have.

- Autodetect Printer Type** The print server can automatically detect the type of printer you are using if you enable **Autodetect Printer Type**. The print server can then recognize Epson and Hewlett Packard InkJet printers. Most Epson and Hewlett Packard InkJet printers that have Mac OS printer drivers for network printing are supported. Without the Autodetect Printer Type function, the AppleTalk printer type has to be specified manually in the print server. For Epson InkJets it would be "EPSONLQ2" and for HP InkJets it would be "DeskWriter". If the print server does not recognize the connected printer, the default setting "LaserWriter" will be used as printer type. "LaserWriter" is the recommended setting to be used with all PostScript printers.

To enable **Autodetect Printer Type**, log in to your print server's Web interface and select **Admin | Network Settings | Detailed View | Macintosh | Auto Detect Printer Type | Yes**.

See the **Help** pages in the print server's Web interface for details.

- LaserWriter 7.0 Printer Driver** Follow the instructions below to choose a printer:
1. Select **Chooser** from the **Apple** menu.
 2. Click the **LaserWriter** icon.
 3. If your network has more than one zone, click on the zone you want. (If your network does not have any zones, this box will not appear.)

4. Click the name of the printer you want – the ports are shown as <host name>_<port>. **Example:** AXIS100086_USB1.
On an AXIS 5550 you will also have access to an LPT port, which will appear as LPT1 in the list. **Example:** AXIS100086_LPT1.
5. Click the **Close** box. This completes the configuration and closes the Chooser.

Repeat this procedure for each Macintosh computer on the network using the print server.

LaserWriter 8.0 Printer Driver

Follow the instructions below to choose a printer:

1. Select **Chooser** from the **Apple** menu.
2. Click the **LaserWriter 8.0** icon.
3. If your network has more than one zone click on the zone you want. (If your network does not have any zones, this box will not appear.)
4. Click the name of the printer you want – the ports are shown as <host name>_<port>. **Example:** AXIS100086_USB1.
On an AXIS 5550 you will also have access to an LPT port, which will appear as LPT1 in the list. **Example:** AXIS100086_LPT1.
5. Click **Setup...** and then **Auto Setup**. If the selected printer supports bi-directional printing and the appropriate PPD file is available, the installation is performed automatically and you can therefore proceed directly to step 7 (if this is not the case, the PPD file must be selected manually, as described in step 6).
6. Choose the PPD file matching your printer, and click **OK**.
If your printer does not appear in the PPD file list, please contact your printer vendor. Use the Generic PPD if you do not need any printer specific features.
7. Click **OK**, and then click the **Close** box. This completes the configuration and closes the Chooser.

Repeat this procedure for each Macintosh computer on the network using the print server.

Bi-directional Support

The AXIS 5500/AXIS 5550 allows the printer driver to communicate directly with the printer and consequently facilitates complete functional control over print jobs, e.g. automatic downloading of fonts not resident in the printer.

This functionality has backward compatibility with older printers and Macintosh computers, which means that the AXIS 5500/AXIS 5550 can generate appropriate responses to Macintosh printer queries when the connected printer does not support bi-directional communication.

Verifying the Setup

You simply need to print a document from the Macintosh computer to verify communication to the chosen printer. The basic installation can be considered complete if the print test is satisfactory. The AXIS 5500/AXIS 5550 is now ready for use.

Note:

For information on advanced AppleTalk functions such as non-PostScript printer support, please refer to the AXIS 5500/AXIS 5550 Technical Reference on the Axis Web site.

BCP and TBCP You should specify if you want to enable or disable binary transfer of print data in the print server's Web interface (**Admin | Network Settings | Detailed View | Macintosh | Binary Protocol for Printer *n***). By enabling binary transfer you reduce printing time, provided that the print job is sent as binary data to the print server. This is particular true when you are printing large bitmaps.

- TBCP enables the print server to use the TBCP (Tagged Binary Communication Protocol) to transfer print data to the printer. Select this alternative when using Postscript printers.
- BCP enables the print server to use the BCP (Binary Communications Protocol) to transfer print data to the printer. Select this alternative when using Postscript printers.
- None disables all binary transfers, select this alternative for all non-PostScript printers and for ASCII PostScript printing.

Notes:

- If you have have set the Autodetect Printer Type parameter to YES, the text output format will be chosen automatically (Admin | Network Settings | Detailed View | Macintosh | Auto Detect Printer *n* Type | Yes).
- Some printers, e.g. Epson InkJet printers, can not be used when TBCP is enabled.

Setting Parameters In AppleTalk, you can change a limited number of the parameters of the AXIS 5500/AXIS 5550. You can:

- enable and disable binary data transfers for your printing
- select the type of binary transfer protocol to use
- specify the AppleTalk printer type
- set the IP address

However, by assigning an IP address to your print server, you have access to all of the print server parameters via any standard Web browser or via FTP. Refer to *Section 10 Management and Configuration*, on page 88 for more information.

Example: The following example describes how you set the print server parameters in AppleTalk.

Important:

DO NOT use the parameter values from this example when configuring your print server. You should select values that are appropriate for your printers and network settings.

1. Open the **Chooser** from the Apple menu.
2. Select a network printer driver – any LaserWriter will do.
3. Select the printer port ending with **_CFG**.
4. Close the Chooser.
5. Open a text editor, e.g. SimpleText.
6. Write a text file containing the parameters you want to set:

```
BINARY_TYPE_1.      :BCP
INT_ADDR.            :192.168.3.191
ATYPE_1.             :EPSONLQ2
```

Note:

Parameters that you do not want to set should be excluded from the text file. Refer to the Parameter list in this manual for information about which values that are valid for each parameter.

7. Print the text file. The settings will be stored in the print server.
8. Open the Chooser and select the printer port you wish to use for printing documents.
9. Close the Chooser.

Note:

The **_CFG** port disappears 60 minutes after the AXIS 5500/AXIS 5550 has been powered on. If you want it to reappear, you must restart your print server.

Section 6 Adding Printers in NetWare

This section describes how to continue the installation of the AXIS 5500/AXIS 5550 in the NetWare environment. Identify which transport protocol you are running on your network and which installation method you should use. Continue the installation by selecting the appropriate installing instructions from the table below:



<i>Installation method</i>	<i>Transport protocol</i>	<i>Action</i>
NDPS	TCP/IP IPX/SPX	See "Setup using NDPS" on page 47, "Public Access Printers" on page 47 and "Controlled Access Printers" on page 51
iPrint	iPrint over LPR	See "Setup using iPrint" on page 61 and "Install a printer using AXIS LPR Gateway Configuration Snap-in" on page 63
	iPrint over IPP	See "Setup using iPrint" on page 61 and "Install a printer with AXIS IPP Gateway Configuration Snap-in" on page 63
Queue-based printing	IPX/SPX Basic Configuration	To install using the AXIS NetPilot Installation Wizard, see "Basic Setup with AXIS NetPilot" on page 65.
	IPX/SPX Advanced configuration	If you need a more advanced installation that is not covered by the AXIS NetPilot Installation Wizard, see "Advanced Installation using AXIS NetPilot" on page 67.

See "NetWare Administration" on page 71 for information on Novell's administration tools.

If you intend to operate your AXIS 5500/AXIS 5550 in a multi-protocol, mixed environment, you should also proceed to the other relevant sections in this manual.

Setup using NDPS

The AXIS 5500/AXIS 5550 supports Novell Distributed Print Services (NDPS). You can run NDPS over Pure IP (TCP/IP) or IPX/SPX.

Before the AXIS 5500/AXIS 5550 can be installed, make sure that NDPS is installed and a Broker is loaded on your NetWare file server.

Axis Network Print Server uses the AXIS NDPS Gateway for printing in networks using either IP or IPX as transport protocols. The printer gateways are included with the NDPS software (from version 5.1 and up) and are automatically installed together with NDPS.

Installing the Axis Network Print Server in the NDPS environments

Having assigned an IP address to the AXIS 5500/AXIS 5550 as described in *Assigning an IP Address to the Print Server*, on page 15, you are now ready to install the Axis Network Print Server for NDPS printing. You can select to install the connected printers as public or controlled access printers. Follow the instructions below to install the Axis Network Print Server using NDPS:

Important:

- The NDPS Enabled parameter of the Axis Network Print Server is by default enabled. It must be set to Yes in order for the communication between the print server and the NDPS gateway to be enabled. To change this parameter, log in to the print server's Web pages and choose: Admin | Network Settings | Detailed View | NetWare=> NDPS Enabled => Yes.
- If you do not have an NDPS Manager object available, start out with creating one in the NetWare Administrator.

Public Access Printers

Follow these instructions to create a public access printer using the NDPS Manager object in your NetWare administrator utility:

1. Double-click on the NDPS Manager object you will be using to control the Printer Agents.
2. On the **Identification** page for the NDPS Manager, click the printer **Agent List** button. The **Printer Agent List** dialog will appear.
3. Click **New**. The **Create Printer Agent** dialog will appear.

4. Type a name of your choice in the NDPS Printer Agent field

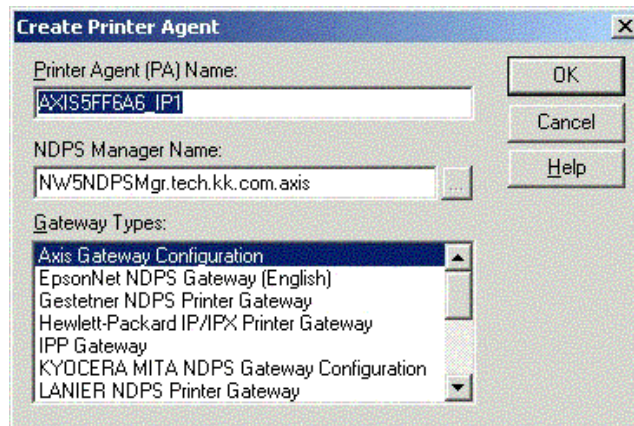

5. Select the Axis Gateway configuration in the Gateway Type window.
6. Click OK
7. In the Select the printer's type window, choose your printer. If you cannot find the printer, select an appropriate Generic one (PCL, PS, etc)

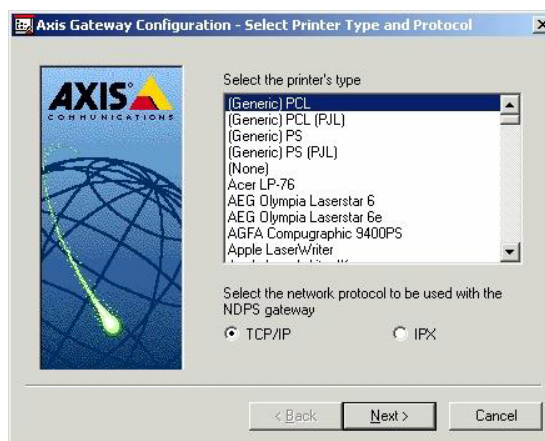

8. Select TCP/IP (default) or IPX as network protocol. Click Next.

9. You will find the print server in the next window with the printer attached on the connected port. Depending on the transport protocol you used when you start the installation, the print server should appear as following:

- TCP/IP Network protocol:

IP Address and Port, e.g: *192.168.70.243* and *LPT1*

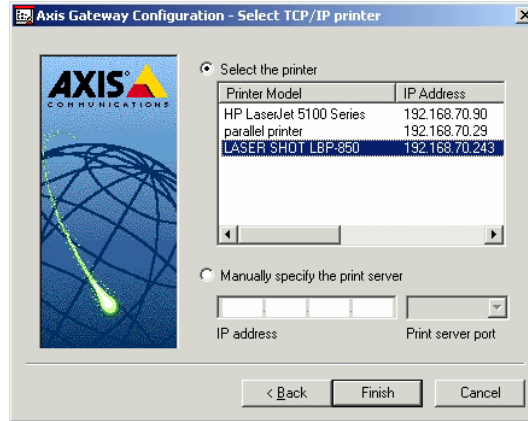

Only the ports with a connected printer show up in this window. If the printer is not in the displayed print list, click **Manually specify the print server** and do the following: Enter the print server's IP address in the **IP Address** field and choose a port in the **Print Server Port** field:

e.g., 192.168.70.243 and LPT1

The port numbers are USB1 or LPT1; "other/unknown" denotes the USB1 port.

Ports available	USB port	Parallel port
AXIS 5500	other/unknown	—
AXIS 5550	other/unknown	parallel

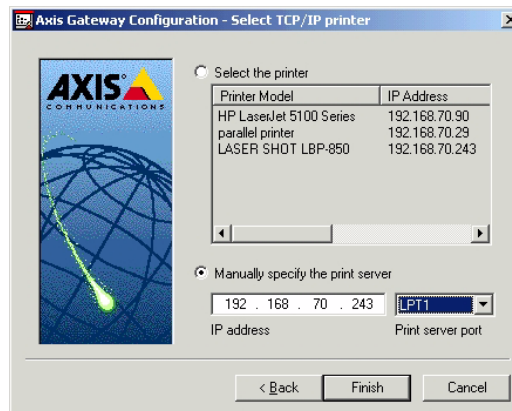

IPX Network protocol:

All the available ports will be presented, regardless if the printers are or not connected to those ports, e.g.

AXIS5FF66A_P1 corresponds to the LPT1 port, and
 AXIS5FF66A_P2 corresponds to the USB1 port.

The IPX Addresses for the above printers will appear as:

<IPX External Network Number>:<Print server's HW address>:<Socket Number>

Example: 01d7e1c2:00408c5ff6a6:400c, where 400c corresponds to the LPT1 physical port, and 401c corresponds to the USB1 physical port.

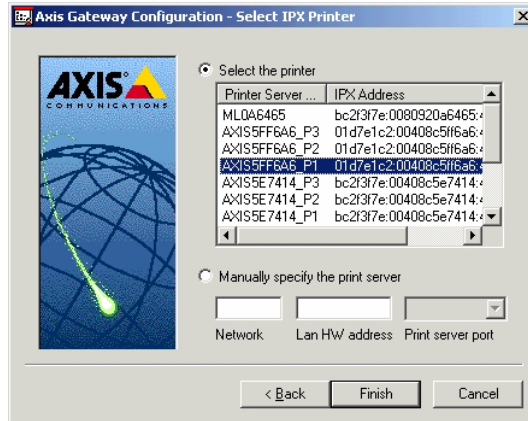

If the printer is not in the displayed print list, click **Manually specify the print server** and do the following:

1. Enter the <IPX External Network Number> in the **Network** field.
2. Enter the <Print server's HW address> in the **LAN HW address** field.
3. Choose a port in the **Print server port** field, e.g. 01d7e1c2:00408c5ff6a6 and LPT1

The port numbers are USB1 or LPT1; “other/unknown” denotes the USB1 port.

Ports available	USB port	Parallel port
AXIS 5500	other/unknown	–
AXIS 5550	other/unknown	parallel

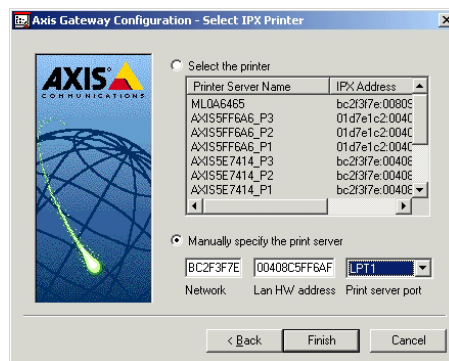

4. When done, select your printer and click **Finish**.

- Next, select the printer drivers for each client operating system. (Windows 2000, NT and 95/98). These drivers will be automatically downloaded to users' workstations when they install this printer in the future.

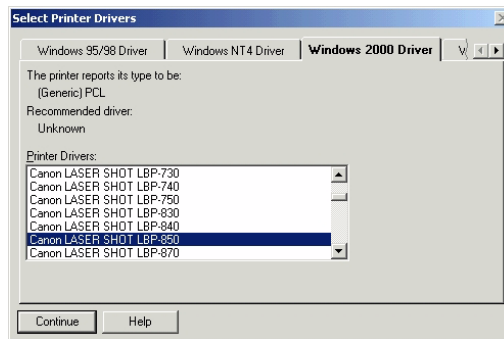

- Click **Continue** and **OK** in the next NDPS window. The new Printer Agent appears in the Printer Agent List window.

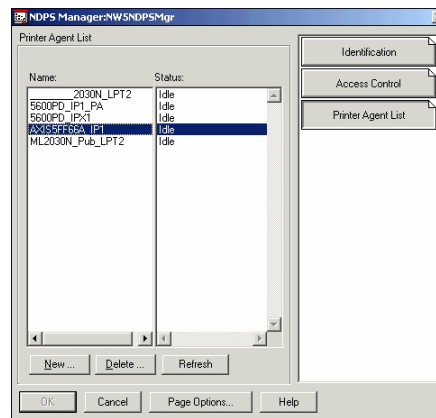

Check the Status: it should be **Idle**.

- Press **Cancel** to close the NDPS Manager

To install the printer on the workstation, See "Installing an NDPS Printer on a Workstation" on page 57.

Controlled Access Printers Follow these steps to create a controlled access printer as an object in the Directory Tree, using the NetWare administrator utility:

- Log in as Admin.
- Start the NW Admin utility on any Workstation (SYS:PUBLIC\WIN32\nwadmin32.exe).
- Browse the context your NDPS Manager resides in.

- From the **Object** menu, select **Create**. The New Object dialog appears.

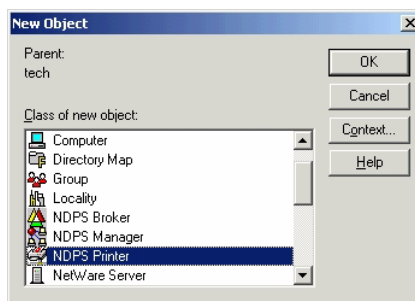

- Select **NDPS Printer**. The Create NDPS Printer dialog appears.

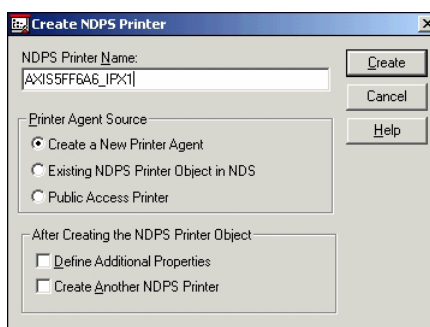

- Type a name of your choice in the NDPS Printer Name field, e.g. **AXIS5FF66A_IPX1**
In the Printer Agent Source field, select the source of the Printer Agent. The following options are available:
 - **Create a New Printer Agent.** If you select this option, you are asked to select either the Novell Gateway or a third party Gateway.
 - **Printer Agent on Existing NDS Object.** Use a Printer already configured as a controlled access printer (NDPS Printer Object).
If you select this option, a list of current NDPS Printer Objects in this container will be displayed from which you can select the one you want to use.
 - **Public Access Printer Agent.** Use an existing Printer Agent representing a Public Access Printer.
- Select **Create a New Printer Agent** and click **Create** to display the Create Printer Agent dialog.

8. Confirm the Printer Agent name (default is the name of the new printer you are creating) and browse to select the NDPS Manager to which you want to assign it

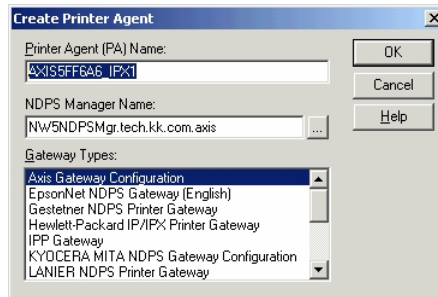

9. Select AXIS Gateway Configuration in the Gateway Type field.
10. Click OK.
11. In the **Select the printer's type** window choose your printer. If you cannot find the printer, select an appropriate Generic one (PCL, PS, etc)

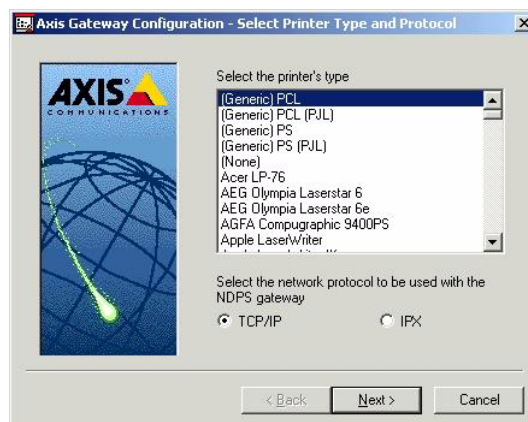

12. Select TCP/IP (default) or IPX as network protocol.
13. Click Next.
14. You will find the print server in the next window with the printer attached on the connected port.
Depending on the transport protocol you used when you start the installation, the print server will appear as:

- TCP/IP Network protocol:
IP Address and Port, e.g: *192.168.70.243* and *LPT1*

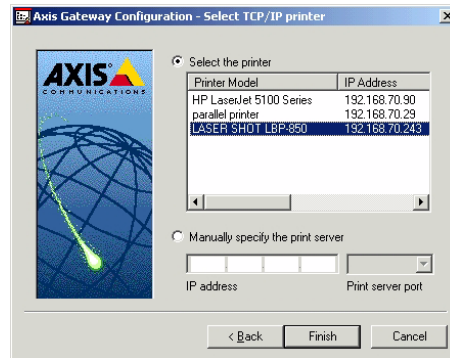

Only the ports with a connected printer will show up in this window.
If the printer is not in the displayed print list:

1. Click **Manually specify the print server** enter the print server's IP address in the **IP Address** field and choose a port in the **Print server port** field e.g., *192.168.70.243* and *LPT1*.

The port numbers are USB1 or LPT1; "other/unknown" denotes the USB1 port.

Ports available	USB port	Parallel port
AXIS 5500	other/unknown	—
AXIS 5550	other/unknown	parallel

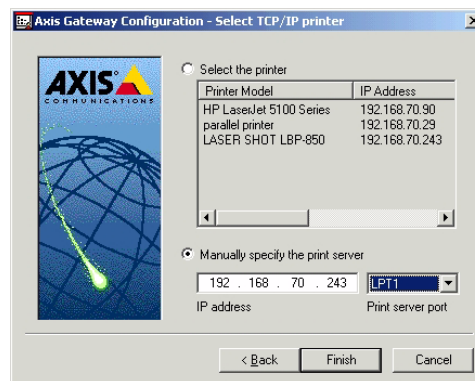

IPX Network protocol:

All the available ports will be presented, regardless if the printers are or not connected to those ports.

Example: **AXIS5FF66A_P1** corresponds to the **LPT1** port, and **AXIS5FF66A_P2** corresponds to the **USB1** port.

The IPX Addresses for the above printers will appear as:
 <IPX External Network Number>:<Print server's HW address>:<Socket Number>

Example: **01d7e1c2:00408c5ff6a6:400c**, where 400c corresponds to the LPT1 physical port, and 401c corresponds to the USB1 physical port.

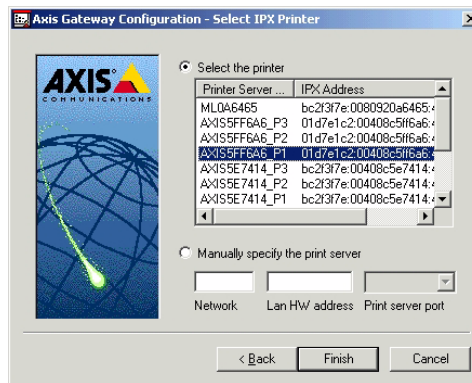

If the printer is not in the displayed print list:

1. Click **Manually specify the print server** and enter the <IPX External Network Number> in the **Network** field.
2. Enter the <Print server's HW address> in the **LAN HW address** field and choose a port in the **Print server port** field:
e.g.: 01d7e1c2:00408c5ff6a6 and LPT1.

The port numbers are USB1 or LPT1; "other/unknown" denotes the USB1 port.

Ports available	USB port	Parallel port
AXIS 5500	other/unknown	–
AXIS 5550	other/unknown	parallel

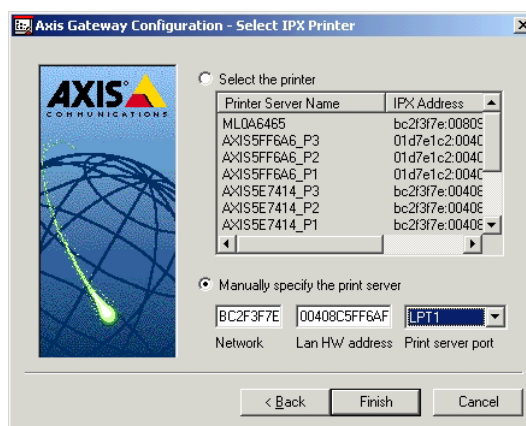

3. When done, select your printer and click **Finish**.
4. Next, select the printer drivers for each client operating system (Windows 2000, NT and 95/98). These drivers will be automatically downloaded to users' workstations when they install this printer in the future.

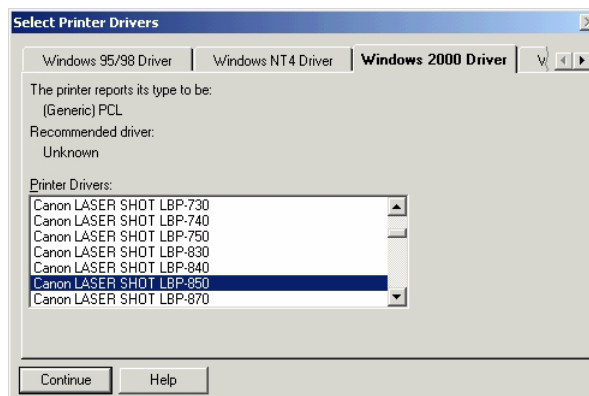

- Click **Continue** and **OK** in the next NDPS window. Your printer will appear as an NDS object in the Directory Tree and will offer a full range of network security options.



To install the printer on the workstation, See “Installing an NDPS Printer on a Workstation” on page 57.

Installing an NDPS Printer on a Workstation

To install the printer on a workstation, use either Novell Printer Manager (NetWare 5.1 only) or the Add Printer Wizard on the local workstation.

Using Novell Printer Manager

- Log in as Admin.
- On the any workstation, browse to <NW 5.1 File Server>\SYS:PUBLIC\Win32 and start Nwpmw32.exe (Novell Printer Manager). The Novell Printers dialog appears, displaying a list of installed Public or Controlled printers (if any printers have previously been installed on the workstation).

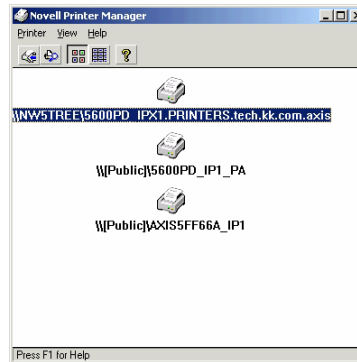

- From the Printer Manager’s Printer pull down menu, select **New**.

- Click **Add**. A list of available printers appears.

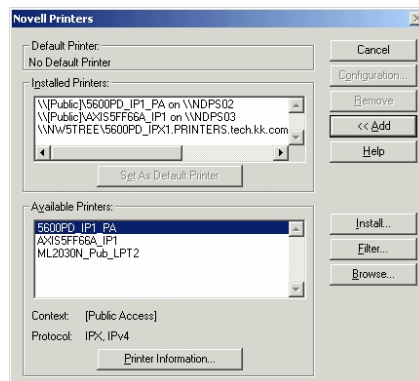

- The list of available printers shows the NDPS Public Access Printers on the network and the NDPS Controlled Access Printers in your current NDS context. To see the Controlled Access Printers in other context that you have rights to, click the **Browse** button and select your choice. Click **OK**.

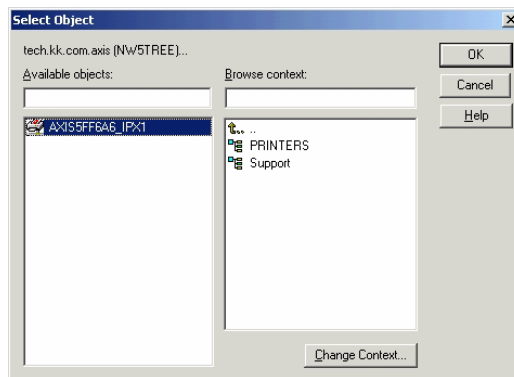

- Once selected, click **Install**. The Novell Printers – Install dialog appears.

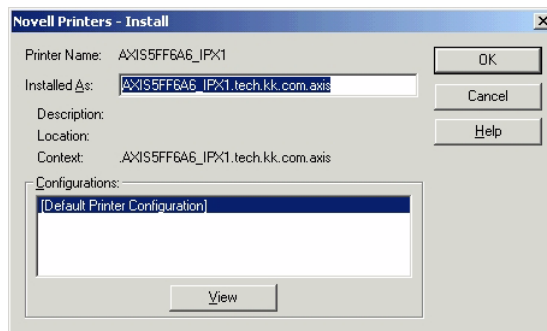

- Click **OK**. The default driver for that printer is then automatically downloaded.

If the printer object does not have a printer driver associated with it, or a driver was not found, you will be prompted to either to choose from a list of printer drivers provided by NDPS or to provide a disk with the appropriate driver.

The Novell Printers dialog appears with the new printer, e.g. **AXIS5FF6A6_IPX1** in the installed list.

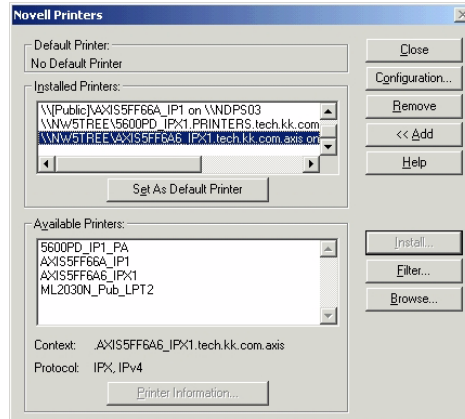

- Click **Close**. In the Novell Printer Manager window the new installed NDPS printer appears with the name e.g. **AXIS5FF6A6_IPX1** and is available for print jobs.

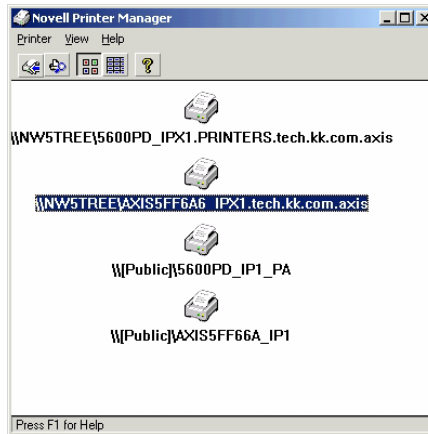

- Verify by clicking **Start - Settings - Printers** on the workstation.

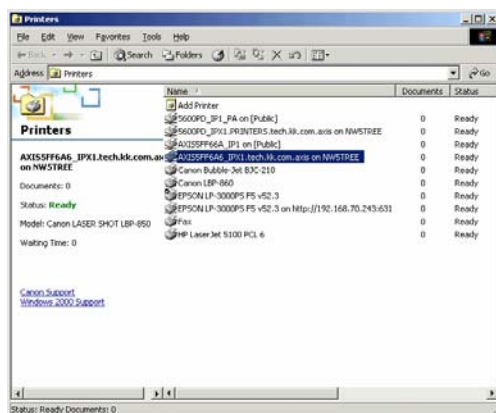

Using the Add Printer Wizard

- Click **Start** on your workstation, select **Settings =>Printers**. There might be some differences regarding this menu depending of MS Operating System you are running.
- Start the Add Printer Wizard on the workstation. The Add Printer Wizard dialog will appear. Click **Next**.
- Select **Network printer** and click **Next**.

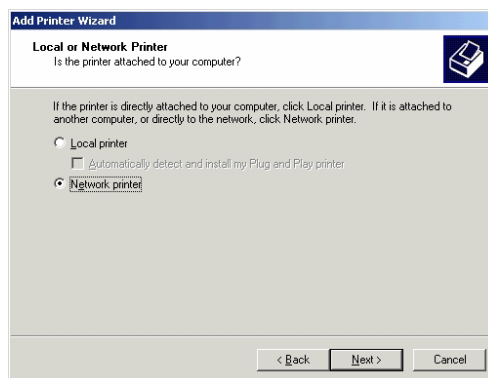

- Click **Next** again in the **Locate Your Printer** dialog (Win2000/XP) or press the **Browse** button (Win9X)
- Browse to the **NDPS Printers**. Expand either the **NDPS Controlled Access Printers** or the **NDPS Public Access Printers** folder, select your newly installed NDPS printer and follow the instructions.

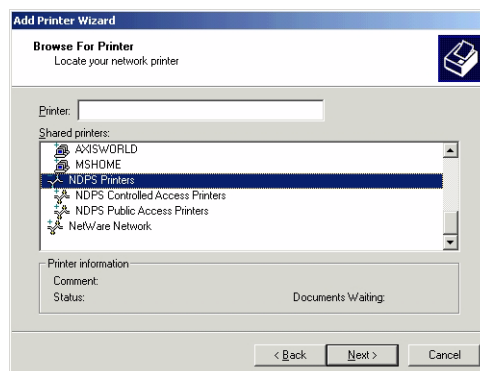

When you have completed these steps, you are ready to start printing.

Notes:

- The Public Access print servers are immediately available for everyone on the network
- The Axis Gateway Configuration Utility is an installation and configuration tool for NDPS printers in the NetWare environment.
The Axis Gateway will appear in NetWare 5.1 and later releases. You can download the Axis Gateway Configuration Utility for use with earlier versions of NetWare from www.axis.com.
- To print using TCP/IP, Axis print server firmware 6.1 or later is required. In order to print using IPX/SPX, Axis print server firmware 5.51 or later is needed.

Setup using iPrint

iPrint is Novell's next generation of printing software that lets users print to and from all destinations.

A standard Web page displays available printers to the user. By clicking a printer, the iPrint client is installed (if not installed previously), the printer's driver is downloaded, and a printer is created in the user's Printer folder, enabling the user to send documents to the printer from any application on the desktop.

Before setting up iPrint printers, make sure that you meet all the iPrint Setup requirements. See the Novell iPrint Administration Guide for instructions on installing, configuring, and customizing iPrint.

AXIS Print servers can be installed as iPrint printers, either by using the Novell LPR gateway (LPR on IP) or the AXIS Gateway Configuration Snap-in for iPrint.

Axis provides two free Snap-ins for iPrint:

- **AXIS LPR Gateway Configuration**
- **AXIS IPP Gateway Configuration**

When you install Service Pack 6 (16 April 2003) for NetWare 5.1 or later and Service Pack 3 (16 April 2003) for NetWare 6.0 or later, the AXIS LPR Gateway Configuration will automatically be installed and configured on the NetWare Servers and ready for use.

The AXIS IPP Gateway Configuration Snap-in for NetWare 6.0 can be downloaded for free from www.axis.com. Follow the instructions below to install the AXIS IPP Gateway Configuration Snap-in for NetWare 6.0, if you want to add it in your iPrint environment.

Installing AXIS IPP Gateway Configuration Snap-in for NetWare 6.0

1. Download the free **axisIPP-snap-in.zip** file from www.axis.com and unzip it in a temporary directory.
2. Make sure the the NetWare Enterprise Web Server was previously installed on the server. Otherwise, install it.

3. Novell iPrint uses the NDPS infrastructure, so make sure that all the NDPS requirements have been met:
 - Make sure that the BROKER.NLM is loaded. If it isn't, type LOAD BROKER in the server console prompt and select the name of the Broker.
 - Make sure that the NDPS Manager object is created in the Novell Directory Services (NDS) tree. Refer to your Novell documentation for creating this object.
 - Make sure that the NDPSM.NLM is loaded. If it isn't, type LOAD NDPSM in the server console prompt and select the appropriate NDPS Manager.
4. Shutdown Tomcat and the NetWare Enterprise Web Server on the NetWare file server by executing the following commands:

Type "NSWEBDN" <Enter>
Type "TOMCAT33 -STOP" <Enter>
Type "NVXADMDN" <Enter>
5. Map the next available drive (e.g. G:) to the root of volume SYS on your NetWare server.
From the temporary directory where **axisIPP-snap-in.zip** has been unzipped, run the batch file **AxisIPP.bat** (default G:).
If the drive G: is not available, you have to edit the batch file and change the drive to next available one.
Check that each line in the batch file is executed without failure.
6. Restart Tomcat and the NetWare Enterprise Web Server on the file server by executing the following commands:
Type "TOMCAT33" <Enter>
Type "NVXADMUP" <Enter>
Type "NSWEB" <Enter.
7. Access the iManager Web page on the NetWare server by opening the following URL:
<https://<IP address of NW server>:2200/eMFrame/iManager.html>
You have to authenticate.
8. Click on **iPrint Management** on the left pane and select **Create Printer**.
9. On the right pane, verify that the newly installed **AXIS IPP Gateway Configuration** is under the **Gateway type** drop-down menu.
If not, it may be necessary to restart the NetWare server.

Now you are ready to use the AXIS IPP Gateway Configuration for installing iPrint printers. You have to have **Administrator rights** to install the printers through iPrint.

**Install a printer with
AXIS IPP Gateway
Configuration Snap-
in**

1. Use an AXIS 5500/AXIS 5550 and connect a printer to any port.
2. Connect the print server to the network.
3. Connect the power adapter.
4. Start the printer and the print server.
5. Log in as Admin.
6. Use a Web browser and the local host URL to login into iManager on your NetWare server.
7. Open your browser to the following URL:
https://<IP address of NW server>:2200/eMFrame/iManager.html
You have to authenticate.
8. Click on **iPrint Management** on the left pane.
9. Click on **Create Printer**.
10. Choose a name of your choice for the printer
11. Choose the context where the printer will be installed.
12. Browse for the NDPS Manager and select it.
13. In the **Gateway Type** drop-down list, choose the **Axis IPP Gateway Configuration**. Press **Next**.
14. In the Printer URL, you may choose either the IPP version 1.0 format:
http://<IP address of your print server>:631/lptx
or the IPP version 1.1:
ipp://<IP address of your print server>/lptx
where x is the port number. Click **Next**.
15. Select default drivers for your printer. Click **Next** and **OK**.

**Install a printer using
AXIS LPR Gateway
Configuration Snap-
in**

1. Use an AXIS 5500/AXIS 5550 and connect a printer to whatever port you want.
2. Connect the print server to the network.
3. Connect the power adapter.
4. Start the printer and the print server.
5. Log in as Admin.
6. Use a Web browser and the local host URL to login into iManager on your NetWare server.
7. Open your browser to the following URL:
https://<IP address of NW server>:2200/eMFrame/iManager.html You have to authenticate.
8. Click on **iPrint Management** on the left pane.

9. Click on **Create Printer**.
10. Choose a name for the printer.
11. Choose the context where the printer will be installed.
12. Browse for the NDPS Manager and select it.
13. In the **Gateway Type** drop-down list, choose the **Axis LPR Gateway Configuration**. Click **Next**.
14. Choose either the IP address or the DNS Name for your print server.
15. Under **Printer name**, select the physical printer port, e.g. LPT1 or USB1, or logical printer port pr1–pr8 using the drop-down list. Click **Next**.
16. Select default drivers for your printer. Click **Next** and **OK**.

Installing the iPrint Printer on the Workstation

An iPrint printer can be locally installed on the workstation in two ways:

- Using the iPrint Client
- Using the MS Add Printer Wizard at the workstation. See “Using the Add Printer Wizard” on page 60.

Installing the iPrint Printer using the iPrint Client.

In order for users to use iPrint, they need to install the Novell iPrint Client software and a printer. When a user selects a printer to be installed by iPrint, iPrint checks to see if the Novell iPrint Client software is installed and then installs it if necessary. Then the printer driver is downloaded and the printer is installed in the user's Printer folder.

In order for iPrint to work properly, the workstation should have the following:

- Windows 95/98/Me or Windows NT/2000/XP
- Web browser with JavaScript enabled:
 - Microsoft Internet Explorer 5.0 or later
 - Netscape 4.76 (iPrint is not supported on Netscape 6)

The user should use the following iPrint url:

http://<IP address of your NW server>:631/IPP

1. From a Netscape or Internet Explorer browser, enter the provided URL. A Web page displays a listing of available printers to install and a link to install the client software.
2. Select **Install iPrint client software** to locally install the iPrint printers. If you try to install a printer before installing the iPrint client software, you will be prompted to install the client software first. If you associate a printer driver with a printer being installed, the driver is automatically installed on the user's workstation. If the driver already exists, that driver is overwritten even if it is a newer driver.
3. After installing a printer, it is added to the user's **Printer folder**. Users can print to the printer by selecting it from any application.

Basic Setup with AXIS NetPilot

Install the AXIS NetPilot software on your computer. AXIS NetPilot runs on Windows 98 and Windows NT.

- Starting the Installation** Follow the instructions below to install the AXIS 5500/AXIS 5550 with AXIS NetPilot:
1. Start AXIS NetPilot by double-clicking the NetPilot icon, which is located in the folder where you installed AXIS NetPilot.
 2. Locate the Axis Network Print Server in the 'New Axis Units' folder. Select it and click the **Install** button on the AXIS NetPilot toolbar. If your network is large, it could take a few seconds before the print server appears in the folder.
 3. Choose the **with Installation Wizard** option.

The AXIS NetPilot Installation Wizard guides you through the installation process. The following options are available:

Note:

The number of options varies according to the number of environments you enable.

- | | |
|-------------------|---|
| Print Server Name | The default print server name consists of the characters 'AXIS' followed by the last six digits of the serial number. If you want to change the print server name, just type the new name in the available text field. |
| Environments | Choose which networking environments you want to configure the Axis Network Print Server for, e.g. NetWare, TCP/IP, Windows or Macintosh. If your network comprises various different platforms, you can enable any combination of environments. |
| NetWare NDS | Place NetWare Print Queues on a specific bindery server, or alternatively into an NDS Tree. |
| The IP address | Choose the method the Axis Network Print Server should employ for obtaining an IP address. DHCP, ARP, RARP, BOOTP and Auto-IP are supported. You can also select to set the IP address manually. Refer to <i>"Assigning an IP Address to the Print Server"</i> on page 15 for further information about setting the IP address. |

Print Queues The Axis Network Print Server uses the print server name followed by the printer port as the default Print Queue names and print server port names. If you want to change the default printer queue names, just type the new names in the available text fields.

AXIS 5500

Environment	Default Names
NetWare	AXIS1A0003_USB1_Q
Windows	AX1A0003.US1
AppleTalk	AXIS1A0003_USB1

AXIS 5550

Environment	Default Names
NetWare	AXIS1A0003_USB1_Q
	AXIS1A0003_LPT1_Q
Windows	AX1A0003.US1
	AX1A0003.LP1
AppleTalk	AXIS1A0003_USB1
	AXIS1A0003_LPT1

Default Print Queue Names and Print Server Port Names
for each operating environment.

Test Page The final user prompt in the Installation Wizard allows you to print a test page through NetWare. The test page displays the name of all the NetWare servers the Axis Network Print Server is connected to and shows the status of each connection.

Unless you want to connect or create additional printing queues, the installation for the NetWare environment is now completed.

Notes:

- The parameters entered during installation are not permanent; they can be altered at any time according to your network printing requirements.
- No serious or permanent damage will be caused if you make a mistake during installation. If you find, at any time, that printing is not satisfactory, the parameters can easily be changed to tune the system to your requirements.
- For information on advanced functions, please refer to the AXIS Network Print Server Technical Reference. You can download this or other technical information over the Internet by accessing www.axis.com

Advanced Installation using AXIS NetPilot

Having installed your Axis Network Print Server print server in accordance with the basic installation procedures described in *Basic Setup with AXIS NetPilot*, on page 65, your Axis Network Print Server print server should now feature in the 'Network Print Servers' folder located in the AXIS NetPilot main window.

NetWare Network Environment Window

The NetWare Network Environment window allows you to connect additional print queues to your Axis Network Print Server as well as create new ones.

Follow the steps below to gain access to the NetWare Network Environment window:

1. Select the required Network Print Server from the 'Network Print Server' folder.
2. Choose **Network** from the Setup menu or click on the **Network** icon on the AXIS NetPilot's toolbar.
3. If you are not logged on to your NetWare file server, a dialog box will ask you to log on.

The Axis Network Print Server periodically updates the configuration by scanning the NDS tree or, in the case of NetWare versions 3.x, the designated file servers.

Connecting Print Queues

Follow the steps below to connect a print queue to the print server port:

1. Open the NetWare 'Network Environments' window.
2. Select the print server port you want to connect.
3. Click the **Connect...** button. The **Connect NetWare Print Queues** window appears.

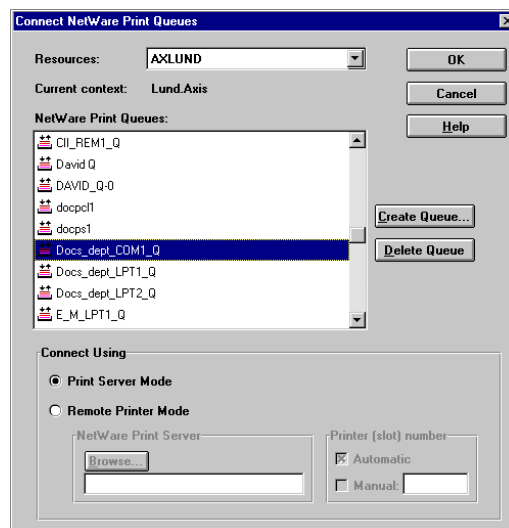

The AXIS NetPilot Connect NetWare Print Queues window

4. Select the tree or server location of the print queue from the **Resources** box.
5. Select an existing print queue to connect to the server port, or create a new print queue by clicking on **Create Queue...** If you have selected an existing queue, advance to step 8. Continue with step 6 only if you want to create a new queue.
6. Type the queue name in the **Create Queue** dialog window. If you want to create a queue in the NDS tree you must also enter the name of the volume where the queue will be located. Click **OK**.
7. Select the newly created queue from the queue list.
8. Select **Print Server Mode** or **Remote Printer Mode**. If you selected **Print Server Mode**, advance directly to step 11, otherwise continue with step 9.
9. Select an appropriate NetWare Print Server name, that will be associated with the Axis Network Print Server print server, by using the **Browse...** button.

Notes:

- You cannot type or edit the name manually.
- Make sure that you have PSERVER.NLM running if you selected Remote Printer Mode in step 8.

10. If you want to define a remote printer number slot manually, check the **Manual** box and type the desired number in the box.
11. Click the **OK** button to return to the Network Environments window.

Basic Queue-based printing over IP

Axis print servers with software version 6.0 or later allow users to print in a Pure IP environment using traditional queue-based printing (which usually uses the IPX transport protocol). Note that only NDS queue-based printing is supported.

In the NetWare Pure IP environment, you must use the NetWare Administrator to create the printer, print server and queue objects.

Installing the Axis Network Print Server

Follow the instructions below to install the Axis Network Print Server in the NetWare Pure IP environment:

1. Start the Configuration Wizard from the **User mode** in the Axis Network Print Server Web interface.
2. Click your way through the Wizard until reaching the **NetWare** page.
3. Set the parameters on the NetWare page:
 - PSERVER NDS Tree (example: NW5TREE)
or
PSERVER NDS File Server: (example: FILESERVERNAME)
 - PSERVER NDS Distinguished Name:
(example: AXISXXXXXX.<context>, where <context> is the container where you want to create your print server)

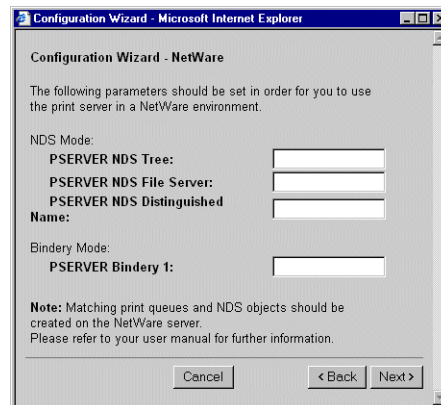

Setting the PSERVER parameters in the Axis Network Print Server Web interface.

4. Use the NetWare Administrator to create the printer, print server and queue objects in the NDS tree and then link them together. The **Print Services Quick Setup (Non-NDPS)** utility can be used for this. Go to **Tools** in the NetWare Administrator.

5. Use the Add Printer Wizard on your work station to install the printer on your client. Note that only NDS queue based PSERVER printing is supported. When installing, choose **Network Printer** and browse to the queue you have just created. Alternatively, choose **Local Printer** and select the queue you have just captured.

Any configuration and management of the Axis Network Print Server can be performed from any standard Web browser. Please refer to “*Using a Web browser for Print Server Management*” on page 88.

If both the IPX and IP protocols are enabled in your network and the print server uses DUAL_STACK (enabled by default) as its network transport protocol, then IPX will be chosen. To force the print server to use the IP transport protocol, go to your print server’s Web interface and choose **Admin | Detailed View | NetWare** and change the NetWare Transport Protocol from DUAL_STACK to IP_ONLY. Save and exit when finished.

Note:

Pure IP requires that you run NetWare 5 or higher.
--

Queue-based Printing Methods

The following overview explains the advantages and limitations of the two supported queue-based printing methods.

Print Server Mode

The Axis Network Print Server logs in to a file server(s) and repeatedly polls the print queues for print jobs. In this fashion, the Axis Network Print Server emulates a NetWare print server, which is a workstation running PSERVER. It provides high printing speed with low network load and is the recommended mode for medium to large sized networks. Each print server in PSERVER mode takes one NetWare user license.

Advantages

- High performance: up to 1 Mbyte/s

Limitations

- In bindery mode, this printing method requires a NetWare user licence for each Axis Network Print Server to file server link.

Remote Printer Mode

The Axis Network Print Server acts as Remote Printer for PSERVER.NLM running on the NetWare file server, or to a dedicated workstation running PSERVER.EXE. In this fashion, the Axis Network Print Server emulates a workstation running the NetWare remote printer software RPRINTER, or NPRINTER. This mode is only recommended for small networks where the number of NetWare user licences is a major issue.

Advantages

- NetWare user licences are not required.

Limitations

- Lower performance, typically 20 - 70 kbytes/s for NLM and higher network load.

Using Novell Utilities After installing the Axis Network Print Server into the NetWare environment, you can manage your Axis Network Print Server, using either Novell's NetWare Administrator, or PCONSOLE.

NetWare Administration Some useful features provided by the NetWare Administrator are described in more detail below:

Printer Status

The Printer Status menu, detailed below, shows the status of an active print job serviced by an Axis Network Print Server network print server. It displays detailed information concerning the active job including, Print Queue, print job description, size of print file, percentage of job completed, etc. You can also abort or pause the print job from this menu.

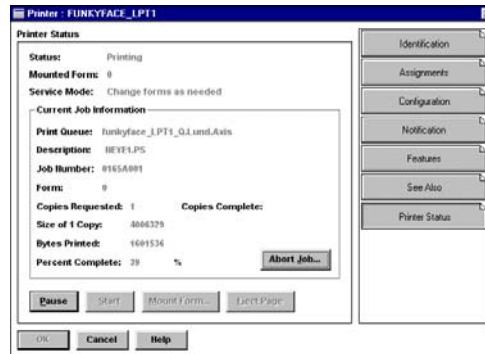

Notification

You can use the NetWare Administrator to enable or disable status notification messages for printers connected to the AXIS 5500/AXIS 5550, e.g. Busy, Off-line, Out of paper, Paper jam, etc. You can also add or remove print job owners and administrators from the list of persons to be notified.

Print Layout

You can view installed AXIS 5500/AXIS 5550 and their relative print queues for any NetWare Organizational Unit. You can also display summary information by right-clicking on the printer object you want to examine.

Section 7 Adding Printers in UNIX/Linux

Print Tools

For printer configuration, *printtool* and *printconf* are the most common. How they are invoked depends on which distribution and window manager you use.

AIX *SMIT* is the recommended printing tool. It contains an integrated printer driver list, but does not have printer detection functionality.

Instructions:

Type the command `smit` in a Terminal window, then click **Print Spooling**.

Debian *printtool* is the recommended printing tool. The program contains an integrated printer driver list, but does not have printer detection functionality.

Instructions:

Type the command `printtool` in a Terminal window to start the graphical version.

HP UX *Sam* is the recommended printing tool. It doesn't provide an integrated printer driver list, nor printer detection functionality.

Instructions:

Type the command `sam` in a Terminal window, click **Printers and Plotters** and then click **Actions** and **Add_Remote Printer/Plotter**.

Mandrake *printerdrake* is the recommended printing tool. It contains an integrated printer driver list, but does not have printer detection ability.

Red Hat *printconf* is the recommended printing tool. The program contains an integrated printer driver list, but does not have printer detection functionality.

Instructions:

Type the command `printconf-gui` in a Terminal window to start the graphical version.

You can also run `printconf` as a text-based application if you do not have the X Window System installed, or if you prefer the text-based interface. Log in as `root` (or use the command `su` to temporarily change to the root user), and type the command `/usr/sbin/printconf-tui` from a shell prompt.

Solaris 9 The printing tool is called *Printer Administrator*. This operating environment has an integrated printer driver list, but does not have printer detection functionality.

Instructions:

Type the command `/usr/sadm/admin/bin/printmgr` in a Terminal window.

SuSE *YaST2* is the recommended printing tool. It contains a printer driver list as well as printer detection capability.

Instructions:

To start the Printer Configuration tool, select this from the Desktop:

YaST2 menu button (on the panel) | In Yast Control Center | Hardware | Edit Printers

Notes:

- A versatile IPP client for UNIX/Linux is CUPS. It can be downloaded from the Common Unix Printing System's Web site at www.cups.org
- If you don't find your specific printer in your distribution, have a look at <http://www.linuxprinting.org/database.html>

Typical Invocation via a Windows Manager

Using the Mandrake 8.2 distribution (with CUPS installed) and the KDE windows manger as an example, a typical set-up begins with starting Mandrake Control Center.

Click **Hardware | Printer** and the *Printerdrake* application will be invoked.

Click **Expert Mode** to be able to add a network printer.

Click the **Add a new printer** button.

Print Queues Five types of print queues can be configured in the Mandrake distribution:

- Local Printer
- Printer on remote lpd server
- Network printer (TCP/Socket)
- Printer on SMB/Windows 95/98/NT server
- A printer device URI

1. Select the **Network printer** radio button and click **Next**.
2. Enter the IP address or host name of the print server as well as the port you want to use. Port numbers available for TCP/IP are:

Port number	USB port	Parallel port
AXIS 5500	9902	—
AXIS 5550	9902	9900

Also see *"TCP Ports Opened for Raw Printing"* on page 158.

3. Click **Next**. Fill in data to help users identify the printer, i.e. name, description and location. Click **Next**.
4. Select printer model and click **Next**.
5. Configure the printer and click **Next**.
6. The printer is set up. Click **Finish** and the printer is accessible.

Typical Invocation from a Terminal Window

Still using Mandrake as an example, open a Terminal Window and type the command `printtool`. If you are in a terminal window, the graphic version will start (as described above). If you do not have the X Window System installed, the command will start a text based version. The same information as was described above will be needed.

Note: In Mandrake, even if you type `printtool` at a shell prompt, `printerdrake` will automatically start.

Debian 3.0

Debian offers a choice between plain LPD, LPRng and CUPS. There are several printer configuration tools in this distribution, e.g. the *apsfilter* (version 5 or later), which adds support for LPRng and Ghostscript's uniprint driver scheme. Red Hat's *printtool* is also supported, for those who prefer GUI administration tools.

For LPRng, LPD and CUPS use the **Printtool**.

- Invocation
1. From the Gnome desktop, select Main Menu (on the panel) => Debian menus => Apps => System => Printtool.
 2. On the KDE desktop, select the Main Menu (on the Panel) => System => Debian => Printtool.
 3. Open a terminal window and type the command `printtool` (in XTERM or Gnome).

Print Queues Five types of print queues can be configured with *printconf* in the Debian distribution:

- Local Printer
- Unix Printer (lpd Spool)
- Windows Printer (SMB)
- Novell Printer (NCP Queue)
- JetDirect Printer

- Adding a Remote Unix Printer
1. Start *printtool* and click **Add**.
 2. Select **Remote Unix (lpd) Queue** from the **Printer Type** menu, and click **OK**.
 3. Text fields for the following options appears:
 - **Printer name** – Enter a unique name for the printer. (The name cannot contain spaces and must begin with a letter. Valid characters are a - z, A - Z, 0 - 9, -, and _.
 - **Remote Host** – The hostname or IP address of the remote machine to which the printer is attached.
 - **Remote Queue and input filter** – The remote printer queue and input filter.
 4. Click **Next** to continue.
 5. Click **Select** to choose a printer driver and to set it up. Click **OK**. Finally, click **Test** and print a test page.

Red Hat 7.3

Printtool has been replaced by **Printconf**. The utility maintains the `/etc/printcap` configuration file, print spool directories, and print filters.

Note: If you type `printtool` at a shell prompt, `printconf` will automatically start.

- Invocation
1. On the Gnome desktop, select the Main Menu button (on the Panel) => Programs => System => Printer Configuration to start the graphical version.
 2. On the KDE desktop, select the Main Menu button (on the Panel) => Red Hat => System => Printer Configuration to start the graphical version.
 3. Type the command `printconf -gui` at a shell prompt (for example, in an XTerm or a Gnome terminal) to start the graphical version.
 4. You can also run `printconf` as a text based application if you do not have the X Window System installed, or you just prefer the text based interface. To run it, log in as root (or use the command `su` to temporarily change to the root user), and type the command `/usr/sbin/printconf -tui` from a shell prompt.

Print Queues Five types of print queues can be configured with `printconf` in the Red Hat distribution:

- Local Printer
- Unix Printer (lpd Spool)
- Windows Printer (SMB)
- Novell Printer (NCP Queue)
- JetDirect Printer

Important!

- Do not edit the `/etc/printcap` file. Each time the printer daemon (lpd) is started /restarted, a new `/etc/printcap` file is dynamically created.
- If you want to add a printer without using `printconf`, edit the `/etc/printcap.local` file. The entries in `/etc/printcap.local` are not displayed in `printconf` but are read by the printer daemon.
- If you upgrade your system from a previous version of Red Hat Linux, your existing configuration file is converted to the new format used by `printconf`. Each time a new configuration file is generated by `printconf`, the old file is saved as `/etc/printcap.old`.
- If you add a new print queue or modify an existing one, you need to restart the printer daemon (lpd) for the changes to take effect.
- Clicking the Apply button saves any changes that you have made and restarts the printer daemon. The changes are not written to the `/etc/printcap` configuration file until the printer daemon (lpd) is restarted. Alternatively, you can choose File => Save Changes and then choose File => Restart lpd to save your changes and then restart the printer daemon.
- If a printer appears in the main printer list with the Queue Type set to INVALID, the printer configuration is missing options that are required for the printer to function properly. To remove this printer from the list, select it from the list and click the Delete button.

- Adding a Remote Unix Printer** To add a remote UNIX printer, such as one attached to a different UNIX/Linux system on the same network, click the **New** button in the main `printconf` window.
- Select **Unix Printer** from the **Queue Type** menu, and click **Next**.
- Enter a unique name for the printer in the **Queue Name** text field. The printer name cannot contain spaces and must begin with a letter a through z or A through Z. The valid characters are a through z, A through Z, 0 through 9, -, and _. Click **Next**.
- Text fields for the following options appear:
- **Server** – The hostname or IP address of the remote machine to which the printer is attached.
 - **Queue** – The remote printer queue. The default printer queue is usually `lp`.
- By default, the **Strict RFC1179 Compliance** option is not chosen. If you are having problems printing to a non-Linux `lpd` queue, choose this option to disable enhanced LPRng printing features.
- Click **Next** to continue
- The next step is to select the type of printer that is connected to the remote system.

Important!

The remote machine must be configured to allow the local machine to print on the desired queue. As root, create the file `/etc/hosts.lpd` on the remote machine to which the printer is attached. On separate lines in the file, add the IP address or hostname of each machine which should have printing privileges.

- Selecting the Print Driver** If you are configuring a local printer, select the print driver from the list. The printers are divided by manufacturers. Click the arrow beside the manufacturer for your printer. Find your printer from the expanded list, and click the arrow beside the printer name. A list of drivers for your printer will appear. Select one. Then finish the Wizard in the usual manner.

SuSE 8.0

The printing system on SuSE Linux is based on an `apsfilter`, with some enhancements; SuSE's `apsfilter` will recognize all common file formats (including HTML, if `html2ps` is installed).

There are two ways to setup printers on SuSE systems:

- YaST2 will let you configure "PostScript", "DeskJet" and "Other printers", supported by Ghostscript drivers; it's also possible to setup HP's GDI printers (DeskJet 710/720, 820, 1000, via the "ppa" package). YaST2 will provide `/etc/printcap` entries for every printer ("raw", "ascii", "auto" and "color", if the printer to configure is a color printer). YaST2 will create spool directories and it will arrange `apsfilterrc` files, where you're able to fine tune some settings (Ghostscript preloads, paper size, paper orientation, resolution, printer escape sequences, etc.). With YaST2 it's also possible to setup network printers (TCP/IP, Samba, or Novell NetWare Printer).
- SuSE includes the regular `SETUP` program from the original `apsfilter` package (with some enhancements); run `lprsetup` to invoke this configuration script. Once you get accustomed to its GUI, you'll be able to configure local and network printers.

Invocation of YaST2 On the Gnome desktop select YaST2 Menu Button (on the panel) => Yast Control Center => Hardware => Edit Printers to start the Printer Configuration tool.
On the KDE desktop select YaST Menu Button (on the panel) => Yast2 modules => Hardware => Edit printers to start the graphic version.

Print Queues SuSE and YaST2 differ between these printer connections:

- Local printers (Parallel, USB, Serial and Disk File)
- LPD protocol network printing (Forward queue to a remote LPD and Prefiltered queue for an LPD forwarding queue)
- Other network printing (Samba/Windows, Novell)

The SuSE installation manual explains the setup procedures in detail.

AXIS axinstall Script

Having performed the basic TCP/IP setup procedures as defined earlier in this manual, you are now able to print in interactive mode using PROS, LPR, FTP or Reverse Telnet protocols. However, if you want to integrate the AXIS 5500/AXIS 5550 with your host spooler, you can use the Axis automatic installation script *axinstall*. The *axinstall* script is available from ftp://ftp.axis.com/pub_soft/prt_srv/utility/axinstall/latest/

After executing this script, the printer connected to the print server will appear as though it is directly connected to the host printer spooler.

If you intend to use the print server in a multi-protocol environment, refer to the chapters pertaining to the respective operating systems in this manual.

When the *axinstall* script has been downloaded to your host, execute the script with this command:

```
sh axinstall or sh ./axinstall (depending on your system).
```

You will be guided through the installation by a step-by-step procedure. During the installation you will be asked to select a print method; we suggest you choose LPD or, for more functionality, use the PROS filter or named pipe methods. Please refer to the following pages if you need guidance on the choice of print methods.

Note: NLPRng is not supported by axinstall.

The *axinstall* script will suggest one of the systems listed below when started. If you do not find the suggestion appropriate, then manually select any of the systems listed.

```
1...SunOS 4 (SUN BSD, Solaris 1.x)
2...SunOS 5 (SUN SYS V, Solaris 2.x)
3...AIX (IBM RS/6000, BULL DPX 20)
4...HP-UX (HP 9000)
5...BOS (BULL DPX 2)
6...DEC OSF/1 (Digital Equipment, Alpha)
7...ULTRIX (Digital Equipment, DEC)
8...IRIX (Silicon Graphics, SGI)
9...SCO UNIX (Santa Cruz Operation)
10...SCO UnixWare 2.x
11...SCO UnixWare 7
12...SCO OpenServer
13...FreeBSD (Berkeley UNIX)
14...Linux

15...Generic BSD (Berkeley UNIX)
16...Generic SYS V R3 (UNIX System V Release 3)
17...Generic SYS V R4 (UNIX System V Release 4)
```

Systems supported by axinstall

Print Methods on TCP/IP Networks

The AXIS 5500/AXIS 5550 supports several different print methods in the TCP/IP environment. *axinstall* will suggest a print method suitable for your particular UNIX/Linux system, but you might want to use another method depending on your printing requirements (banner pages, status logging, etc).

The diagram below shows the alternative data paths taken by some of the UNIX/Linux print methods. This illustrates some of the advantages and limitations of the different methods. Use the following information to determine which method to adopt.

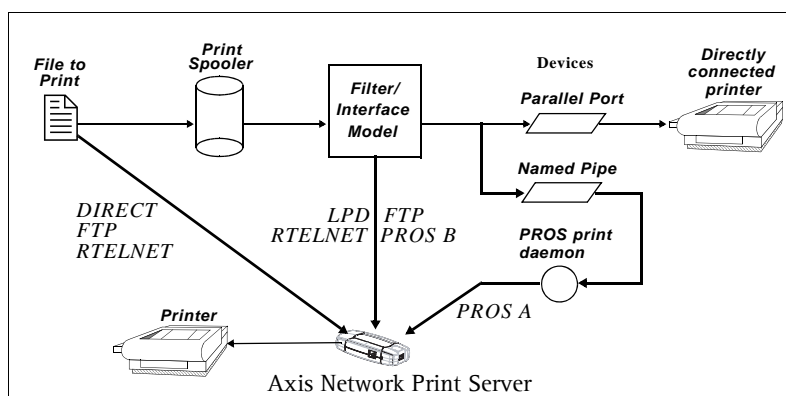

Illustration of different UNIX/Linux print methods

LPD The Line Printer Daemon is a protocol for transferring print jobs between hosts. This is the recommended method for UNIX/Linux systems, but some System V versions do not support LPD.

Advantages:

Easy to set up – install the AXIS 5500/AXIS 5550 as a remote queue in System V, or add a remote printer to `/etc/printcap` using the `rm` and `rp` fields (BSD).

Limitations:

Spooler features, and `printcap` or `lpr` options (BSD) such as multiple copies, are not available.

FTP The File Transfer Protocol is used for transferring files between hosts.

Advantages:

Uses industry standard network software on the host.

Limitations:

No printer status logging. In the case of BSD it may conflict with other input or output filters and does not allow both input and output filters. In System V no filters or interface programs can be used.

PROS A protocol developed at Axis. Comes in two versions; *named pipe* (PROS A) and *filter* (PROS B).

PROS A Advantages The AXIS 5500/AXIS 5550 appears as a device to the system. This makes all filter and model options available. It provides accounting and status logging. Supports bi-directional printing. The printer information read back can be viewed in a log file.

PROS A Limitations A 'C' compiler is required to build the PROS A drivers.

Note:

You can download a 'C' compiler from <http://www.gnu.org/>.

PROS B Advantages It provides accounting and status logging. Supports bi-directional printing. The printer information read back can be viewed in a log file.

PROS B Limitations A 'C' compiler is required to build the PROS B drivers and in the case of BSD, it may conflict with other input or output filters. It does not allow both input and output filters. Interface programs can not be used in System V.

Reverse Telnet Often used for printing via a terminal server printer port. Only recommended if you already have a Reverse Telnet driver installed.

Advantages: Easy to set up with previously installed Reverse Telnet drivers.

Limitations: No status logging. Drivers are not supplied with the print server. Existing drivers may be slow.

Other UNIX/Linux Systems Most UNIX/Linux systems resemble either BSD or System V and so with some ingenuity, a solution can also be devised for other variants.

If the system has BSD socket type networking support, then `prosbbsd` (in the `bsd` directory of the AXIS 5500/AXIS 5550) can be used as a starting point. It receives print data from `stdin`, and writes a log file to `stderr`. Nothing is written to `stdout`.

Alternatively, FTP may be used. It is a good idea to use `bsd/ftp_bsd` or `sysv/ftp_sysv` as a starting point.

IBM MVS Systems A sample JCL script, `jcllex`, is available in the `mvs` directory of the print server. It gives an example of how to print a file from an MVS mainframe to an AXIS 5500/AXIS 5550 using FTP.

Section 8 Adding Printers in OS/2

This section describes how to set up your print server for printing in the OS/2 environment.

Continue with the instructions presented in the table below:

Protocol	See ...
TCP/IP	"TCP/IP Printing" on page 82
NetBIOS/NetBEUI	"NetBIOS/NetBEUI Printing in OS/2" on page 82

TCP/IP Printing

Having assigned an IP address to the print server, you are now ready to install it for TCP/IP printing in the OS/2 environment. The print server supports LPR Printing using the `lprportd` service method.

Installing the Axis Network Print Server

Follow the instructions below to install the print server using the `lprportd` service method:

1. Open the **OS/2 System** window, select **TCP/IP** and **TCP/IP Configuration**.
2. Select **Printing**, type a number, e.g. 1, in the **Maximum number of LPD ports** field. The **Remote print server** and **Remote print server's printer** fields should remain empty.
3. Select **Autostart**, select **lprportd**, click the **Autostart** check box and select **Detached**.
4. Exit and Save.
5. Restart your OS/2 client.

Creating a print queue

Continue with the instructions below to create a print queue:

1. Open the **Template** group. Create a new printer from Templates by dragging the **Printer** icon to the desktop with the right mouse button.
2. Select a printer driver and double-click a free **Output port**, for instance `\PIPE\LPD0`.
3. Enter the host name or the IP address of the print server in the **LPD server** field.
4. Enter one of the print server's logical printer names, for example `pr1`, in the **LPD printer** field.

NetBIOS/NetBEUI Printing in OS/2

AXIS Print Utility for OS/2 is the tool to use for NetBIOS/NetBEUI printing in OS/2 environments. This tool can be fetched from

www.axis.com => Software => Discontinued products. Install it if you have not already done so.

If you want to change the default name or any of the print server's default parameters, you can do so using any standard Web browser or WinOS/2 window under OS/2.

Refer to *Section 10 Management and Configuration*, on page 88, for more information.

The AXIS Print Utility for OS/2 is not needed on the client platforms when using a client-server configuration.

About AXIS Print Utility for OS/2

AXIS Print Utility for OS/2 is an application for NetBIOS/NetBEUI printing in the OS/2 environment. Its allows you to:

- Install and maintain the print server's printer port as an OS/2 printer port.
- Capture and monitor print jobs directed to the print server's ports.

Print jobs are directed through a spool directory located on your local hard disk (peer-to-peer mode), or on the file server (client-server mode). The printer port status of your print server can be monitored and pop-up notification messages can be generated, keeping you informed of completed print jobs or any problem condition.

Notes:

- The NetBEUI protocol must be active. If not, use MPTS/LAPS (LAN Server) or SETUP (LAN Manager) to activate it.
- If you are using OS/2 version 2.x and wish to print through TCP/IP, we recommend that you use the IBM TCP/IP for OS/2 product. It supports the LPD and interactive FTP print methods.

Installing the Axis Network Print Server

1. When AXIS Print Utility for OS/2 is running, click **Install** to install your AXIS 5500/AXIS 5550.

Ports available	USB port	Parallel port
AXIS 5500	US1	—
AXIS 5550	US1	LP1

The port appears in the list as <name>.<port>, where <name> is AX followed by the last six digits of your print server serial number. e.g. AX100086.US1.

2. Select port, then click **Install**.

Repeat this procedure for each server using the print server.

Note:

The AXIS Print Utility for OS/2 must be running in order to print through your Axis Network Print Server. It is strongly recommended that you modify the startup.cmd file, enabling AXIS Print Utility for OS/2 to automatically start when your client is re-booted. Instructions are available in the AXIS Print Utility for OS/2 Readme file.

Creating a Print Queue (OS/2 version 2.x and OS/2 Warp)

1. Double-click the **Templates** folder, then drag the **Printer** icon out to the Workplace Shell (or into a folder) while holding the right mouse button down.
2. Type a name of your choice in the Name field.

Ports available	USB port	Parallel port
AXIS 5500	US1	–
AXIS 5550	US1	LP1

3. Select `\PIPE\<name>.<port>`, from the Port list, and select a printer driver suitable for your printer from the Standard Printer list.
4. Click **OK** to confirm the printer definition.

Sharing the Print Queue

A print queue must be made a shared resource before it can be accessed from other clients or servers. The following three examples show how you can share your printer resources:

Open an OS/2 window and issue the following command:

```
NET SHARE <queue_name> /PRINT
```

Where `<queue_name>` is the name of the queue created on the previous side.

To share a printer resource when using OS/2 Warp with IBM Peer service, follow the steps below:

1. Click the right mouse button on the printer object.
2. Select **Share** and then **Start sharing**. In the dialog box, enter a Description.
3. Select the check-box **Start sharing at LAN workstation start-up**.
4. Click **OK**.

To share a printer resource when using LAN server 4.0, follow the steps below:

1. Open **LAN Server Administration**.
2. Open your domain and then **Resource Definition**.
3. Drag and drop a printer from the template.
4. Enter the Alias name, select a Server name and the previously created Spooler Queue Name.
5. Click **OK**.

The setup is completed and you can now print through your print server.

Section 9 Updating the Firmware

Upgrading the Firmware

You can upgrade the AXIS 5500/AXIS 5550 firmware using one of the following methods:

- AXIS ThinWizard (TCP/IP)
- From the print server's internal Web pages (TCP/IP)
- FTP (TCP/IP)

Note:

Updating instructions are supplied with the firmware release notes.

Upgrading from the Print Server's Internal Web Pages

Follow these instructions to upgrade the firmware of your print server from its internal Web pages (flash loading over the Web):

1. Open your Web browser, enter the IP address of your print server and press **Enter**. (See *"Using a Web browser for Print Server Management"* on page 88 for detailed instructions on accessing your Axis print server on the Web).
2. From the **Admin** mode, click the **Firmware Upgrade** button. From here you can upgrade your print server with the latest available firmware.

Upgrading using AXIS ThinWizard

AXIS ThinWizard 3.0 is a tool that enables batch upgrading of several print servers and can be used for upgrading the print server's firmware in TCP/IP networks.

Follow the instructions below to upgrade your print servers using AXIS ThinWizard:

1. Log in to AXIS ThinWizard.
2. Open the Network Group that contains the print server to be upgraded.
3. Click the **Firmware** button. The Firmware Wizard starts.
4. Browse through the upgrading tips and click **Next >** when you are done. Select **Latest Available Version**. Click **Next >**.
5. Select the servers you want to upgrade, by checking the correct upgrade boxes. Click **Next >**.
6. Enter the default User ID and Password of the servers you selected in the previous step. Select whether you want AXIS ThinWizard to verify the password immediately or when the upgrading job has started, by checking the appropriate box. Click **Next >**.

7. If you do not have a default password, just click **Next >**. If some of your servers use a different User ID or Password than the default entries, they will be displayed in the **Remaining servers** list. Enter the User ID and Password for each individual server. Click **Next >**.
8. Name the upgrade job. This is optional, so you can leave the field blank if you want. Click the **Start** button to start the upgrading job.

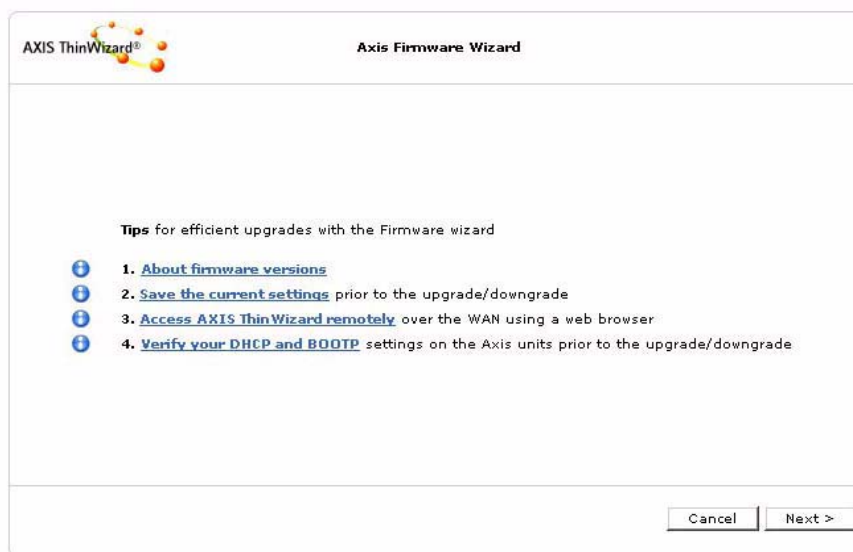

9. You can view the progress of the job in the Event Log.

Refer to “*Using AXIS ThinWizard for Print Server Management*” on page 92, for more information about AXIS ThinWizard.

Upgrading using FTP

To upgrade over the network using FTP you will need a file with the new print server firmware. The name of this file is in the form `product_version.bin`.

Ensure that **FTP Enabled** is set to *yes*. To check this parameter, browse to the print server and select **Admin | Network Settings | Detailed View | TCP/IP Network**.

Caution!

Be careful not to interrupt the file transfer. If the transfer is interrupted, the print server may have to be re-initialized by your dealer.

The objective of this example is to upgrade a print server to firmware version 7.00.

The description from a typical Windows session uses the following *examples*:

- Print server model: AXIS 5550
- IP address of print server: 10.13.4.105
- New firmware version name: 5550_v2_7_00.bin
- Location of firmware and upgrade procedure: c:\Axis

1. From www.axis.com, download the firmware and save it to a new directory on your computer, e.g. `c:\Axis` (if the directory does not exist, create it).
2. Open a command prompt from **Start => Run**. The Run window will appear. Type `cmd` and click **OK**. (Windows 98: Type **command** and click **OK**.) The DOS Command Prompt window will open.
3. Make sure you are working from the correct directory:
type `cd c:\Axis` and press **Enter**.
4. Connect to the print server using ftp:
type `ftp 10.13.4.105` followed by **Enter**.
(Example using print server IP address 10.13.4.105)
5. Enter the user name, the default user is `root`. Press **Enter**. If the default password has been changed then it must also be entered. When you enter the password, it will not be echoed to the screen, nor will the cursor move.
6. Change to binary mode transfer.
Type `bin hash` (or `binary hash`) and press **Enter**.
7. Use the `put` command to upload the upgrade file to the flash location:
(Example using firmware named `5550_v2_7_00.bin`):
Type `put 5550_v2_7_00.bin FLASH` followed by **Enter**. (Note that FLASH is written in capital letters!) A stream of hash (#) marks will appear.

Wait 30 seconds... You will receive a message stating *Transfer complete. Flash programming finished OK*. The print server will restart in five seconds running the new software.

When you see a new **ftp prompt** the procedure has been completed successfully.

8. Type `bye` followed by **Enter** to end the ftp session.

Obtaining the Software

You can obtain all the print server firmware as well as the latest utility software from the following locations:

- <http://www.axis.com>
- your local dealer

Section 10 Management and Configuration

The management and configuration tools that are supported by the Axis Network Print Server allow you to:

- Change the print server parameters, i.e. editing the *config* file
- Receive extended information about the print jobs
- Receive printer port status
- Monitor your printers
- Reset the Axis Network Print Server

Configuration Overview

The method you should use to manage and configure your Axis Network Print Server depends on the operating system protocols of your network. The table below displays which method to use for each supported environment.

Environments	Configuration/Management methods
TCP/IP (UNIX/Linux, Windows, Mac OS)	Web Browser - See page 88 AXIS ThinWizard - See page 92 FTP - See page 94 Telnet - See page 96 SNMP - See page 98
IPX/SPX (NetWare)	Novell Utilities - See page 99
NetBIOS/NetBEUI (Windows)	Web Browser - See page 88
AppleTalk	Web Browser - See page 88 AppleTalk_cfg method - See page 42 Mac-FTP - See page 94

Using a Web browser for Print Server Management

Once you have established the Axis Network Print Server in the TCP/IP environment, as described in “*Assigning an IP Address to the Print Server*” on page 15, you are free to access the Axis Network Print Server Web pages from any standard Web browser.

The Web interface of the Axis Network Print Server is divided into two modes of operation, User mode and Admin mode:

- User** In User mode you can change language, but you have no rights to change any other parameters. However, if you have access rights to the Admin mode, you can change some of the basic parameters from User mode via the Configuration Wizard. This mode is intended for regular users who are only interested in using the print server’s interface for checking print jobs or viewing printer properties. If you want to change any other of the print server’s settings, you must enter the Admin mode.

Admin When in Admin mode, you have access to all the print server's parameters and you can change them to your liking. This mode is intended for network administrators and can be password protected to prevent unauthorized changing of the print server parameters.

Note:

To protect the Admin pages from unauthorized use, it is highly recommended that you change the default password.

This is done from the **Admin | General Settings | General** tab. Enter the password in the Root Password field.

Accessing the Web Pages Follow the steps below to access the internal Web pages of the Axis Network Print Server:

1. Enter the print server's IP address (or host name) in the **Location/Address** field of your Web browser. Press **Enter**
2. The Printer Overview page will appear. Click **Admin** to access the Administration Web pages.

Note:

- You can address the print server's Web interface via **https://** To do this you must enable the SSL/TLS protocols in the Web interface: **Admin | Network Settings | Detailed View | TCP/IP Network** and set the **HTTPS Enabled** parameter to **Yes** (you must have a valid certificate loaded). If you do not have a valid certificate loaded, select **Admin | Security Settings** and click **Create**.

3. If you have changed the User/Password combination, you will be prompted for them. Click **OK**.

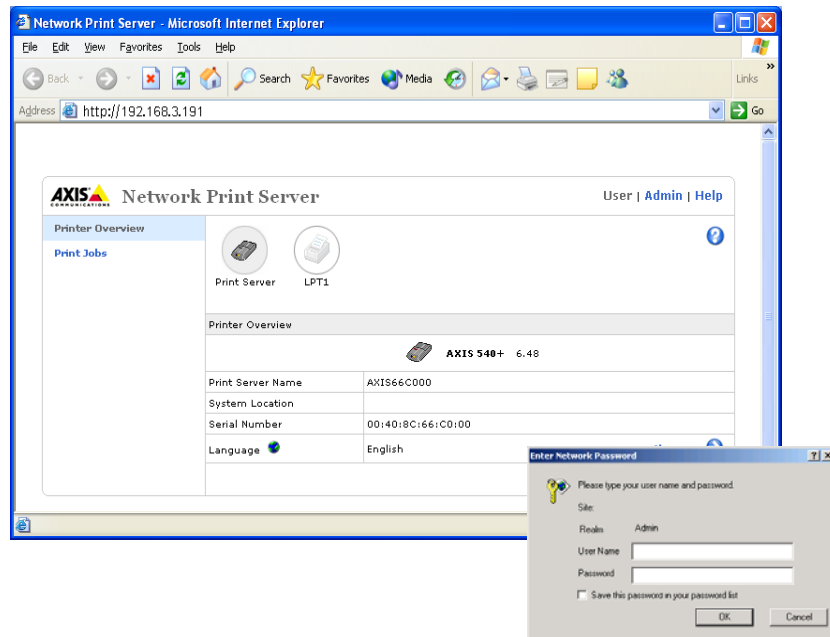

Available Services from the User Mode The following services are available from the User mode. A link to the Axis home page is available from this mode.

Printer Overview The Printer Overview page contains a section that allows you to view the general parameter setting of the Axis Network Print Server, including the print server name and the location of the print server in your organization, if defined.

By clicking the printer icon a printer page opens, allowing you to view the status and the supported capabilities of the connected printer. The extent of this information depends on the printer model. From the printer page, you can also print a test page to the printer.

Print Jobs From the Print Jobs page you can view the status of the current print jobs, including the number of printed bytes and the origin of the print job. You can also view a log of the 20 latest print jobs that includes the user, the printing protocol and the file size. A log that displays the accumulated usage of the connected printers allows you to control the usage of the connected printers.

Help The Help page presents you with basic information about the Axis Network Print Server and the Web user interface. A short description of the Axis installation tools you should use when installing a printer on your PC is also included.

Available Services from the Admin Mode The following services are available from the Admin mode. An additional link to www.axis.com is available from this mode.

This Print Server The This Print Server page contains a section that allows you to view and modify the general parameter setting of the Axis Network Print Server, including the print server name, the node address, the password and the base URL. You can also configure any of the eight logical printers of the Axis Network Print Server. Management operations, like restarting the Axis Network Print Server and resetting its parameters to the factory default settings, are also available.

Caution!

Any network configuration should involve the Network Administrator.

By clicking on the printer icon, a printer page opens, allowing you to view the status and the supported capabilities of connected printer. The extent of this information is depending on the printer model. From the printer page, you can also print a test page to the printer.

Print Jobs From the Print Jobs page you can view the status of the current print jobs, including the number of printed bytes and the origin of the print job. You can also view a log of the 20 latest print jobs that includes the user, the printing protocol and the file size. A log that displays the

accumulated usage of the connected printers allows you to control the usage of the connected printers. To delete an ongoing print job, use the delete button next to the job.

- Network Settings** From the **Network Settings** page you can set all parameters that control the network traffic to and from the Axis Network Print Server. You can enable or disable any of the supported network protocols and fine-tune the parameter settings. For additional information, see the Online Help pages.
- Support** From the **Support** page you can receive help to resolve any installation or print problems that might occur. If your problems persist, the Support page allows you to produce a Server Report. The Server Report includes the settings of the Axis Network Print Server, information about your connected printers as well as the current network settings. The Server Report is of great value for support assistance, so please mail, email or fax it to your support channel together with a detailed problem description.
- Statistics** The **Statistics** page displays information about the network traffic to and from the Axis Network Print Server as well as information about servers and services that are connected or associated with the Axis Network Print Server.
- Help** The **Help** page displays a comprehensive description of the configuration and management activities that can be performed from the internal Web pages of the Axis Network Print Server. These activities include instructions on how to install the Axis Network Print Server in various environments and how to upgrade it with new firmware. A detailed index is also available.
- Security Settings** On the **Security Settings** page you can enable or disable *SSL* (Secure Socket Layer - a protocol designed to provide secure communications on the Internet.) and *TLS* (Transport Layer Security, a protocol that guarantees privacy and data integrity between applications communicating over the Internet) You can also create secure certificates and disable/enable insecure protocols.
- Whenever *SSL/TLS* is enabled, you have to address the print server's Web interface in the secure way, i.e. via `https://`
- See *Enabling SSL via the Web Interface*, on page 121 for a detailed description.
- Parameter List** Shows all print server parameters and their current settings.
- Restart** Restarts the print server.

Software Default A Software Default will reset all print server parameters and settings to their default values **except**:

- Node address (NODE_ADDR.)
- IP Address (INT_ADDR.)
- DHCP enabled (DHCP_ENB)
- Installed certificate
- Private key

Also see *The Test Button*, on page 129 for instructions on performing a Factory Default.

Firmware Upgrade Upgrades the print server's internal software.

Using AXIS ThinWizard for Print Server Management

AXIS ThinWizard software allows you to manage and upgrade **multiple** Axis products. Using a standard Web browser, you can find, install, monitor, configure and upgrade your Axis print servers remotely in any TCP/IP network. AXIS Thin Wizard 3.0 is Windows 2000 and Windows XP compatible.

Installing AXIS ThinWizard AXIS ThinWizard software is available on www.axis.com
You should only install AXIS ThinWizard on a designated computer on your network.

To install, follow the instructions given by the Installation Wizard. During the installation, you will be asked to enter a user id and a password – these will be used when logging in to AXIS ThinWizard, so please take a note of them.

Starting AXIS ThinWizard If AXIS ThinWizard is installed on the workstation you can access its Web interface via **Start | All Programs** (using Windows XP; on Windows 2000: **Start | Programs**). If it is installed on another computer, follow the instructions below:

1. Make sure that the computer where you installed the AXIS ThinWizard is up and running on your network.
2. Start a Web browser on a client in your network.
3. Enter the IP address or the host name of the computer where you installed AXIS ThinWizard. (If the server is installed on another port than 80, you must enter the port name after the host name or the IP address).
4. The AXIS ThinWizard start page now appears in the Web browser. Enter the user id and password you specified during installation and click **Log in**.

5. The AXIS ThinWizard interface appears:

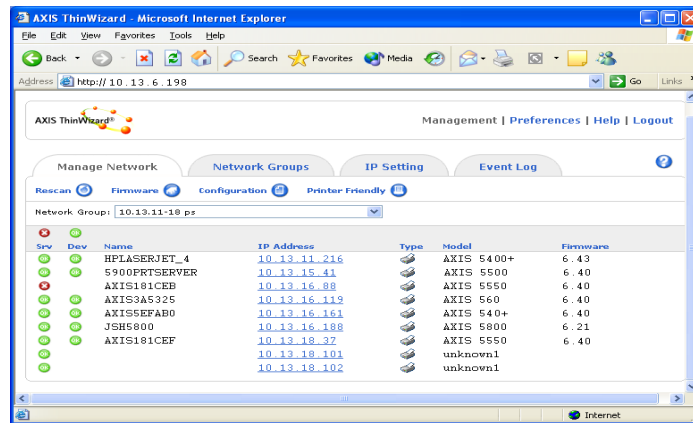
**Important!**

These parameters must be enabled in the print server's Web interface for AXIS ThinWizard to function properly:

- FTP_ENB (FTP enabled): click Admin | Network Settings | Detailed View | TCP/IP Network | FTP Enabled => Yes.
- SNMP_ENB (SNMP Enabled): click Admin | Network Settings | Detailed View | SNMP | SNMPv1 Enabled => Yes

These parameters are enabled by default in the print server.

The first time you use AXIS ThinWizard, set the Preferences to reflect your network environment:

Select a network group from the list on the Manage Network page. If the list is empty, you must first create a group. Click the Network Groups tab and follow the instructions.

Creating a Network Group in AXIS ThinWizard

The network group concept is the corner stone of AXIS ThinWizard. By dividing your network into network groups, you can monitor your print servers more efficiently. The scope of each network group is determined by the Axis server types and IP address ranges that are included. You can create as many network groups as you want.

Follow the instructions below to create a network group:

1. Click **Network Groups** in the AXIS ThinWizard main menu.
2. Click **Create**.
3. The Create Network Group page opens. Type the name of the network group, enter the IP address ranges and Axis server types that should be included. If you are only interested in managing print servers, deselect all options but the **print server** option.
4. Click **OK** to create the network group.

You can edit the properties of each network group from the Network Groups page. Simply select the network group from the list and use one of the **Edit**, **Copy** or **Remove** commands.

- Managing Print Servers** Follow the instructions below to access the AXIS 5500/AXIS 5550 using AXIS ThinWizard:
1. Click **Manage Network** in the main menu.
 2. Select the network group, including the, from the drop-down list. All AXIS servers included in the network group appear in the window.
 3. Click the link of the AXIS 5500/AXIS 5550 to access its internal Web page.
 4. The 'Srv' and 'Dev' columns show the status of your print servers and printers.

- Changing the IP Settings** Using AXIS ThinWizard you can also set or change each print server's IP parameters.
1. Click **IP Settings** in the main menu.
 2. Select print server in the list.
 3. Enter your data: IP address, Subnet mask, Default gateway and the print server's password (default password is **pass**).
 4. Click **Set** to save your settings.
 5. Click **Rescan** to update AXIS ThinWizard and see the changes.

If Your Print Server is not Shown in the List If your print server is not shown in the list, click "**Click here...**". By entering the serial number of the print server (found on the underside label) you will be able to set the print server's IP parameters.
Example: *00408c181cf0*

Upgrading Axis Servers Refer to "*Upgrading using AXIS ThinWizard*" on page 85, for more information about upgrading Axis servers using AXIS ThinWizard.

Multiple Configuration and Installation Using AXIS ThinWizard it possible to change the settings of several Axis servers simultaneously. It is also possible to copy the configuration from one server to another. This is a convenient way to install a new server, based on the settings of an already existing server.

For additional information, please refer to the AXIS ThinWizard online help.

Using FTP for Print Server Management

Having assigned an IP address to your Axis Network Print Server, as described in "*Assigning an IP Address to the Print Server*" on page 15, you can change the Axis Network Print Server parameter settings using the File Transport Protocol (FTP).

Ensure that **FTP Enabled** is set to *yes*. To check this parameter, browse to the print server and select **Admin | Network Settings | Detailed View | TCP/IP Network**.

Editing the *config* file Follow the instructions below to edit the *config* file using FTP:

1. Log in to the Axis Network Print Server by typing:
`ftp <host name> or ftp <IP address>` in a DOS window (Windows) or in a UNIX shell.
2. Enter the user id and the password. (The default entries are `root` and `pass`.)
3. Download the *config* file to your host by typing:
`get config`
4. Edit the file using your preferred text editor.
5. Save the *config* file to the Axis Network Print Server by typing:
`put config CONFIG`

Notes:

- It is important that the destination file is specified in capital letters. Otherwise the edits are temporary and will be lost once the Axis Network Print Server has been powered off.
- To edit the *config* file from a Macintosh you will need FTP support such as MacTCP, Fetch or Anarchie. The procedure for editing the file is the same as described above.

The example below describes how to upload and download the *config* file using FTP from a DOS window.

Example:

```
> ftp npserver
connected to npserver.
220 AXIS 5500 FTP Network Print Server v7.00 Sep 06
2004 ready.
Name (npserver:(none)): root
331 User name ok, need password
Password: pass (not visible)
230 User logged in
ftp> get config
200 PORT command successful.
150 Opening data connection for config
(192,168,0,10,4,64), (mode ascii).
226 Transfer complete.
ftp: 10527 bytes received in 0.22Seconds 47.85
Kbytes/sec)
ftp> put config CONFIG
200 PORT command successful.
150 Opening data connection for CONFIG
(192,168,0,10,4,65), (mode ascii).
226 Transfer complete.
10527 bytes received in 0.22Seconds 47.85 Kbytes/sec)
ftp> bye
221 Goodbye.
>
```

Viewing the *Account* File The *account* file contains data concerning the ten last print jobs. It specifies an internal job number, the user that initiated the job, the protocol and logical printer that was used, current status (Completed, Off-line, or Printing), number of bytes printed, elapsed time and off-line time.

Follow the instructions below to view the *account* file using FTP:

1. Log in to the Axis Network Print Server by typing:
`ftp <host name>` or `ftp <IP address>` in a DOS windows (Windows) or in a UNIX shell.
2. Enter the user id and the password. (The default entries are `root` and `pass`.)
3. Download the *account* file to your host by typing:
`get account`
4. View the *account* file using your preferred text editor.

Viewing the *Status* File The status command shows which printer port the logical printers are assigned to, and their current status.

Follow the instructions below to view the *status* file using FTP:

1. Log in to the Axis Network Print Server by typing:
`ftp <host name>` or `ftp <IP address>` in a DOS windows (Windows) or in a UNIX shell.
2. Enter the user id and the password. (The default entries are `root` and `pass`.)
3. Download the *status* file to your host by typing:
`get status`
4. View the status file using your preferred text editor.

FTP Help By typing `help` in step 3 in the FTP instruction sets above, a list of all available files and commands will be displayed.

Using Telnet

Having assigned an IP address to your Axis Network Print Server, as described in “*Assigning an IP Address to the Print Server*” on page 15, you can manage your Axis Network Print Server using the Telnet protocol.

Viewing the *Account* File The *account* file contains data concerning the last ten print jobs. It specifies an internal job number, the user that initiated the job, the protocol and logical printer that was used, current status (Completed, Off-line, or Printing), number of bytes printed, elapsed time and off-line time.

Follow the instructions below to view the *account* file using telnet:

1. Log in to the Axis Network Print Server by typing:
telnet <host name> OR telnet <IP address> in a DOS window (Windows) or in a UNIX shell.
2. Enter the user id and the password. (The default entries are `root` and `pass`.)
3. View the *account* file by typing:
`account`

The example below shows how to view the *account* file using Telnet from a UNIX shell.

Example:

```
> telnet npserver
Trying 192.36.253.96...
Connected to npserver.
Escape character is '^]'.

Axis Network Print Server TELNET Print Server v7.00 Sep 06 2004

Axis Network Print Server network login: root
Password: pass          (not visible)

Axis Network Print Server TELNET Print Server v7.00 Sep 06 2004

Root> account
Current account file:
JOB          USER      PROT      LPR S BYTES  ETIME  OTIME
1            Thomas    FTP        pr2 C 1885   2      0
2            Joe       LPT        pr1 C 23074  4      0
3            RICHARD  PSERVER    pr2 C 43044  5      0
4            MacUser   APPLE      pr1 C 6717   2      0
5            LSLM_user NetBIOS    pr2 C 36995  3      0
6            patrick   PROS       pr5 P 83208  9      0
Root>
```

Typical Telnet session to view the *Account* File

**Viewing
the *Status* file**

The status command shows which printer port the logical printers are assigned to, and their current status.

Follow the instructions below to view the *status* file using telnet:

1. Log in to the Axis Network Print Server by typing:
telnet <host name> OR telnet <IP address> in a DOS window (Windows) or in a UNIX shell.
2. Enter the user id and the password. (The default entries are `root` and `pass`.)
3. View the *status* file by typing:
`status`

Performing Resets Three types of reset commands allow you to perform soft resets, to perform hard resets, and to reset the print server's parameters to its default settings.

Follow the instructions below to perform a soft reset using telnet:

1. Log in to the Axis Network Print Server by typing:
`telnet <host name>` or `telnet <IP address>` in a DOS window (Windows) or in a UNIX shell.
2. Enter the user id and the password. (The default entries are `root` and `pass.`)
3. Restart the print server's protocols by typing:
`softreset`

Replace the command in step 3 above with `hardreset` or `default` to perform the other two reset operations.

Using SNMP

You can use SNMP (Simple Network Management Protocol) for remotely monitoring and configuring of the Axis Network Print Server. All major functions for print servers are supported.

General Information SNMP refers to a set of standards for network management, including a protocol, a database structure specification, and a set of data objects. The Axis Network Print Server SNMP implementation runs in the TCP/IP environment.

The management is handled by NMS (Network Management System) software running on a host on your network. The NMS software communicates with network devices by the means of messages, which are references to one or more objects.

A message can be a question or an instruction to a device, or an alarm triggered by a specific event in a device. Objects are contained in data bases called MIBs (Management Information Base), where MIB-II is a standard database.

The Axis Network Print Server supports all relevant parts of MIB-II and also includes a private enterprise MIB. Refer to *The AXIS MIB*, on page 99.

System Requirements for SNMP The following requirements must be fulfilled in order to make full use of the Axis Network Print Server SNMP support:

- NMS software that allows you to install private enterprise MIBs
- A host, supporting FTP, on which to run the NMS software

Follow these steps to add the AXIS MIB to your NMS software:

1. Log in to the Axis Network Print Server using FTP.
2. Download the MIB file */snmp/axis.mib* to the NMS host.
3. Install the AXIS MIB according to instructions in your NMS software documentation.

The AXIS MIB The AXIS MIB contains a large number of objects which may be categorized as follows:

- Menu objects - used for viewing and changing the Axis Network Print Server configuration from the NMS program. Refer to *The Parameter List*, on page 137.
- Printer status and unit administration objects - used for monitoring Axis Network Print Server print jobs and storing parameter changes permanently.
- Trap objects - used for alarms at various error conditions.

For technical details, you can view the MIB file (*axis.mib*) with any text editor.

SNMP Device Index When using the TCP/IP protocol (and if the printer driver permits), the print server can use **SNMP Status** to find out if the printer is ready to accept a new job. See “*SNMP Device Index*” on page 158.

Using Novell Utilities

After installing the Axis Network Print Server into the NetWare environment, you can manage your Axis Network Print Server, using either PCONSOLE, Novell’s NetWare Administrator, or iPrint.

NetWare Administration Some useful features provided by the NetWare Administrator are described in more detail below:

Printer Status The Printer Status menu, detailed below, shows the status of an active print job serviced by an Axis Network Print Server network print server. It displays detailed information concerning the active job including, Print Queue, print job description, size of print file, percentage of job completed, etc. You can also abort or pause the print job from this menu.

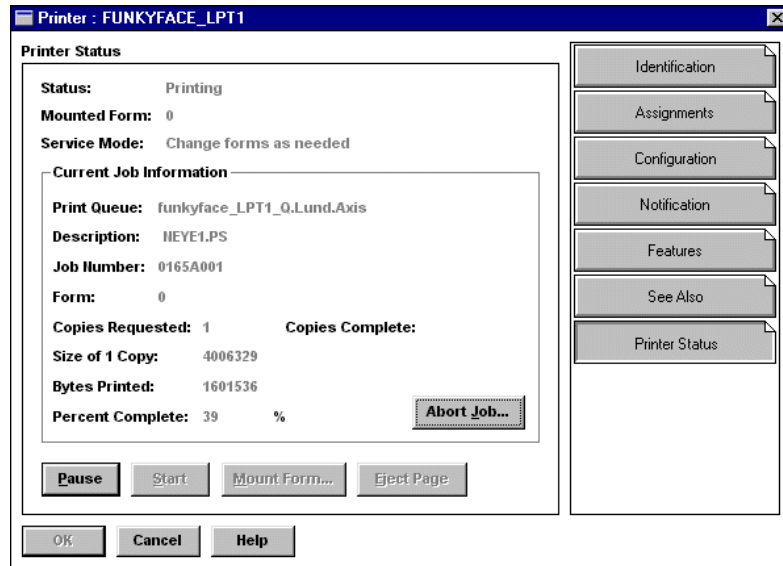

NetWare Administrator Printer Status Menu

Notification You can use the NetWare Administrator to enable or disable status notification messages for printers connected to the Axis Network Print Server, e.g. Busy, Off-line, Out of paper, Paper jam, etc. You can also add or remove print job owners and administrators from the list of persons to be notified.

Print Layout You can view installed Axis Network Print Server Network Print Servers and their relative print queues for any NetWare Organizational Unit. You can also display summary information by right-clicking on the printer object you want to examine.

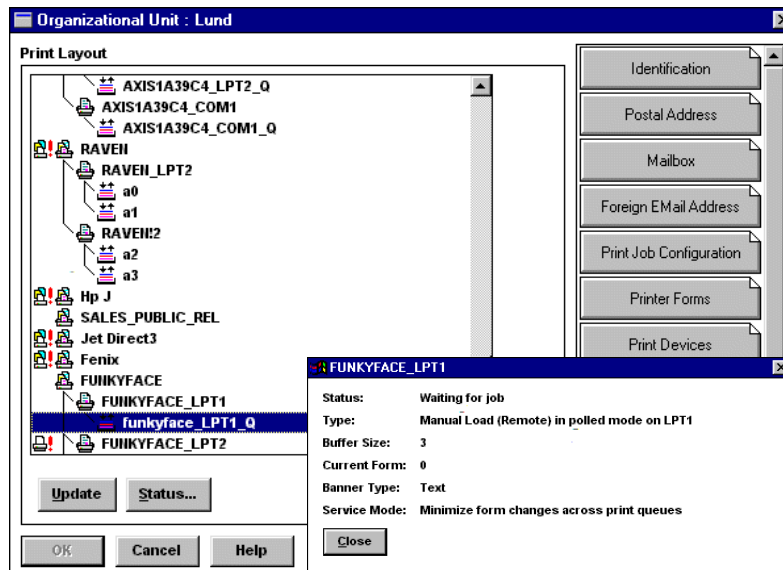

NetWare Print Layout with corresponding information summary.

Section 11 Configuration Possibilities

This section describes some special features offered by the AXIS 5500/AXIS 5550:

Autodetect Printer Type, on page 101

Auto-IP, on page 101

Changing Language in the Print Server's Web Interface, on page 119

E-mail Notification, on page 102

Enabling Secure Web Services – SSL/TLS, on page 121

Flashloading New Firmware into the Print Server, on page 119

IPP (Internet Printing Protocol), on page 102

Logical Printers for Customized Printing, on page 111

Network Speed, on page 118

NetWare Packet Signature Levels, on page 118

Overriding Port Status, on page 123

TCP/IP Restrictions, on page 120

Autodetect Printer Type

The print server can automatically detect the type of printer you are using if you enable **Autodetect Printer Type**. The print server can then recognize Epson and Hewlett Packard InkJet printers. Most Epson and Hewlett Packard InkJet printers that have Mac OS printer drivers for network printing are supported. If **Autodetect Printer Type** is disabled, the AppleTalk printer type has to be specified manually in the print server. For Epson InkJets it would be "EPSONLQ2" and for HP InkJets it would be "DeskWriter". If the print server does not recognize the connected printer the default setting, "LaserWriter" will be used as printer type. "LaserWriter" is the recommended setting to be used with all PostScript printers.

To enable **Autodetect Printer Type**, log in to your print server's Web interface and select **Admin | Network Settings | Detailed View | Macintosh | Auto Detect Printer Type | Yes**.

See the **Help** pages in the print server's Web interface for details.

Auto-IP

In the absence of an IP address management mechanism such as DHCP, the print server will receive a temporary IP address automatically over

Auto-IP, a method which enables the host to automatically take a linklocal IPv4 address. Auto-IP is supported by Windows 98, Me, 2000, XP and Mac OS version 8.5 and higher.

E-mail Notification

Whenever an event that needs human intervention occurs in a network printer, the concerned person can be notified by e-mail. This 'trouble-report' contains a short and concise description of the event. Five events are covered: **Paper Jam, Out of Paper, Toner Low, No Toner, Printer Off-line.**

In order to determine who the e-mail recipients will be of these different trouble-reports, follow these instructions:

1. From your print server's internal Web page, go to **Admin | Network Settings | Detailed View | e-mail Notification**. The following options will appear:

Options	E-mail recipient
Administrator e-mail Address	This address will be used as "Reply to"-address in the e-mails
PAPER JAM	The person responsible for handling paper jams in the printer
OUT OF PAPER	The person responsible for filling the printer with paper
TONER LOW	The person responsible for filling up the toner in the printer
NO TONER	The person responsible for changing the toner in the printer
PRINTER OFFLINE	The person responsible for the overall maintenance of printer

2. Enter the respective e-mail addresses of the trouble-report recipients in the blank fields as follows:
name@company.com
3. Click **OK** and exit when done.

Important:

Check that the **SMTP Server** and **Domain Name** parameters in the print server's internal Web pages are correct. This is done in: **Admin | Network Settings | Detailed View | TCP/IP Network**

IPP (Internet Printing Protocol)

The Axis Network Print Server enables printing over the Internet with IPP (Internet Printing Protocol), an industry standard that allows users to print to remote printers across the Internet.

With IPP, a user with an Internet connection can send a document to any printer which is connected to the Internet. IPP is platform independent and can be used to print over any LAN or WAN that supports TCP/IP.

In practical terms, this means that you can send documents to a remote printer as an addition to or replacement of fax and e-mail, with the same quality and color options of traditional network printing.

IPP clients An *IPP client* needs to be installed on your computer together with an appropriate printer driver for proper IPP functionality. The IPP client is a tool that adds destination printers to your printer list.

The Axis Network Print Server with integrated IPP is compatible with any 1.0 and 1.1 compliant IPP client.

The Axis Network Print Server presents IPP printer objects to the client, one for each printer port. Some of the most common IPP client printing methods are described below. Please refer to your IPP client documentation for more specific information.

Currently Available IPP Clients on the Market:

- For Windows 2000/XP/2003: the Microsoft IPP Client (automatically installed with the Operating System).
- For Windows 98, NT: IPP clients can be downloaded from the Microsoft Web site.
- For UNIX/Linux: CUPS (can be downloaded from the Common Unix Printing System Web site at www.cups.org).
- If you wish to print using iPrint over IPP, use AXIS IPP Gateway Configuration Snap-in for iPrint in NetWare 5.x. It is available on www.axis.com (Support | Select Software). See its read-me file for installation instructions.
- For Windows NT/2000: the Internet Printer Connection software from Hewlett Packard (can be downloaded from the Hewlett Packard Web site).

IPP Printing Requirements

Before you print to an IPP printer you need to know:

- the address of the print server.
- the brand and model of the printer in order to install the appropriate printer driver.

Address Schemes for IPP Printers

When using IPP printing, you need to know the IP address or host name of your Axis print server. IPP is a client/server type protocol which comprises two industry standards:

- the 1.0 standard, which uses an `http://` address scheme
- the 1.1 standard, which uses an `ipp://` address scheme

Example using a Host Name in the 1.0 Standard:

If "axisps" is the host name of the print server, "631" is the port number and "LPT1" is the local printer port name, then the syntax of the address scheme will be `http://axisps:631/USB1` in the 1.0 standard.

Example using an IP Address in the 1.1 Standard: If “171.16.5.218” is the IP address of the print server and “USB1” is the local printer port name, then the syntax of the address scheme will be **ipp://171.16.5.218/USB1** in the 1.1 standard.

IPP User Requirements The IPP protocol does not require any special configuration of the AXIS 5500/AXIS 5550, the IPP function is automatically activated when you install your print server. IPP is platform independent and functional in Windows (NT, 98, Me and 2000/XP), Macintosh, NetWare and UNIX/Linux.

Firewall Considerations with IPP If there are one or more firewalls between the IPP client and the server, you may have to make some changes to the firewall configuration. IPP uses TCP Port 631 for printing, so any firewalls between client and server must be configured to allow bi-directional traffic on that port. Please consult your network administrator if you think any configuration changes are necessary.

How to Print from Windows 98: Before you print to an IPP printer you will need to know:

- **the address of the print server.** The address contains the IP address or host name of the print server and the printer port name.
- **the brand and type of the printer** in order to install the appropriate printer driver.

If your destination printer does not exist in your **Printer name** list, you need to add it. Adding an IPP printer to your printer list is described below.

1. Select the IPP printer to which you want to send your document. Choose the destination printer from the **Printer name** field (in **File | Print**).
2. When you press **Print**, the print job is sent over the Internet to the AXIS 5500/AXIS 5550, which then forwards the print job to the destination printer.
3. The recipient of the print job can collect the print job at the destination
Adding an IPP Printer to your Printer List in Windows 98
 1. Install the IPP client for Windows 98 on your computer. This IPP client can be downloaded from the Microsoft Web site.
 2. Open **Start | Settings | Printers**.
 3. Choose **Add Printer**, then **Network Printer**.
 4. In the **Printer** field in the **Connect to Printers** window, write the http:// address of the destination printer.
(**Example:** http://171.16.5.218:631/USB1)
 5. Select the appropriate printer driver corresponding to the destination printer.
 6. Specify a name for the printer you wish to add to your printer list. Click **Finish**. The destination printer will be added to your printer list and you are ready to print using IPP.

How to Print from Windows NT:

Before you print to an IPP printer you will need to know:

- the address of the print server. The address contains the IP address or host name of the print server and the printer port name.
- the brand and type of the printer in order to install the appropriate printer driver.

1. First you need to select the IPP printer to which you want to send your document. Select the destination printer from your **Printer Name** list (in **File | Print | Printer Setup**).

The printer name will begin with a URL: **http://...**

If your destination printer does not exist in your **Printer Name** list, you need to add it. Adding an IPP printer to your printer list is described below.

2. When you press **Print**, the print job is sent over the Internet/WAN to the AXIS 5500/AXIS 5550, which then forwards the print job to the destination printer.
3. The recipient of the print job can collect the print job at the destination printer.

Adding an IPP Printer to your Printer List in Windows NT

1. Install the Internet Printer Connection software from Hewlett Packard (can be downloaded from the Hewlett Packard Web site) on your computer.
2. Open **Start | Settings | Printers**.
3. Choose **Add Printer**. The Add Printer Wizard will start.
4. Next, the Wizard will ask you if you want to install on **My Computer** or on a **Network print server**. Choose **My Computer** and click **Next**.

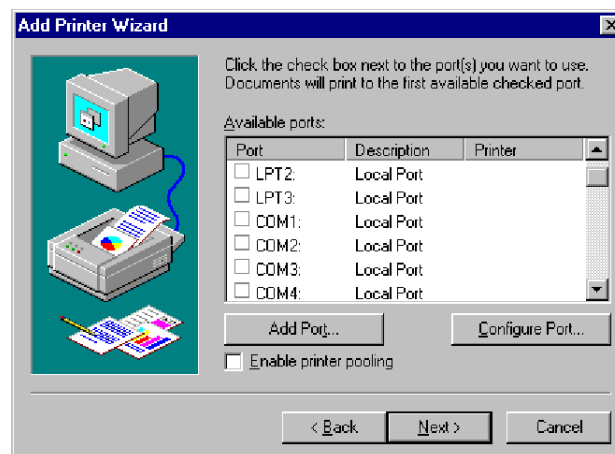

- In the Available Ports window, click **Add Port**:

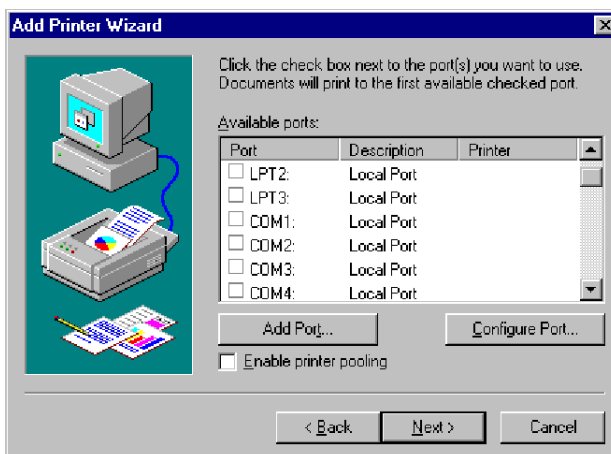

- The **Printer Ports** dialog will appear, showing a list of **Available Printer Ports**.

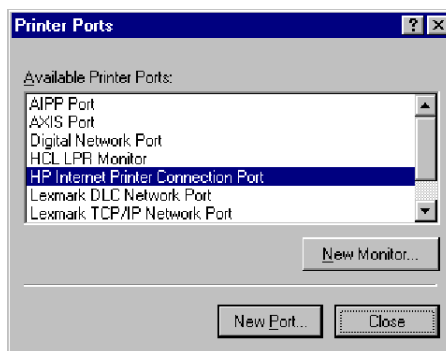

- Choose **The HP Internet Printer Connection Port** and click **New Port**.
- The **HP Internet Printer Connection** will start. Click **Next**.

- In the **IP Address, Host Name or URL** field, type the address of the AXIS 5500/AXIS 5550 to which the destination printer is connected. The URL will automatically appear in the **Port Name** field as well:

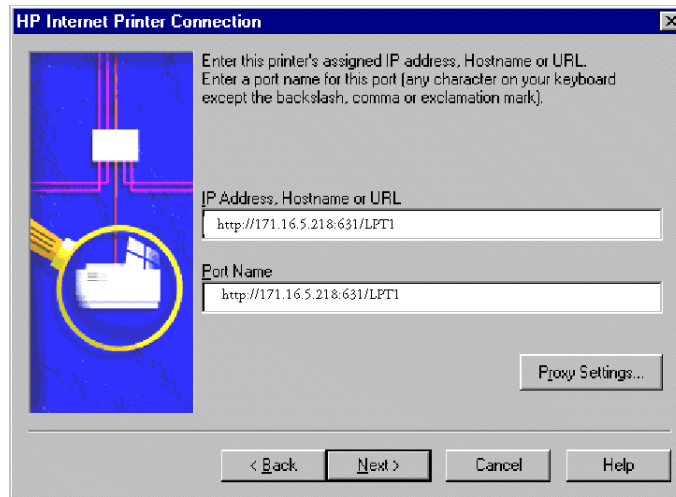

(Example: `http://171.16.5.218:631/LPT1` if you have an AXIS 5500 and want to address the parallel port or `http://171.16.5.218:631/USB1` to address the USB port.) Click **Next**.

- The Wizard will confirm the information you have entered. Click **Finish** to complete the installation and go back to the **Available Ports** list.
- The IPP printer port list is now available in the **Available Ports** list. Click **Next**.
- Next, choose a suitable driver for the destination printer and install it. Click **Next**.

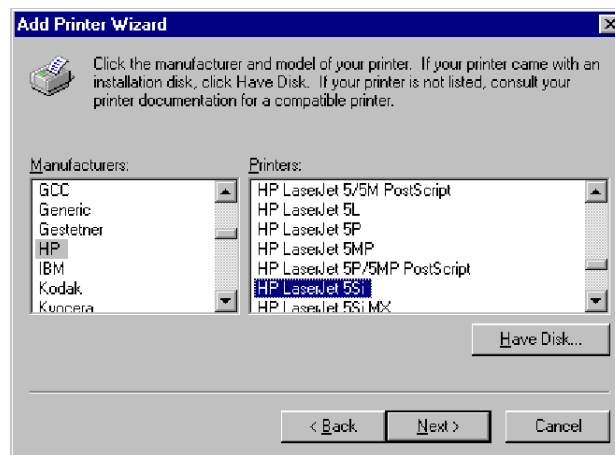

- You will be asked if you want the newly added printer to be your default printer and if you want to share the printer on your network with other users. Choose the alternatives that suit your printing needs and click **Finish** to complete the installation.

- The new printer will appear in your **Printer** window. You are now ready to start printing using IPP.

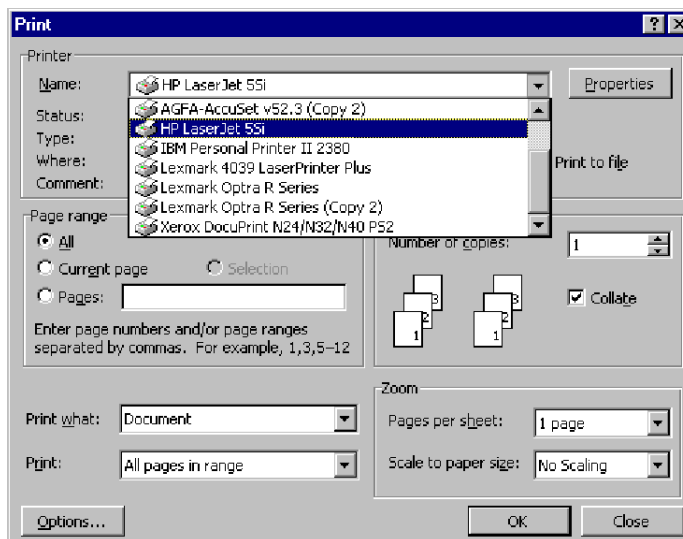

How to Print from Windows 2000/XP

Before you print to an IPP printer you will need to know:

- the address of the print server. The address contains the IP address or host name of the print server and the printer port name.
 - the brand and type of the printer in order to install the appropriate printer driver.
- Select the IPP printer to which you want to send your document. Choose the destination printer from the **Select Printer** field (in **File | Print**).

If your destination printer does not exist in your **Select Printer** list, you need to add it. Adding an IPP printer to your printer list is described below.

- When you press **Print**, the print job is sent over the Internet to the AXIS 5500/AXIS 5550, which then forwards the print job to the destination printer.
- The recipient of the print job can collect the print job at the destination printer.

Adding an IPP Printer to your Printer List in Windows 2000/XP

- Choose **File | Print** from the document you wish to print.
- In the **Select Printer** field, click the **Add Printer** icon. The **Add Printer Wizard** will start. Click **Next**.
- The Wizard will ask you if you want to install a local printer or a network printer. Choose **Network Printer** and click **Next**.

4. Enter the printer address in the URL field.

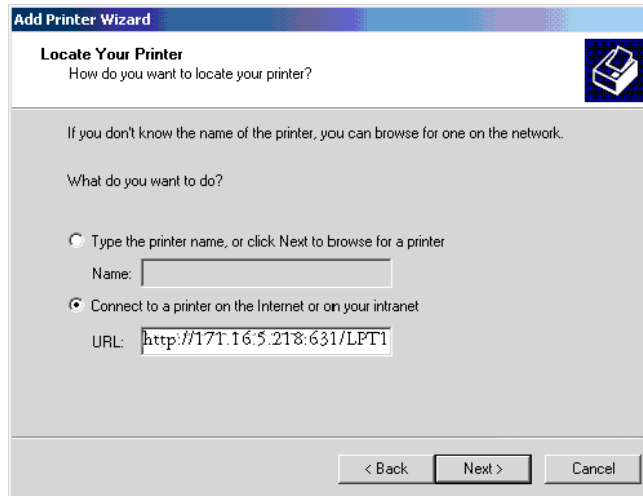

(Example: `http://171.16.5.218:631/LPT1` if you have an AXIS 5500 and want to address the parallel port or `http://171.16.5.218:631/USB1` to address the USB port.) Click **Next**.

5. If you do not have a driver corresponding to the destination printer installed on your computer, the Wizard will prompt you to install one. Click **OK**.
6. The Installation Wizard will ask you to select a printer driver corresponding to the destination printer. Select the printer driver from the list and click **OK**.

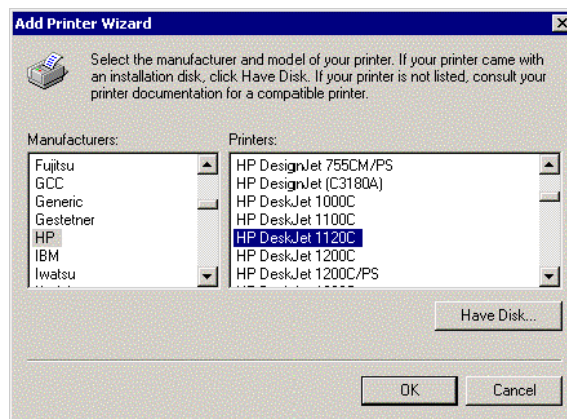

7. The Wizard will ask you if you want the printer to be your default destination printer. Make your choice and click **Next** to complete the Add Printer Wizard installation.

8. The new printer is added to your **Select Printer** window:

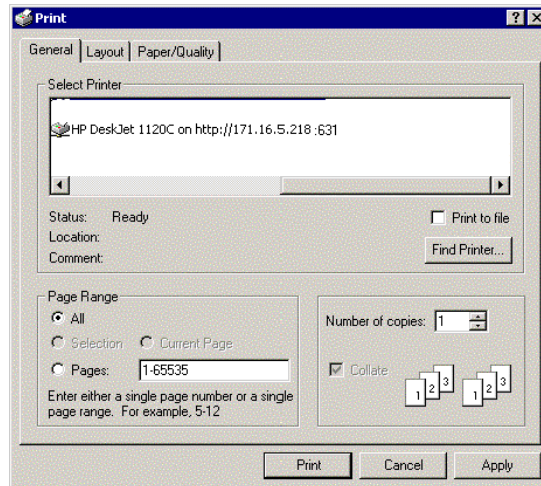

9. You are now ready to print using IPP: specify your new destination printer from the printer list and click **Print**.

Logical Printers for Customized Printing

The AXIS 5500/AXIS 5550 has a powerful facility for altering the print data. This means that your desired print format can be realized on any type of printer. The following actions can be invoked from the print server:

- The character set can be changed to suit the printer
- Strings can be added before and after the print data
- Strings within the print data can be substituted
- ASCII to PostScript conversion
- Redirection of print data to another printer if the printer is busy
- Hex Dump mode to assist with printing problems

If any of these actions are required, a Logical Printer is used to change the print data before being sent to the printer port. There are eight logical printers (PR1–PR8) that can be set up to filter the print data.

The default logical printers settings are such that PR1–PR4 cause no change to the flow of print data, while PR5–PR8 add CR to LF control characters:

<i>Logical Printer</i>	<i>Changes to data</i>
PR1	no change
PR2	no change
PR3	no change
PR4	no change
PR5	add CR to LF
PR6	add CR to LF
PR7	add CR to LF
PR8	add CR to LF

Each logical printer can be set via the print server's internal Web pages: Open a Web browser, enter the IP address of the print server in the Location/Address field and select **Admin | Logical Printers**.

The logical printers can also be set up by editing the *config* file. See “*Editing the config file*” on page 95.

Notes:

- The examples in this section describe how you can configure the available logical printers using a standard Web browser. If you want to set them directly by editing the *config* file, just enter the values for the corresponding parameters.
- The examples should only be viewed as suggestions how to configure the logical printers. You should, of course, configure them according to the needs of your network.
- In the Parameter List chapter of this manual, you can find a complete list of the AXIS 5500/AXIS 5550 parameters.

Character Set Conversion A common problem in a multiple host environment is that different hosts use different ASCII character sets. As a result of this, language specific characters (such as å ü ô ñ) are sometimes printed incorrectly.

The AXIS 5500/AXIS 5550 solution to this problem is to assign a character set conversion filter to a logical printer, and then link that logical printer to the host causing the problem.

You select your desired conversion filter by setting the **Character Set Conversion (PRx_CSET.)** parameter. The output from the conversion filter is always IBM PC Set 2 (Code Page 437), and this is the character set the printer must be set up for.

Example:

Your network contains a host using the character set ISO 8859-2 and a host using the character set DEC.

In order to direct print jobs to the printer connected to the AXIS 5500/AXIS 5550, you should assign the host to a separate logical printer, and install a character set conversion filter.

Follow the instructions below to change the conversion filter:

1. From the print server's internal Web page, select **Admin | Logical Printers**.
2. Select the **PR1** tab.
3. Set the parameter **Physical Port** to **USB1**.
4. Set the parameter **Character Set Conversion** to **ISO>IBM**.
5. Click the **OK** button.
6. Select the **PR2** tab.
7. Set the parameter **Physical Port** to **USB1**.
8. Set the parameter **Character Set Conversion** to **DEC>IBM**.
9. Click the **OK** button.

The ISO 8859-2 printer data that is sent to logical printer PR1 converts to IBM PC Set 2 and is printed on USB1. Similarly, the DEC printer data that is sent to logical printer PR2 converts to IBM PC Set 2 and is printed on USB1.

Adding Strings Before and After Print Jobs

These string functions provide a way to send printer control commands before and after each print job. They may be specified individually for each logical printer.

All strings are entered as hexadecimal byte values.

Example:

Assume that the logical printer PR5 is configured as a PostScript printer and that you want to append the PostScript End of File character (hex 04) after each print job.

Follow the instructions below to add a string after the print job:

1. From the print server's internal Web page, select **Admin | Logical Printers**.
2. Select the **PR5** tab.
3. Enter the string **04** in the **String After Print Job** text field.
4. Click the **OK** button.

Example:

You have an HP LaserJet printer with dual trays, and want to print on pre-printed forms when using the logical printer PR4. The standard forms are taken from the lower tray, and the pre-printed forms are taken from the upper tray. The string before print job should contain the command to select the upper tray: $\text{^E}_C\&11H$ (hex 1B 26 6C 31 48). The string after print job should contain the command to select the lower tray: $\text{^E}_C\&14H$ (hex 1B 26 6C 34 48).

Follow the instructions below to add strings before and after the print job:

1. From the print server's internal Web page, select **Admin | Logical Printers**.
2. Select the **PR4** tab.
3. Enter the string **1B 26 6C 31 48** in the **String Before Print Job** text field.
4. Enter the string **1B 26 6C 34 48** in the **String After Print Job** text field.
5. Click the **OK** button.

String Substitutions The string substitution function performs search and replace operations on the print data. The primary application is to replace printer control commands. Up to twenty string substitutions may be specified individually for each logical printer.

All strings must be entered as hexadecimal byte values, and each match and substitute string must be preceded by a count byte.

You substitute command strings by editing the String Substitutions (PR_x_STR.) parameter.

Example:

Assume that you want to replace the UNIX/Linux New Line (hex 0A) with an Carriage Return/Line Feed (hex 0D 0A) for logical printer PR1.

Follow the instructions below to substitute command strings:

1. From the print server's internal Web page, select **Admin | Logical Printers**.
2. Select the **PR1** Web page.
3. Enter the string **01 0A 02 0D 0A** in the **String Substitutions** text field.

<i>Hex Code</i>	<i>Explanation</i>
01	length of the string you want to replace
0A	the string you want to replace
02	length of the substitute string
0D 0A	the substitute string

4. Click the **OK** button.

This conversion is the default setting for logical printers PR5 through PR8.

Example:

Assume that you want to replace the UNIX/Linux New Line (hex 0A) with an Carriage Return/Line Feed (hex 0D 0A), and the printer command $\text{E}_C\text{G}1$ (hex 1B 47 31) with E_CY (hex 1B 59) for logical printer PR2.

Follow the instructions below to substitute command strings:

1. From the print server's internal Web page, select **Admin | Logical Printers**.
2. Select the **PR2** tab.
3. Enter the string **01 0A 02 0D 0A 03 1B 47 31 02 1B 59** in the **String Substitutions** text field.

<i>Hex code</i>	<i>Explanation</i>
01	length of the UNIX/Linux New Line command
0A	the UNIX/Linux New Line command
02	length of the Carriage Return/Line Feed command
0D 0A	the Carriage Return/Line Feed command
03	length of the printer command to replace
1B 47 31	the printer command to replace
02	length of the new printer command
1B 59	the new printer command

Click the **OK** button.

Note:

Extensive use of string substitutions will naturally decrease the throughput rate of the AXIS 5500/AXIS 5550.

ASCII to Postscript Conversion The AXIS 5500/AXIS 5550 logical printers can translate ASCII print data into PostScript format. This makes it possible to print on a PostScript printer from a host that does not support PostScript. The conversion is selected by activating a filter that converts ASCII data into Postscript. This filter can be activated individually for each logical printer.

Activate your desired filter by setting the Printer Language Translation (PRx_FILT.) parameter.

Example: Follow the instructions below to convert ASCII print data to PostScript for logical printer PR2:

1. From the print server's internal Web page, select **Admin | Logical Printers**.
2. Select the **PR2** tab.
3. Set the **Printer Language Translation** parameter to **POSTSCR**.
4. Click the **OK** button.

If you select the parameter value **AUTO_PS**, the print data for every print job is searched and if any ASCII data is found, it is translated into PostScript. This setting is recommended if you are not sure if the print data is ASCII or PostScript.

PostScript Settings When a logical printer is set for PostScript conversion, you must specify the following:

- page size
- page orientation
- page format
- which font to use

The default page size is A4 and the default page orientation is Portrait, while the page format parameters are as follows:

<i>Page Format Parameter</i>	<i>Default Value</i>	<i>Comment</i>
Lines per page (MPL)	66	
Characters per line (MPP)	0	0 = disable line wrap
Characters per inch (CPI)	100	100 = 10 char per inch
Lines per inch (LPI)	60	60 = 6 lines per inch
Left margin (LM)	30	30 = 3.0 mm
Top margin (TM)	50	50 = 5.0 mm

The PostScript font can be any font that is installed in the printer. If no font is specified, Courier will be used.

Example: Follow the instructions below to set the PostScript parameters for logical printer PR2:

1. From the print server's internal Web page, select **Admin | Logical Printers**.
2. Select the **PR2** tab.
3. Set the **Printer Language Translation** parameter to **POSTSCR**.

4. Set the **PostScript Page Size** parameter to **LETTER**.
5. Set the **PostScript Page Orientation** parameter to **LANDS**.
6. Enter the string **48 0 120 60 30 50** in the **PostScript Page Format** text field.

<i>Hex code</i>	<i>Explanation</i>
48	48 lines per page
0	disable line wrap
120	120 = 12 characters per inch
60	60 = 6 lines per inch
30	30 = 3 mm left margin
50	50 = 5 mm top margin

7. Enter the string **Helvetica** in the **PostScript Font** text field.
8. Click the **OK** button.

Redirecting Print Jobs when a Printer is Busy

If print data is received for a printer that is already busy, the host normally must wait. However, if you have an AXIS 5500 it is possible to use a logical printer to redirect the print data to another logical printer when the target printer is busy. If the second printer is also busy, the host must wait until the target printer is ready.

Example: Follow the instructions below to redirect PR1 print jobs to PR3, when the printer assigned to PR1 is busy:

1. From the print server's internal Web page, select **Admin | Logical Printers**.
2. Select the **PR1** tab.
3. Set the **Physical Port** parameter to **USB1**.
1. Set the **Secondary Printer** parameter to **PR3**.
2. Set the **Wait On Busy** parameter to **NO**.
3. Click the **OK** button.
4. Select **Admin | Logical Printers** and the **PR3** tab.
5. Set the **Physical Port** parameter to **LPT1**.
6. Click the **OK** button.

Notes:

- The two printers must use the same printer driver.
- Logical Printer redirection cannot be nested. If PR3 is redirected to another logical printer, the print job will not be redirected if PR3 is busy.
- If both printers are busy, the print job will be printed on the printer that first finishes its active print job.

Read Back of information The AXIS 5500/AXIS 5550 supports bi-directional printing. The information from the printer is read back on the parallel port when the parameter Read Back Port (PRx_IN.) has the default setting of AUTO. However, it is required that the printer also supports bi-directional printing.

Please refer to your printer documentation for further details regarding bi-directional printing support.

Example: Follow the instructions below to disable the bi-directional communication for logical printer PR1:

1. From the print server's internal Web page, select **Admin | Logical Printers**.
2. Select the **PR1** tab.
3. Set the **Read Back Port** parameter to **NONE**.
4. Click the **OK** button.

Debugging using the Hex Dump Mode When hex dump mode is enabled, the print data is printed as hexadecimal byte values rather than characters; printer control commands are also printed as hex values. This allows you to inspect what control and print characters are actually being sent to the printer, which is a useful debugging facility for more difficult printing problems.

Example: Follow the instructions below to enable the hex dump mode for PR3:

1. From the print server's internal Web page, select **Admin | Logical Printers**.
2. Select the **PR3** tab.
3. Set the **Hex Dump Mode Enabled** radio button to **YES**.
4. Click **OK**.

Note:

The page length for hex dump printouts is determined by the lines per page value of the PostScript page format parameter.

Network Speed

With the Network Speed parameter you can manually specify the speed at which you will send and receive network packages. You can change the Network Speed setting to correspond to the type of network you are using (10 or 100 Mbit).

To change the Network Speed in an Ethernet network, log in to the print server's internal Web pages and click **Admin | General Settings => Change**.

You have the options listed here:

<i>Network Speed</i>	<i>Comment</i>
AUTO_SENSE	This is the default value where the print server detects which speed is optimal for each network package you transfer.
10_HALF_DX	10 Half Duplex
10_FULL_DX	10 Full Duplex
100_HALF_DX	100 Half Duplex
100_FULL_DX	100 Full Duplex

The default Network Speed value is AUTO_SENSE, which is the correct option for the majority of users.

If you choose a faulty Network Speed option for your network, you may lose contact with the print server.

To reset the Network Speed parameter to AUTO_SENSE, you will have to reboot the print server (disconnect and then re-connect the external power supply).

NetWare Packet Signature Levels

NetWare Packet Signatures protect servers and clients using the NCP (NetWare Core Protocol) services and prevent packet forgery by requiring the server and the client to sign each NCP packet.

There are two levels of NCP Packet Signature: the Server Level and the AXIS Print Server Level (also known as the Workstation Level).

Server Levels

Server packet signature levels are assigned by a new SET parameter:
SET NCP PACKET SIGNATURE OPTION = *n*

Key to Server Levels	Explanation
0	Server does not sign packets (regardless of the print server level)
1 (default)	Server signs packets only if the print server requests it (print server level is 2 or higher)
2	Server signs packets if the print server is capable of signing (print server level is 1 or higher)
3	Server signs packets and requires the print server to sign packets (or logging in will fail)

Print Server Levels Print server signature levels are assigned by a new NET.CFG parameter SIGNATURE LEVEL = *n*

Key to Print Server Levels	Explanation
0	Print server does not sign packets
1 (default)	Print server signs packets only if the server requests it (server option is 2 or higher)
2	Print server signs packets if the server is capable of signing (server option is 1 or higher)
3	Print server signs packets and requires the server to sign packets (or logging in will fail)

Regardless of server level, the AXIS print server has the capability to log in in Print Server Mode since it supports NCP Packet Level 3 (which is the most restrictive).

These procedures are taken care of automatically. There are no configurable parameters in the Print Server for choosing the NCP Packet Signature Level. The AXIS print server adapts itself to the Server Level.

Flashloading New Firmware into the Print Server

The firmware can easily be upgraded, since flash loading is possible from the print server's internal Web pages. Client software is not needed to upgrade the firmware. See *Upgrading from the Print Server's Internal Web Pages*, on page 85.

Changing Language in the Print Server's Web Interface

English, French, German, Italian, Japanese and Spanish is supported in the print server's Web interface, with English as the default language. You can change the language used for the print server's Web interface from the User mode:

1. Click the **Change** button next to 'Language'.
2. Choose your preferred language and character set from the drop-down lists, click OK and then press F5 to refresh the view.

You can change the **Character Set** by clicking the **Change** button. The default Character Set is **ISO-8859-1**, which can be applied in most cases. Japanese requires SHIFT_JIS.

TCP/IP Restrictions

In a new and unconfigured Axis Network Print Server any user is allowed to send TCP/IP print jobs. Using a restriction list you can reject TCP/IP printing from specified IP addresses.

Enabling TCP/IP Restrictions In the print server's Web interface, select **Admin | Network Settings | Detailed View | TCP/IP Printing**.

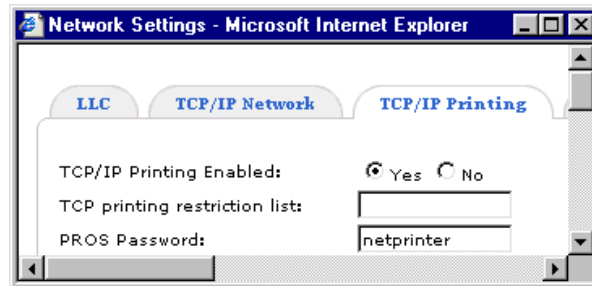

Print jobs from IP addresses specified in the **TCP printing restriction list** will be rejected. Comma delimited IP addresses as well as ranges of IP addresses can be entered.

Examples:

192.168.0.10 will reject print jobs from IP address 192.168.0.10.

192.168.0.12, 192.168.0.32 will reject print jobs from IP addresses 192.168.0.12 and 192.168.0.32.

192.168.0.40-192.168.0.79 will reject print jobs from IP addresses within the range 192.168.0.40 – 192.168.0.79.

Disabling TCP/IP Restrictions Empty the **TCP printing restriction list** to remove the restrictions. This is the default setting.

Enabling Secure Web Services – SSL/TLS

In a new and unconfigured AXIS 5500/AXIS 5550, SSL/TLS is **disabled**.

Certificates To use SSL/TLS you have to create or obtain a digital certificate. There are two kinds of certificates: self-signed certificates and third party certificates.

- Self-signed certificates are less secure but normally they are sufficiently secure for small networks with no public access. You generate such a certificate yourself and there are no fees to pay.
- For large networks and for networks with public access, third party certificates from a trusted source are normally used. You obtain them for a yearly fee from a Certificate Authority (CA).

Among other things, a certificate gives information about which domain it is issued for, its validity and the name of issuer. With SSL/TLS enabled, the installed certificate authenticates the print server to the client and all information exchanged between them will be encrypted.

Enabling SSL via the Web Interface You enable the print server's secure Web services through its internal Web pages. If you have a valid certificate loaded, select **Admin | Network Settings | Detailed View | TCP/IP Network** and set the **HTTPS Enabled** parameter to **Yes**.

If you do not have a valid certificate loaded, select **Admin | Security Settings** and click **Create**.

Decide whether you want to generate a self-signed certificate or if you want to generate a certificate request.

Generating a Self-Signed Certificate Select the **Generate Self-Signed Certificate** radio button and click **Next**. Enter the data asked for:

- Country Name: *Example:* US
- State or Province Name: *Example:* California
- Locality Name: *Example:* Los Angeles
- Organization Name: *Example:* Printers Inc
- Organizational Unit Name: *Example:* Sales Dept
- Common Name*: *Example:* printserver2@company.com
- Current Date (yyyy/mm/dd): *Example:* 2004/09/28
- Validity Duration (in days): *Example:* 365

* Common Name denotes the name given to the print server in the network. If you do not have a DNS server on your network, you must include the domain name, e. g. xxx@company.com

Click **Finish** and the print server will generate a public/private key pair as well as the self-signed certificate itself (this process will take a few minutes) and store these data in the print server. When the certificate is generated, the print server automatically loads it into your present

browser session. The browser reports the new state by changing into https mode. In the browser's Security Alert box, select **View Certificate** and **Install Certificate**. Follow the instructions of the Install Certificate Wizard.

Generating a Certificate Request

Select the **Generate Certificate Request** radio button and click **Next**.

Enter the data asked for:

- Country Name: *Example:* US
- State or Province Name: *Example:* California
- Locality Name: *Example:* Los Angeles
- Organization Name: *Example:* Printers Inc
- Organizational Unit Name: *Example:* Sales Dept
- Common Name*: *Example:* printserver2@company.com
- Current Date (yyyy/mm/dd): *Example:* 2004/09/28
- Validity Duration (in days): *Example:* 365

* Common Name denotes the name given to the print server in the network. If you do not have a DNS server on your network, you must include the domain name, e. g. xxx@company.com

Click **Finish**.

Now the print server will generate a public/private key pair and a PEM-encoded Certificate Request, called *cert.pem*. Click **Save**, **Save this file to disk** and **Save**.

Send this Certificate Request to your Certificate Authority for their signature.

Importing a Certificate

When you receive the PEM-encoded certificate from your Certificate Authority, open the print server's Web interface and select **Admin | Security Settings**. Click **Import** and follow the instructions on the screen.

Accessing the Print Server's Web Pages over https://

Whenever SSL/TLS is enabled, you can only reach the print server's Web interface through the secure services. The unsecure way via http:// is closed and now you have to address the print server's Web interface in the secure way, i.e. via https://.

- Disabling Protocols** To further increase security, you must disable protocols that are considered insecure;
- FTP (also used by AXIS ThinWizard, if FTP is disabled, AXIS ThinWizard can not function properly.)
 - Telnet
 - Auto-IP
 - DHCP
 - BOOTP
 - Remote Config (used by AXIS NetPilot)
 - SNMP Configuration (also used by AXIS ThinWizard. Note that if SNMP is disabled, AXIS ThinWizard can not function properly.)

To disable these protocols, go to **Admin | Security Settings | Protocol Settings | Detailed View** and mark the check boxes. Click **OK** to finish. *Only enabled protocols will be visible from this view!*

To enable these protocols, select **Admin | Network Settings | Detailed View | TCP/IP Network** for FTP, Telnet, Auto-IP, DHCP and BOOTP. Remote Config is enabled via **Admin | General Settings | RConfig Support**.

Important:

To ensure maximum security, it is highly recommended that you change your Administrator password after generating a certificate and disabling insecure protocols! This is done from **Admin | General Settings | Change => | General | Root Password**.

- Checking SSL/TLS Status** To check SSL/TLS status, open the print server's Web interface and select **Admin | Network Settings | Detailed View | TCP/IP Network** to see if the **HTTPS Enabled** parameter is set to Yes or No.
- To View a Certificate** To view a Certificate, open the print server's Web interface, select **Admin | Security Settings** and click **View** next to the Certificate.
- To Delete a Certificate** To delete a Certificate, open the print server's Web interface, select **Admin | Security Settings** and click **Delete** next to the Certificate.

Overriding Port Status

Some USB printers do not deliver correct port status to the print server (for instance always reporting printer off-line even if the printer is on-line). If you set the **Override Portstatus** parameter to **Yes**, the print server will ignore the port status. To set this parameter, select **Admin | General Settings | USB1** from the print server's Web interface.

Enabling the SNMPv3 Protocol

Invoke the print server's Web interface to enable the SNMPv3 protocol.

1. Select **Admin | Network Settings | Detailed View | TCP/IP Network** and ensure that **HTTPS Enabled** is set to **yes** to guarantee a secure configuration.

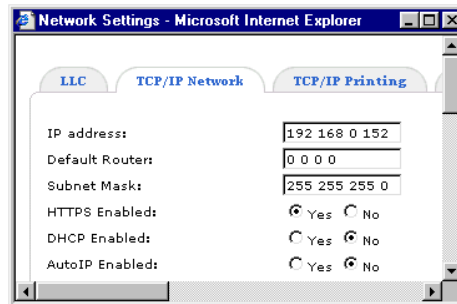

Note: You must have a valid certificate loaded to be able to enable HTTPS. See "Enabling SSL via the Web Interface" on page 121.

2. Select **Admin | Network Settings | Detailed View | SNMP** and set **SNMPv3 Enabled** to **yes**.

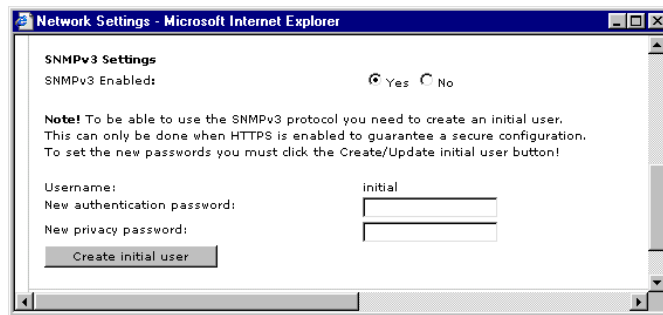

3. Create an **initial user** by entering two new passwords: one authentication password and one privacy password. Each password must consist of at least 8 characters.
4. Click the **Create initial user** button.

Now your print server is ready to accept communication according to the SNMPv3 protocol. For further management you will need an SNMPv3 management application; you use this application to configure the print server, to create new user accounts and to control access to it. Also see "Using SNMP" on page 98.

To Update the Initial User

To update the initial user, select **Admin | Network Settings | Detailed View | SNMP**, enter the two passwords (one for authentication and one for privacy) and click the **Update initial user** button.

Section 12 IP Addressing

IP Address and Subnet Mask	<p>The print server must be correctly configured with the following information to function properly:</p> <ul style="list-style-type: none">• an IP address• a subnet mask• a default gateway (or router)
IP Address	<p>Each device on your network must have a unique IP address to operate correctly. An IP address identifies the address of the device to which data is being sent and the address of the destination network. IP addresses have the format n.n.n.x where n is a decimal number between 0 and 255 and x is a number between 1 and 254 inclusive.</p>
Subnet Mask	<p>In addition to the IP address, you need to set a subnet mask. All networks are divided into smaller sub-networks and a subnet mask is a number that enables a device to identify the sub-network to which it is connected. For your network to work correctly, all devices on the subnet must have:</p> <ul style="list-style-type: none">• The same sub-network address• The same subnet mask <p>The only value that will be different is the specific host device number. This value must always be unique. The size of the network determines the structure of the IP addresses in it.</p>
Default Gateway	<p>In a network using subnets, the router that forwards traffic to a destination outside of the subnet of the transmitting device. If there is a server or a router which functions as a gateway, enter the IP address of the server or the router.</p>
IP Address and Subnet Mask Structures	<p>Two of the most common types of IP address and subnet mask structures are described here:</p> <p>Type One</p> <p>In a small (Class C) network, the IP address example '192.168.3.191' is split into two parts:</p> <ul style="list-style-type: none">• Part one ('192.168.3') identifies the network on which the device resides.• Part two ('.191') identifies the device within the network. <p>This type of IP Address generally operates on a subnet mask of '255.255.255.0'.</p>

Type Two

In larger (Class B) networks, where there are more devices, the IP address of '162.168.3.191' is split into two parts but is structured differently:

- Part one ('162.168') identifies the network on which the device resides.
- Part two ('.3.191') identifies the device within the network.

This type of IP address operates on a subnet mask of '255.255.0.0'.

Default Gateway Examples

1. This example shows a network with:

- one computer
- one networked printer
- no router

<i>Device</i>	<i>IP address</i>	<i>Subnet Mask</i>	<i>Default Gateway</i>
print server	192.168.3.191	255.255.255.0	*
pc1	192.168.3.192	255.255.255.0	*

** When no router is present on the network, the default gateway can be left undefined.*

2. This example shows a network with:

- one computer
- one networked printer
- a router with an IP address of 192.168.3.1

<i>Device</i>	<i>IP address</i>	<i>Subnet Mask</i>	<i>Default Gateway</i>
print server	192.168.3.191	255.255.255.0	192.168.3.1
pc1	192.168.3.192	255.255.255.0	192.168.3.1

Obtaining an IP Address and Subnet Mask

There are three different ways to obtain an IP address and subnet mask. These are:

- Dynamic Host Configuration Protocol (DHCP) Addressing
- Static Addressing
- Automatic Addressing (Auto-IP Addressing)

DHCP Addressing

If your network contains a DHCP server, print servers on your network will obtain an IP address and subnet mask automatically. DHCP assigns a temporary IP address and subnet mask which gets reallocated once you disconnect from the network. DHCP will work on any client Operating System such as Windows 95, 98 NT. Also, using DHCP means that the same IP address and subnet mask will never be duplicated for devices on the network. DHCP is particularly useful for networks with large numbers of users on them.

Static Addressing

With this method you must enter an IP Address and the subnet mask manually on every device. Using a static IP and subnet mask means the address is permanently fixed.

Auto-IP Addressing Network devices use automatic IP addressing if they are configured to acquire an address using DHCP but are unable to contact a DHCP server. Automatic IP addressing is a scheme where devices allocate themselves an IP address at random from the industry standard subnet of 169.254.x.x (with a subnet mask of 255.255.0.0). If two devices allocate themselves the same address, the conflict is detected and one of the devices allocates itself a new address.

Automatic IP addressing support was introduced by Microsoft in the Windows 98 operating system and is also supported in Windows 2000/XP/2003.

Registering and Resolving Host Names In order to register the host name of the print server in networks with dynamic IP address settings, WINS (Windows Internet Name Service) and DDNS (Dynamic Domain Name System) are supported. It is recommended that at least one of these methods should be used if you are setting the IP address of the print server using DHCP.

The host name of the print server is specified by the PS_NAME parameter. Refer to the *“The Parameter List”* on page 137.

WINS Host Name Rules WINS only supports 15 character long host names. If your host name is longer than 15 characters, the print server truncates the host name to 15 characters when registering with a WINS server. You can view the print server’s host name that is registered at a WINS server in the print server’s Web interface. Refer to *“Using a Web browser for Print Server Management”* on page 88.

DDNS Host Name Rules DDNS supports 47 character long host names and can only consist of the characters ‘A-Z’, ‘a-z’, ‘0-9’ and ‘-’. If your host name consists of any other characters, they are converted to ‘-’ when registering with a DDNS server. You can view which host name that is registered at a DDNS server in the print server’s Web interface. Refer to *“Using a Web browser for Print Server Management”* on page 88.

If the host name matches another entry in the DDNS data base, the print server deletes that entry before registering.

Notes:

- The default host name of the print server is 'AXIS' followed by the last 6 digits in the serial number. e.g. AXIS181636. The host name (Print server name) can be changed in the PS_NAME field on the Admin | General Settings page.
- The host name limitations conclude that if you want to register the same host name at a WINS server and a DDNS server, the host name should be no longer than 15 characters and it should only contain the characters 'A-Z', 'a-z', '0-9' and '-'.
- Refer to your system manuals or to your network administrator for instructions on how host name resolutions are performed on your system.

Setting the IP Address using DHCP

Follow the instructions below to download the IP address using DHCP:

1. Edit or create a scope in the DHCP manager of the DHCP daemon. The entries included in this scope should contain the following parameters:
 - range of IP addresses
 - subnet mask
 - default router IP address
 - WINS server IP address(es) or DDNS server IP address(es)
 - lease duration
2. Activate the scope. The print server automatically downloads the DHCP parameters. If you are using WINS or DNS, you should include at least one WINS or DNS server IP address in the DHCP scope. Immediately after the IP address has been received, the print server registers its host name and IP address on the WINS alternatively DNS server. Refer to *"Registering and Resolving Host Names"* on page 127 for more information. The print server can automatically download a customized *config* file from a TFTP server. Just add the name of the config file and the TFTP server's IP address to your DHCP scope. The *config* file is downloaded immediately after the print server receives its IP address.
3. You have now successfully set the IP address of your print server.

Note:

You have to restart the print server to download the IP address.
--

Section 13 The Test Button

The test button is located on the front right hand side of the AXIS 5500/AXIS 5550 and is used for:

- Printing a test page to check the connection to the printer.
- Printing a parameter list to see the print server's current settings.
- Performing a Factory Default of the print server.

If you want to change any of the parameters, use one of the methods described in *Section 10 Management and Configuration*, on page 88.

Printing a Test Page Press the test button **once** to print a test page. The test page contains basic information about the AXIS 5500/AXIS 5550. It is recommended that you print a test page every time you connect the print server to a printer.

Note:

AXIS 5550 has two printer ports. If just one of ports is connected to a printer, the test page will be printed on that port. If each port is connected to a printer, the default setting will send the test page to the parallel printer. The default behavior can be changed from the print server's internal Web pages under **Admin | General Settings => Change**.

Printing the Parameter List Press the test button **twice** to print a parameter list showing the current AXIS 5500/AXIS 5550 settings. This list provides comprehensive details of all the parameters and their current status. Refer to *Section 16 The Parameter List*, on page 137.

Performing a Factory Default

1. Remove the external power supply to switch off the print server.
2. Press and hold down the test button while you reconnect the external power supply.
3. Continue to hold down the test button until the network indicator remains constantly lit. This should take about 20 seconds.
4. Restart the print server by disconnecting and reconnecting the external power supply.

Important:

A factory default will reset all print server parameters and settings to their default values, except

- installed certificate
- private key

Section 14 Troubleshooting

This section provides useful information to help you resolve difficulties you might have with your AXIS 5500/AXIS 5550. Fault symptoms, possible causes and remedial actions are provided within a quick reference table.

Please visit the Axis Web site for latest troubleshooting tips, more support and additional help through the FAQ database or to fill in and submit a Support question.

General The USB port in an AXIS 5500 / AXIS 5550 supports USB printers only. If any other USB device has been connected to this port, the print server must be restarted before it can function properly again.

Overriding Port Status Some USB printers do not deliver correct port status to the print server (for instance always reporting printer off-line even if the printer is on-line). To override this, see *“Overriding Port Status”* on page 123.

LED Indicators

<i>Indicator</i>	<i>Color/Behavior</i>	<i>Explanation</i>
Power	Green	OK
	Not lit	No power/Error
Network	Orange	OK - network connected
	Orange flashing	Activity on network
	Not lit	No physical connection to the network

Web Interface

<i>Symptoms</i>	<i>Possible causes</i>	<i>Remedial actions</i>
The AXIS 5500/AXIS 5550 Web interface cannot be accessed from a Web browser.	The AXIS 5500/AXIS 5550 is not connected properly.	<ol style="list-style-type: none"> 1. Check Power and Network indicator. 2. Check that assignment of IP addresses for the AXIS 5500/AXIS 5550 is correct. 3. To further check the IP addresses, run the Ping command from another computer as described in "IP address check" at the end of this chapter. Follow the appropriate recommendations.
	Problem with your proxy server.	Verify the proxy server settings in your Web browser.
	Other networking problems.	<ol style="list-style-type: none"> 1. Verify that your network is accessible through your network socket. 2. Verify that your network cable is functional.

IP Address Check with Ping By sending a data packet to a specific IP address and waiting for a reply, Ping can determine whether that IP address is accessible. Ping can also help you to determine IP address conflicts with your AXIS 5500/AXIS 5550 and troubleshoot TCP/IP problems on the network. Follow the instructions below to diagnose your problem.

Windows: Open a Command Prompt and enter the following commands:

<i>Syntax</i>	<i>Example</i>
ping <IP address>	ping 192.168.3.191

The host will return reply from 192.168.3.191, or a similar message. This indicates that the address has been set and that communication is established

UNIX/Linux and Mac OS X Open a Terminal and enter the following commands:

<i>Syntax</i>	<i>Example</i>
ping <IP address>	ping 192.168.3.191

The host will return psname is alive, or a similar message. This indicates that the address has been set and that communication is established.

Replies: Subsequent replies will provide an explanation of the cause of the problem. Replies from DOS can be interpreted as defined in the table below (for UNIX/Linux replies please refer to the UNIX/Linux chapter of this manual):

<i>Ping Reply</i>	<i>Interpretation and recommendation</i>	
	<i>Axis Network Print Server connected</i>	<i>Axis Network Print Server disconnected</i>
bytes = 32 time = 2 ms..... - or something similar	The AXIS 5500/AXIS 5550 is responding correctly. There are probably no conflicts with the IP address – disconnect the AXIS 5500/AXIS 5550 and ping again to verify.	The IP address is already in use and cannot be used again. You must obtain a new IP address for your AXIS 5500/AXIS 5550.
destination host unreachable	The AXIS 5500/AXIS 5550 is not accessible. Check your network settings.	–
request timed out	The IP address is not in use. You are either pinging the wrong IP address or your AXIS 5500/AXIS 5550 does not have the correct IP address.	This IP address is not used by anyone and is available for use for your AXIS 5500/AXIS 5550. Set the IP address again, power on the AXIS 5500/AXIS 5550 and then try accessing the unit.
no response from ping command	The AXIS 5500/AXIS 5550 is not accessible. Check your network settings.	–

SNMP Device Index If you are using the TCP/IP protocol, check that the SNMP Device Index is correct. See “*SNMP Device Index*” on page 158.

Axis Support
Server Report

In order to obtain optimal support from Axis support technicians, please follow these instructions when submitting a Support question.

1. Go to the print server's Web pages by typing the print server's IP address in the **Address/Location** field of your Web browser.
2. Go to **Admin | Support**. Click the **Server Report** link. A new window will open.
3. Save the **Server report** as an HTML file (with an .html file extension) and go to www.axis.com
4. Choose **Support** and report your case, attaching the Server Report.

Please visit the Axis Web site for more support and additional help through the FAQ database.

Section 15 Technical Specification

Supported Printers	Low- and Full-Speed USB 1.1 and 2.0 printers. AXIS 5550 also supports all parallel printers except host-based printers and copiers, e.g. CAPT, GDI, PPA
Supported Systems	
Microsoft Windows	95, 98, Me, NT, 2000, XP and 2003
Novell NetWare	3.X, 4.X, 5.X, 6.X. Supports bindery and NDS mode. Supports user messages and printer status. NDPS supported over IP and IPX. Support for iPrint using both LPR and IPP protocols. PSERVER (IP/IPX), RPRINTER/NPRINTER supported
Apple	Mac OS 7, 8, 9, Mac OS X version 10.X
Unix/Linux	All Unix systems supporting TCP/IP (Linux, BSD, System V, Solaris, HP-UX, IBM AIX, Silicon Graphics IRIX, etc.)
Additional Systems	Other systems supporting TCP/IP: IBM (MVS, VM, VSE, OS/400), DEC, VMS Microsoft LAN Manager IBM LAN Server LANtastic
Supported Web browsers	Any standard Web browser (Netscape 6.x and higher and MS Internet Explorer 5.x and higher)
Supported Protocols	NetBIOS/NetBEUI
TCP/IP	ARP, DHCP, BOOTP, RARP, DNS, DDNS, Telnet, TFTP, FTP, LPR, Reverse Telnet, PROS, IPP, IP, TCP, UDP, HTTP, HTTPS, SSL/TLS, SNMP, SNMPv2c, v3, SLP v1/v2, ICMP, IGMP, Bonjour
NetWare	IPX, SPX, SAP, NCP (extended with NDS), NDPS, NLSP, LIP, RIP, RIP-II, OSPF
Apple EtherTalk	AAPR, ATP, DDP, NBP, PAP, RTMP, ZIP

Logical Printers	Logical printer ports can be programmed to perform auto ASCII to PostScript conversion, add string before and after job, string substitution, alternative output and character set conversion
Security	Password protected configuration SSL/TLS support for HTTPS security NetWare: Encrypted passwords, NetWare Packet Signature Level 1, 2, 3 Option to disable protocols
Print Server Management	AXIS ThinWizard for installation, configuration, monitoring and firmware upgrading of multiple units Bonjour support for quick and easy installation in Mac OS X environments AXIS AddPrinter for easy and automated installation in Windows environments Internal Web pages or FTP for installation, configuration, monitoring and firmware upgrading SNMP-MIB II compliant (RFC 1213), Axis private enterprise MIB included Netware: Full PCONSOLE, NWAdmin, ConsoleOne and iPrint-iManager support
Supported Languages	English, French, German, Italian, Japanese and Spanish
Firmware Upgrade	Firmware upgrade using AXIS ThinWizard, the print server's Web pages or FTP
Network Connection	All standard Ethernet and Fast Ethernet networks: RJ-45 connector (Category 5 or 6, shielded twisted pair cable) for 10baseT or 100baseTX Ethernet with full duplex Supports: IEEE802.2, IEEE802.3, SNAP and Ethernet II frame types simultaneously NWay for autodetection of network speed
Printer Connection	
AXIS 5500	One Low- and Full-Speed USB 1.1 port, which also works with USB 2.0 (Low-Speed and Full-Speed) printers. Note: The USB cable shipped with the product supports Low-Speed and Full-Speed. IMPORTANT! Hi-Speed is not supported

AXIS 5550 One Low- and Full-Speed USB 1.1 port, which also works with USB 2.0 (Low-Speed and Full-Speed) printers. Note: The USB cable shipped with the product supports Low-Speed and Full-Speed. **IMPORTANT!** Hi-Speed is not supported

One 36-pin Centronics connector parallel port, high-speed IEEE 1284 compliant

Hardware

Processor AXIS Etrax 100LX 32-bit 100 MHz RISC

Memory 2 MB Flash, 8 MB RAM

Front Panel 2 LED indicators: Power and Network
 Test button for information printouts

Power Consumption Power provided by external supply. Maximum 5.6W (Type PS-H, 5.1 VDC 2000mA)

Dimensions

AXIS 5500 Height: 2.9 cm/1.1 in
 Width: 6.2 cm/2.4 in
 Depth: 13.0 cm/5.1 in
 Weight: 0.077 kg/0.17 lb

AXIS 5550 Height: 2.9 cm/1.1 in
 Width: 6.2 cm/2.4 in
 Depth: 11.7 cm/4.6 in
 Weight: 0.081 kg/0.18 lb

Environmental Temperature: 40-105 °F (5-40 °C)
 Humidity: 10-90% non-condensing

Approvals

EMC -EN 55022/1998
 -EN 55024: 1998
 -EN 61000-3-2
 -EN 61000-3-3
 -VCCI Class B
 -C-TICK AS/NZS 3548
 -Compliance to FCC part 15 Subpart B, Class B

Safety EN 60950

Included Accessories AXIS Network Product CD with software for installation, management and printing, including AXIS ThinWizard (the recommended Axis management software for large enterprise networks) and AXIS AddPrinter (for easy and quick installation)

User documentation

Quick Installation Guide

Power adapter

Wall mounting clip

USB cable

All specifications are subject to change without prior notice.

Section 16 The Parameter List

This section provides an overview of the AXIS 5500 and AXIS 5550 print server parameters. See the Axis Web site for latest technical information.

The *config* File

See *Using FTP for Print Server Management*, on page 94 for information on how to fetch the print server's *config* file. The *config* file is built up like this:

```

--- General Menu
NODE_ADDR.      : 00 40 8C 18 1C F0
NETWORK_SPEED. : AUTO_SENSE (AUTO_SENSE, 10_HALF_DX,
10_FULL_DX, 100_HALF_DX, 100_FULL_DX)
PS_NAME.        : AXIS181CF0
USERS.          :
BASE_URL.       : www.axis.com
CHARSET.        : ISO-8859-1 (ISO-8859-1, UTF-8)
LANG.           : English (English, French, German, Spanish,
Italian, Japanese)
AXIS_PRINT_SYSTEM. : YES
RCONFIG_ENB.   : YES
DEF_OUT.        : PR1 (PR1, PR2, PR3, PR4, PR5, PR6, PR7, PR8,
LPT1, USB1)
SYS_LOC.        :
SYS_CONT.       :

```

To the left of the colon character (“:”), you will find each parameter. To the right of the colon you see the present value or state of the parameter, followed by a list of possible values (within brackets).

Example: The language parameter `LANG.` presently is set to `English`.

Parameters, Default Values, Possible Values and Comments

After a change, most parameters take effect for the next print job. For the others to take effect, you must restart the print server before the new setting for that parameter takes effect.

Four parameters (`ROOT_PWD.`, `USERS.`, `PROS_PWD.` and `WRT_COM.`) only appear when you are logged in to the print server as *root*. They will not be printed when you are printing the parameter list using the test button.

AXIS 5500 (AXIS 5500 Network Print Server V7.00 Oct 01 2004. S/N:
00408C611683)

Parameter settings:

--- General Menu

NODE_ADDR. : 00 40 8C 61 16 83

NETWORK_SPEED. : AUTO_SENSE (AUTO_SENSE, 10_HALF_DX,
10_FULL_DX, 100_HALF_DX, 100_FULL_DX)

PS_NAME. : AXIS611683

ROOT_PWD. : pass

USERS. :

BASE_URL. : www.axis.com

CHARSET. : ISO-8859-1 (SHIFT_JIS, ISO-8859-1, UTF-8)

LANG. : English (English, French, German, Spanish, Italian,
Japanese)

AXIS_PRINT_SYSTEM. : YES

RCONFIG_ENB. : YES

DEF_OUT. : PR1 (PR1, PR2, PR3, PR4, PR5, PR6, PR7, PR8, USB1)

SYS_LOC. :

SYS_CONT. :

--- LLC Menu

LLC_RESPONSE. : 1300

LLC_REC_ACK. : 20

LLC_INACTIVITY. : 15

--- TCP/IP Network Menu

INT_ADDR. : 10 91 2 40

DEF_ROUT. : 10 91 0 1

NET_MASK. : 255 255 0 0

HTTPS_ENB. : NO

DHCP_ENB. : YES

AUTOIP_ENB. : YES

BOOTP_ENB. : YES

RARP_ENB. : YES
WINS_ENB. : YES
WINS_ADDR1. : 10 0 5 50
WINS_ADDR2. : 0 0 0 0
NBT_SCOPE_ID. :
DNS_ENB. : YES
DNS_ADDR1. : 193 13 178 7
DNS_ADDR2. : 193 13 178 2
DOMAIN_NAME. : se.axis.com
SLP_ENB. : YES
SLP_SCOPE_LIST. : DEFAULT
RENDEZVOUS_ENB. : YES
RENDEZVOUS_SRVNAME_USB1. :
SMTP_SERVER. :
FTP_ENB. : YES
TELNET_ENB. : YES
DEF_IP_FRAME_TYPE. : EthernetII (EthernetII, SNAP)

--- TCP/IP Printing Menu

TCP_ENB. : YES
PAR_TCP_RESTRICT_LIST. :
PROS_PWD. : netprinter
PROS_PRT. : 35
LPD_BANN. : OFF (OFF, AUTO, LAST)
DEFAULT_RAW_TCP. : 9100 (9100, CLOSED)
RTN_OPT. : NO
RTEL_PR1. : 0
RTEL_PR2. : 0
RTEL_PR3. : 0
RTEL_PR4. : 0
RTEL_PR5. : 0
RTEL_PR6. : 0
RTEL_PR7. : 0
RTEL_PR8. : 0

--- SNMP Menu

SNMP_V1_ENB. : YES
SNMP_V2_ENB. : YES
READ_COM. : public
WRT_COM. : pass
TRAPADDR. : 0 0 0 0
TRAP_COM. : public
SYS_NAME. :
SNMP_AUT. : DISABLE (DISABLE, ENABLE)
TRAP_PRT. : DISABLE (DISABLE, ENABLE)

--- SNMPv3 Menu

SNMP_V3_ENB. : NO

--- NetWare Menu

NETW_ENB. : YES
NETW_TRANSPORT_PROTOCOL. : DUAL_STACK (IPX_ONLY, IP_ONLY,
DUAL_STACK)
NDPS. : TCP_AND_SPX (TCP_AND_SPX, TCP_ONLY, SPX_ONLY,
DISABLED)
JOB_CHECK_DELAY. : 5
CONF_CHECK_DELAY. : 300
FR_802_3. : YES
FR_ETH_2. : YES
FR_802_2. : YES
FR_SNAP. : YES
NCP_BURST_MODE. : YES
PSERVER_NDS_TREE. :
PSERVER_NDS_FILESERVER. :
PSERVER_NDS_DISTINGUISHED_NAME. :
PSERVER_BINDERY1. :
PSERVER_BINDERY2. :
PSERVER_BINDERY3. :

PSERVER_BINDERY4. :
PSERVER_BINDERY5. :
PSERVER_BINDERY6. :
PSERVER_BINDERY7. :
PSERVER_BINDERY8. :
PSERVER_BINDERY9. :
PSERVER_BINDERY10. :
PSERVER_BINDERY11. :
PSERVER_BINDERY12. :
PSERVER_BINDERY13. :
PSERVER_BINDERY14. :
PSERVER_BINDERY15. :
PSERVER_BINDERY16. :
NPRINTER1. :
NPRINTER2. :
NPRINTER3. :
NPRINTER4. :
NPRINTER5. :
NPRINTER6. :
NPRINTER7. :
NPRINTER8. :

--- NetBIOS/NetBEUI Menu
LSLM_ENB. : YES
NB_FR_TYPE. : FR_802_2 (FR_AUTO, FR_802_2, FR_DIX)
LPRINT_1. : AX611683.US1
LLOGIC_1. : PR1 (PR1, PR2, PR3, PR4, PR5, PR6, PR7, PR8, USB1)
LPRINT_2. :
LLOGIC_2. : PR2 (PR1, PR2, PR3, PR4, PR5, PR6, PR7, PR8, USB1)
LPRINT_3. :
LLOGIC_3. : PR3 (PR1, PR2, PR3, PR4, PR5, PR6, PR7, PR8, USB1)
LPRINT_4. :
LLOGIC_4. : PR4 (PR1, PR2, PR3, PR4, PR5, PR6, PR7, PR8, USB1)
LPRINT_5. :

LLOGIC_5. : PR5 (PR1, PR2, PR3, PR4, PR5, PR6, PR7, PR8, USB1)
LPRINT_6. :
LLOGIC_6. : PR6 (PR1, PR2, PR3, PR4, PR5, PR6, PR7, PR8, USB1)
LPRINT_7. :
LLOGIC_7. : PR7 (PR1, PR2, PR3, PR4, PR5, PR6, PR7, PR8, USB1)
LPRINT_8. :
LLOGIC_8. : PR8 (PR1, PR2, PR3, PR4, PR5, PR6, PR7, PR8, USB1)

--- AppleTalk Menu

ATLK_ENB. : YES
ATK_ZONE. :
ZONER_EN. : YES
ATK_FONT. : DEFAULT (DEFAULT, 35N, ALL)
AUTO_DT_PRIN1. : YES
APRINT_1. : AXIS611683_USB1
ATYPE_1. : LaserWriter
ALOGIC_1. : PR1 (PR1, PR2, PR3, PR4, PR5, PR6, PR7, PR8, USB1)
BINARY_TYPE_1. : TBCP (TBCP, BCP, NONE)
APRINT_2. : AXIS611683_2
ATYPE_2. :
ALOGIC_2. : PR2 (PR1, PR2, PR3, PR4, PR5, PR6, PR7, PR8, USB1)
BINARY_TYPE_2. : TBCP (TBCP, BCP, NONE)

--- Printer1 Menu

PR1_NAME. :
PR1_IN. : AUTO (AUTO, NONE)
PR1_BEF. :
PR1_STR. :
PR1_CSET. : NONE (NONE, ISO>IBM, 7UK>IBM, 7SW>IBM, 7GE>IBM,
7FR>IBM, 7ND>IBM, DEC>IBM)
PR1_FILT. : NONE (NONE, POSTSCR, AUTO_PS)
PR1_AFT. :
PR1_DUMP. : NO
PR1_SIZE. : A4 (A4, LETTER, LEGAL, EXECUT)

PR1_ORNT. : PORTR (PORTR, LANDS, R_PORTR, R_LANDS)

PR1_FORM. : 66 0 100 60 30 50

PR1_FONT. :

--- Printer2 Menu

PR2_NAME. :

PR2_IN. : AUTO (AUTO, NONE)

PR2_BEF. :

PR2_STR. :

PR2_CSET. : NONE (NONE, ISO>IBM, 7UK>IBM, 7SW>IBM, 7GE>IBM,
7FR>IBM, 7ND>IBM, DEC>IBM)

PR2_FILT. : NONE (NONE, POSTSCR, AUTO_PS)

PR2_AFT. :

PR2_DUMP. : NO

PR2_SIZE. : A4 (A4, LETTER, LEGAL, EXECUT)

PR2_ORNT. : PORTR (PORTR, LANDS, R_PORTR, R_LANDS)

PR2_FORM. : 66 0 100 60 30 50

PR2_FONT. :

--- Printer3 Menu

PR3_NAME. :

PR3_IN. : AUTO (AUTO, NONE)

PR3_BEF. :

PR3_STR. :

PR3_CSET. : NONE (NONE, ISO>IBM, 7UK>IBM, 7SW>IBM, 7GE>IBM,
7FR>IBM, 7ND>IBM, DEC>IBM)

PR3_FILT. : NONE (NONE, POSTSCR, AUTO_PS)

PR3_AFT. :

PR3_DUMP. : NO

PR3_SIZE. : A4 (A4, LETTER, LEGAL, EXECUT)

PR3_ORNT. : PORTR (PORTR, LANDS, R_PORTR, R_LANDS)

PR3_FORM. : 66 0 100 60 30 50

PR3_FONT. :

--- Printer4 Menu

PR4_NAME. :
PR4_IN. : AUTO (AUTO, NONE)
PR4_BEF. :
PR4_STR. :
PR4_CSET. : NONE (NONE, ISO>IBM, 7UK>IBM, 7SW>IBM, 7GE>IBM,
7FR>IBM, 7ND>IBM, DEC>IBM)
PR4_FILT. : NONE (NONE, POSTSCR, AUTO_PS)
PR4_AFT. :
PR4_DUMP. : NO
PR4_SIZE. : A4 (A4, LETTER, LEGAL, EXECUT)
PR4_ORNT. : PORTR (PORTR, LANDS, R_PORTR, R_LANDS)
PR4_FORM. : 66 0 100 60 30 50
PR4_FONT. :

--- Printer5 Menu

PR5_NAME. :
PR5_IN. : AUTO (AUTO, NONE)
PR5_BEF. :
PR5_STR. : 01 0A 02 0D 0A
PR5_CSET. : NONE (NONE, ISO>IBM, 7UK>IBM, 7SW>IBM, 7GE>IBM,
7FR>IBM, 7ND>IBM, DEC>IBM)
PR5_FILT. : NONE (NONE, POSTSCR, AUTO_PS)
PR5_AFT. :
PR5_DUMP. : NO
PR5_SIZE. : A4 (A4, LETTER, LEGAL, EXECUT)
PR5_ORNT. : PORTR (PORTR, LANDS, R_PORTR, R_LANDS)
PR5_FORM. : 66 0 100 60 30 50
PR5_FONT. :

--- Printer6 Menu

PR6_NAME. :
PR6_IN. : AUTO (AUTO, NONE)
PR6_BEF. :

PR6_STR. : 01 0A 02 0D 0A
PR6_CSET. : NONE (NONE, ISO>IBM, 7UK>IBM, 7SW>IBM, 7GE>IBM,
7FR>IBM, 7ND>IBM, DEC>IBM)
PR6_FILT. : NONE (NONE, POSTSCR, AUTO_PS)
PR6_AFT. :
PR6_DUMP. : NO
PR6_SIZE. : A4 (A4, LETTER, LEGAL, EXECUT)
PR6_ORNT. : PORTR (PORTR, LANDS, R_PORTR, R_LANDS)
PR6_FORM. : 66 0 100 60 30 50
PR6_FONT. :

--- Printer7 Menu

PR7_NAME. :
PR7_IN. : AUTO (AUTO, NONE)
PR7_BEF. :
PR7_STR. : 01 0A 02 0D 0A
PR7_CSET. : NONE (NONE, ISO>IBM, 7UK>IBM, 7SW>IBM, 7GE>IBM,
7FR>IBM, 7ND>IBM, DEC>IBM)
PR7_FILT. : NONE (NONE, POSTSCR, AUTO_PS)
PR7_AFT. :
PR7_DUMP. : NO
PR7_SIZE. : A4 (A4, LETTER, LEGAL, EXECUT)
PR7_ORNT. : PORTR (PORTR, LANDS, R_PORTR, R_LANDS)
PR7_FORM. : 66 0 100 60 30 50
PR7_FONT. :

--- Printer8 Menu

PR8_NAME. :
PR8_IN. : AUTO (AUTO, NONE)
PR8_BEF. :
PR8_STR. : 01 0A 02 0D 0A
PR8_CSET. : NONE (NONE, ISO>IBM, 7UK>IBM, 7SW>IBM, 7GE>IBM,
7FR>IBM, 7ND>IBM, DEC>IBM)
PR8_FILT. : NONE (NONE, POSTSCR, AUTO_PS)
PR8_AFT. :

PR8_DUMP. : NO
PR8_SIZE. : A4 (A4, LETTER, LEGAL, EXECUT)
PR8_ORNT. : PORTR (PORTR, LANDS, R_PORTR, R_LANDS)
PR8_FORM. : 66 0 100 60 30 50
PR8_FONT. :

--- USB1 Menu

U1_MGM_INFO. : AUTO (DISABLE, AUTO)
U1_COMMENT. :
U1_BIDIR. : AUTO (DISABLE, AUTO)
U1_READT. : 3
U1_BUFFER_SIZE. : 0
U1_PORT_STATUS_OVERRIDE. : NO

--- Email Menu

EMAIL_NOTIFICATION. : NO
REPLY_ADDRESS. :
PAPER_JAM_ADDRESS. :
OUT_OF_PAPER_ADDRESS. :
TONER_LOW_ADDRESS. :
NO_TONER_ADDRESS. :
PRINTER_OFFLINE_ADDRESS. :

AXIS 5550 (AXIS 5550 Network Print Server V7.00 Sep 21 2004. S/N:
00408C61025B)

Parameter settings:

--- General Menu

NODE_ADDR. : 00 40 8C 61 02 5B

NETWORK_SPEED. : AUTO_SENSE (AUTO_SENSE, 10_HALF_DX,
10_FULL_DX, 100_HALF_DX, 100_FULL_DX)

PS_NAME. : AXIS61025B

ROOT_PWD. : pass

USERS. :

BASE_URL. : www.axis.com

CHARSET. : ISO-8859-1 (SHIFT_JIS, ISO-8859-1, UTF-8)

LANG. : English (English, French, German, Spanish, Italian,
Japanese)

AXIS_PRINT_SYSTEM. : YES

RCONFIG_ENB. : YES

DEF_OUT. : PR1 (PR1, PR2, PR3, PR4, PR5, PR6, PR7, PR8, LPT1,
USB1)

SYS_LOC. :

SYS_CONT. :

--- LLC Menu

LLC_RESPONSE. : 1300

LLC_REC_ACK. : 20

LLC_INACTIVITY. : 15

--- TCP/IP Network Menu

INT_ADDR. : 10 91 2 40

DEF_ROUT. : 10 91 0 1

NET_MASK. : 255 255 0 0

HTTPS_ENB. : NO

DHCP_ENB. : YES

AUTOIP_ENB. : YES

BOOTP_ENB. : YES
RARP_ENB. : YES
WINS_ENB. : YES
WINS_ADDR1. : 10 0 5 50
WINS_ADDR2. : 0 0 0 0
NBT_SCOPE_ID. :
DNS_ENB. : YES
DNS_ADDR1. : 193 13 178 7
DNS_ADDR2. : 193 13 178 2
DOMAIN_NAME. : se.axis.com
SLP_ENB. : YES
SLP_SCOPE_LIST. : DEFAULT
RENDEZVOUS_ENB. : YES
RENDEZVOUS_SRVNAME_LPT1. :
RENDEZVOUS_SRVNAME_USB1. :
SMTP_SERVER. :
FTP_ENB. : YES
TELNET_ENB. : YES
DEF_IP_FRAME_TYPE. : EthernetII (EthernetII, SNAP)

--- TCP/IP Printing Menu

TCP_ENB. : YES
PAR_TCP_RESTRICT_LIST. :
PROS_PWD. : netprinter
PROS_PRT. : 35
LPD_BANN. : OFF (OFF, AUTO, LAST)
DEFAULT_RAW_TCP. : 9100-9101 (9100-9101, CLOSED)
RTN_OPT. : NO
RTEL_PR1. : 0
RTEL_PR2. : 0
RTEL_PR3. : 0
RTEL_PR4. : 0
RTEL_PR5. : 0
RTEL_PR6. : 0

RTEL_PR7. : 0

RTEL_PR8. : 0

--- SNMP Menu

SNMP_V1_ENB. : YES

SNMP_V2_ENB. : YES

READ_COM. : public

WRT_COM. : pass

TRAPADDR. : 0 0 0 0

TRAP_COM. : public

SYS_NAME. :

SNMP_AUT. : DISABLE (DISABLE, ENABLE)

TRAP_PRT. : DISABLE (DISABLE, ENABLE)

--- SNMPv3 Menu

SNMP_V3_ENB. : NO

--- NetWare Menu

NETW_ENB. : YES

NETW_TRANSPORT_PROTOCOL. : DUAL_STACK (IPX_ONLY, IP_ONLY, DUAL_STACK)

NDPS. : TCP_AND_SPX (TCP_AND_SPX, TCP_ONLY, SPX_ONLY, DISABLED)

JOB_CHECK_DELAY. : 5

CONF_CHECK_DELAY. : 300

FR_802_3. : YES

FR_ETH_2. : YES

FR_802_2. : YES

FR_SNAP. : YES

NCP_BURST_MODE. : YES

PSERVER_NDS_TREE. :

PSERVER_NDS_FILESERVER. :

PSERVER_NDS_DISTINGUISHED_NAME. :

PSERVER_BINDERY1. :

PSERVER_BINDERY2. :
PSERVER_BINDERY3. :
PSERVER_BINDERY4. :
PSERVER_BINDERY5. :
PSERVER_BINDERY6. :
PSERVER_BINDERY7. :
PSERVER_BINDERY8. :
PSERVER_BINDERY9. :
PSERVER_BINDERY10. :
PSERVER_BINDERY11. :
PSERVER_BINDERY12. :
PSERVER_BINDERY13. :
PSERVER_BINDERY14. :
PSERVER_BINDERY15. :
PSERVER_BINDERY16. :

NPRINTER1. :
NPRINTER2. :
NPRINTER3. :
NPRINTER4. :
NPRINTER5. :
NPRINTER6. :
NPRINTER7. :
NPRINTER8. :

--- NetBIOS/NetBEUI Menu

LSLM_ENB. : YES
NB_FR_TYPE. : FR_802_2 (FR_AUTO, FR_802_2, FR_DIX)
LPRINT_1. : AX61025B.LP1
LLOGIC_1. : PR1 (PR1, PR2, PR3, PR4, PR5, PR6, PR7, PR8, LPT1,
USB1)
LPRINT_2. : AX61025B.US1
LLOGIC_2. : PR2 (PR1, PR2, PR3, PR4, PR5, PR6, PR7, PR8, LPT1,
USB1)
LPRINT_3. :

LLOGIC_3. : PR3 (PR1, PR2, PR3, PR4, PR5, PR6, PR7, PR8, LPT1, USB1)
LPRINT_4. :
LLOGIC_4. : PR4 (PR1, PR2, PR3, PR4, PR5, PR6, PR7, PR8, LPT1, USB1)
LPRINT_5. :
LLOGIC_5. : PR5 (PR1, PR2, PR3, PR4, PR5, PR6, PR7, PR8, LPT1, USB1)
LPRINT_6. :
LLOGIC_6. : PR6 (PR1, PR2, PR3, PR4, PR5, PR6, PR7, PR8, LPT1, USB1)
LPRINT_7. :
LLOGIC_7. : PR7 (PR1, PR2, PR3, PR4, PR5, PR6, PR7, PR8, LPT1, USB1)
LPRINT_8. :
LLOGIC_8. : PR8 (PR1, PR2, PR3, PR4, PR5, PR6, PR7, PR8, LPT1, USB1)

--- AppleTalk Menu

ATLK_ENB. : YES
ATK_ZONE. :
ZONER_EN. : YES
ATK_FONT. : DEFAULT (DEFAULT, 35N, ALL)
AUTO_DT_PRIN1. : YES
APRINT_1. : AXIS61025B_LPT1
ATYPE_1. : LaserWriter
ALOGIC_1. : PR1 (PR1, PR2, PR3, PR4, PR5, PR6, PR7, PR8, LPT1, USB1)
BINARY_TYPE_1. : TBCP (TBCP, BCP, NONE)
AUTO_DT_PRIN2. : YES
APRINT_2. : AXIS61025B_USB1
ATYPE_2. : LaserWriter
ALOGIC_2. : PR2 (PR1, PR2, PR3, PR4, PR5, PR6, PR7, PR8, LPT1, USB1)
BINARY_TYPE_2. : TBCP (TBCP, BCP, NONE)

--- Printer1 Menu

PR1_OUT. : LPT1 (NONE, LPT1, USB1)
PR1_NAME. :
PR1_SCND. : PR1 (PR1, PR2, PR3, PR4, PR5, PR6, PR7, PR8)
PR1_WAIT. : YES
PR1_IN. : AUTO (AUTO, NONE)
PR1_BEF. :
PR1_STR. :
PR1_CSET. : NONE (NONE, ISO>IBM, 7UK>IBM, 7SW>IBM, 7GE>IBM,
7FR>IBM, 7ND>IBM, DEC>IBM)
PR1_FILT. : NONE (NONE, POSTSCR, AUTO_PS)
PR1_AFT. :
PR1_DUMP. : NO
PR1_SIZE. : A4 (A4, LETTER, LEGAL, EXECUT)
PR1_ORNT. : PORTR (PORTR, LANDS, R_PORTR, R_LANDS)
PR1_FORM. : 66 0 100 60 30 50
PR1_FONT. :

--- Printer2 Menu

PR2_OUT. : USB1 (NONE, LPT1, USB1)
PR2_NAME. :
PR2_SCND. : PR2 (PR1, PR2, PR3, PR4, PR5, PR6, PR7, PR8)
PR2_WAIT. : YES
PR2_IN. : AUTO (AUTO, NONE)
PR2_BEF. :
PR2_STR. :
PR2_CSET. : NONE (NONE, ISO>IBM, 7UK>IBM, 7SW>IBM, 7GE>IBM,
7FR>IBM, 7ND>IBM, DEC>IBM)
PR2_FILT. : NONE (NONE, POSTSCR, AUTO_PS)
PR2_AFT. :
PR2_DUMP. : NO
PR2_SIZE. : A4 (A4, LETTER, LEGAL, EXECUT)
PR2_ORNT. : PORTR (PORTR, LANDS, R_PORTR, R_LANDS)
PR2_FORM. : 66 0 100 60 30 50

PR2_FONT. :

--- Printer3 Menu

PR3_OUT. : LPT1 (NONE, LPT1, USB1)

PR3_NAME. :

PR3_SCND. : PR3 (PR1, PR2, PR3, PR4, PR5, PR6, PR7, PR8)

PR3_WAIT. : YES

PR3_IN. : AUTO (AUTO, NONE)

PR3_BEF. :

PR3_STR. :

PR3_CSET. : NONE (NONE, ISO>IBM, 7UK>IBM, 7SW>IBM, 7GE>IBM, 7FR>IBM, 7ND>IBM, DEC>IBM)

PR3_FILT. : NONE (NONE, POSTSCR, AUTO_PS)

PR3_AFT. :

PR3_DUMP. : NO

PR3_SIZE. : A4 (A4, LETTER, LEGAL, EXECUT)

PR3_ORNT. : PORTR (PORTR, LANDS, R_PORTR, R_LANDS)

PR3_FORM. : 66 0 100 60 30 50

PR3_FONT. :

--- Printer4 Menu

PR4_OUT. : USB1 (NONE, LPT1, USB1)

PR4_NAME. :

PR4_SCND. : PR4 (PR1, PR2, PR3, PR4, PR5, PR6, PR7, PR8)

PR4_WAIT. : YES

PR4_IN. : AUTO (AUTO, NONE)

PR4_BEF. :

PR4_STR. :

PR4_CSET. : NONE (NONE, ISO>IBM, 7UK>IBM, 7SW>IBM, 7GE>IBM, 7FR>IBM, 7ND>IBM, DEC>IBM)

PR4_FILT. : NONE (NONE, POSTSCR, AUTO_PS)

PR4_AFT. :

PR4_DUMP. : NO

PR4_SIZE. : A4 (A4, LETTER, LEGAL, EXECUT)

PR4_ORNT. : PORTR (PORTR, LANDS, R_PORTR, R_LANDS)
PR4_FORM. : 66 0 100 60 30 50
PR4_FONT. :

--- Printer5 Menu

PR5_OUT. : LPT1 (NONE, LPT1, USB1)
PR5_NAME. :
PR5_SCND. : PR5 (PR1, PR2, PR3, PR4, PR5, PR6, PR7, PR8)
PR5_WAIT. : YES
PR5_IN. : AUTO (AUTO, NONE)
PR5_BEF. :
PR5_STR. : 01 0A 02 0D 0A
PR5_CSET. : NONE (NONE, ISO>IBM, 7UK>IBM, 7SW>IBM, 7GE>IBM,
7FR>IBM, 7ND>IBM, DEC>IBM)
PR5_FILT. : NONE (NONE, POSTSCR, AUTO_PS)
PR5_AFT. :
PR5_DUMP. : NO
PR5_SIZE. : A4 (A4, LETTER, LEGAL, EXECUT)
PR5_ORNT. : PORTR (PORTR, LANDS, R_PORTR, R_LANDS)
PR5_FORM. : 66 0 100 60 30 50
PR5_FONT. :

--- Printer6 Menu

PR6_OUT. : USB1 (NONE, LPT1, USB1)
PR6_NAME. :
PR6_SCND. : PR6 (PR1, PR2, PR3, PR4, PR5, PR6, PR7, PR8)
PR6_WAIT. : YES
PR6_IN. : AUTO (AUTO, NONE)
PR6_BEF. :
PR6_STR. : 01 0A 02 0D 0A
PR6_CSET. : NONE (NONE, ISO>IBM, 7UK>IBM, 7SW>IBM, 7GE>IBM,
7FR>IBM, 7ND>IBM, DEC>IBM)
PR6_FILT. : NONE (NONE, POSTSCR, AUTO_PS)
PR6_AFT. :

PR6_DUMP. : NO
PR6_SIZE. : A4 (A4, LETTER, LEGAL, EXECUT)
PR6_ORNT. : PORTR (PORTR, LANDS, R_PORTR, R_LANDS)
PR6_FORM. : 66 0 100 60 30 50
PR6_FONT. :

--- Printer7 Menu

PR7_OUT. : LPT1 (NONE, LPT1, USB1)
PR7_NAME. :
PR7_SCND. : PR7 (PR1, PR2, PR3, PR4, PR5, PR6, PR7, PR8)
PR7_WAIT. : YES
PR7_IN. : AUTO (AUTO, NONE)
PR7_BEF. :
PR7_STR. : 01 0A 02 0D 0A
PR7_CSET. : NONE (NONE, ISO>IBM, 7UK>IBM, 7SW>IBM, 7GE>IBM,
7FR>IBM, 7ND>IBM, DEC>IBM)
PR7_FILT. : NONE (NONE, POSTSCR, AUTO_PS)
PR7_AFT. :
PR7_DUMP. : NO
PR7_SIZE. : A4 (A4, LETTER, LEGAL, EXECUT)
PR7_ORNT. : PORTR (PORTR, LANDS, R_PORTR, R_LANDS)
PR7_FORM. : 66 0 100 60 30 50
PR7_FONT. :

--- Printer8 Menu

PR8_OUT. : USB1 (NONE, LPT1, USB1)
PR8_NAME. :
PR8_SCND. : PR8 (PR1, PR2, PR3, PR4, PR5, PR6, PR7, PR8)
PR8_WAIT. : YES
PR8_IN. : AUTO (AUTO, NONE)
PR8_BEF. :
PR8_STR. : 01 0A 02 0D 0A
PR8_CSET. : NONE (NONE, ISO>IBM, 7UK>IBM, 7SW>IBM, 7GE>IBM,
7FR>IBM, 7ND>IBM, DEC>IBM)

PR8_FILT. : NONE (NONE, POSTSCR, AUTO_PS)
PR8_AFT. :
PR8_DUMP. : NO
PR8_SIZE. : A4 (A4, LETTER, LEGAL, EXECUT)
PR8_ORNT. : PORTR (PORTR, LANDS, R_PORTR, R_LANDS)
PR8_FORM. : 66 0 100 60 30 50
PR8_FONT. :

--- LPT1 Menu

L1_CENTR. : HISPEED (IBM_PC, STNDRD, FAST, HISPEED, HINOACK)
L1_BSYTM. : 60
L1_MGM_INFO. : AUTO (DISABLE, AUTO)
L1_COMMENT. :
L1_BIDIR. : AUTO (DISABLE, AUTO)
L1_READT. : 3

--- USB1 Menu

U1_MGM_INFO. : AUTO (DISABLE, AUTO)
U1_COMMENT. :
U1_BIDIR. : AUTO (DISABLE, AUTO)
U1_READT. : 3
U1_BUFFER_SIZE. : 0
U1_PORT_STATUS_OVERRIDE. : NO

--- Email Menu

EMAIL_NOTIFICATION. : NO
REPLY_ADDRESS. :
PAPER_JAM_ADDRESS. :
OUT_OF_PAPER_ADDRESS. :
TONER_LOW_ADDRESS. :
NO_TONER_ADDRESS. :
PRINTER_OFFLINE_ADDRESS. :

NetWare Parameter Combinations

When NetWare is enabled (i.e. when the NETW_ENB. parameter is set to “yes” in the NetWare Menu), the different settings of the NETW_TRANSPORT_PROTOCOL. and NDPS. parameters will result in these functionalities:

NETW_ENB	NETW_TRANSPORT_PROTOCOL	NDPS	Functionality
YES	DUAL_STACK	TCP_AND_SPX	1, 2, 3, 4, 5, 6, 7
YES	DUAL_STACK	TCP_ONLY	1, 2, 3, 5, 6, 7
YES	DUAL_STACK	SPX_ONLY	2, 3, 4, 5, 6, 7
YES	DUAL_STACK	DISABLED	3, 5, 6, 7
YES	IP_ONLY	TCP_AND_SPX	1, 2, 5
YES	IP_ONLY	TCP_ONLY	1, 2, 5
YES	IP_ONLY	SPX_ONLY	2, 5
YES	IP_ONLY	DISABLED	5
YES	IPX_ONLY	TCP_AND_SPX	2, 3, 4, 6, 7
YES	IPX_ONLY	TCP_ONLY	2, 3, 6, 7
YES	IPX_ONLY	SPX_ONLY	2, 3, 4, 6, 7
YES	IPX_ONLY	DISABLED	3, 6, 7

- Functionality
1. Raw TCP ports 9100 = LPT1 and 9101 = USB1 are opened for NDPS printing. To create TCP NDPS printer objects, AXIS_PRINT_SYSTEM must be enabled (see Note a).
 2. The HP-MIB is enabled.
 3. Services are SAP'ed and enabled on SPX sockets 8060 and 4114 (see Notes b and c).
 4. Print services are SAP'ed and enabled on SPX sockets, 400C = LPT1 and 401C = USB1 (see Notes b and c).
 5. Pure IP queue mode printing is enabled.
 6. IPX queue mode printing is enabled (see Note c).
 7. Looking for SAP NetWare file servers on the net (see Note c).

- Notes:
- (a) TCP printing must be enabled (TCP_ENB. = YES).
 - (b) Some other SAP service must be present on the network.
 - (c) At least one frametype must be enabled for NetWare.

TCP Ports Opened for Raw Printing

AXIS 5500

Port Number	Port	Via Logical Printer	Condition
9100	USB1	–	DEFAULT_RAW_TCP. set to 9100
9902	USB1	–	AXIS_PRINT_SYSTEM. Enabled
9101	USB1	–	NDPS. Enabled

AXIS 5550

Port Number	Port	Via Logical Printer	Condition
9100	LPT1	–	DEFAULT_RAW_TCP. set to 9100
9101	USB1	–	
9900	LPT1	–	AXIS_PRINT_SYSTEM. Enabled
9902	USB1	–	
9100	LPT1	–	NDPS. Enabled
9101	USB1	–	

Note: The TCP port numbers entered in RTEL_PRx. will override the settings in the two tables above.

SNMP Device Index

When using the TCP/IP protocol (and if the printer driver permits), the print server can use **SNMP Status** to find out if the printer is ready to accept a new job.

By default, Windows uses the value “1” when addressing an SNMP device, which is correct for single port print servers. For a multiport print server, obtain the SNMP Device Index from the table below.

<i>Print Server</i>	<i>LPR Queue Name</i>	<i>Raw Port Number</i>	<i>SNMP Device Index</i>
Single Port: Parallel	LPT1	9100	1
Single Port: USB	USB1	9100	1
Dual Port: Parallel USB	LPT1 USB1	9100 9101	1 2
Dual Port: Parallel Parallel	LPT1 LPT2	9100 9101	1 2
Three Port: Parallel Parallel Serial	LPT1 LPT2 COM1	9100 9101 9102	1 3 2

Enable SNMP Status SNMP Status is enabled through Windows' printer port settings.

Example You have a three port print server and want to enable SNMP Status for LPT2. The table above tells you to set the SNMP Device Index to 3.

Using Windows XP as an example:

1. Go to **Start | Printers and Faxes**.
2. Select **Printer** and then **Properties**.
3. Select **Port** and mark the **Port** you would like to change.
4. Click **Configure Port...**

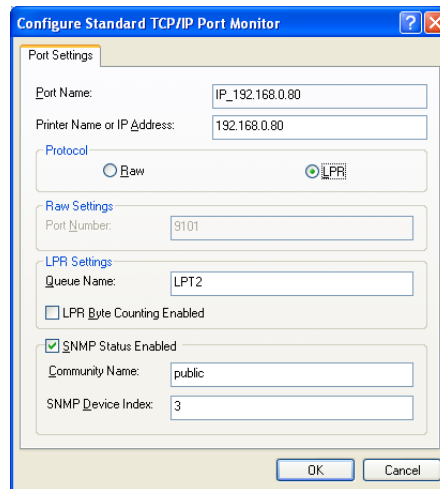

5. Ensure that **SNMP Status Enabled** is ticked and enter the correct index number in **SNMP Device Index**, taken from the table above (3 in this example).
6. Click **OK** and **Close**.

Section 17 Glossary

- AIX** Advanced Interactive eXecutive. A version of the UNIX operating system from IBM that runs on various IBM computers including Mainframe systems.
- AppleTalk** A local area network protocol for communication between Apple Computer products and other computers and peripherals.
- ARP** Address Resolution Protocol. A protocol within the TCP/IP suite of network protocols that allows a host to find the physical address of a node on the same network. ARP cannot be used across routers.
- Authentication** Verification of identity, for instance by use of digital signatures.
- Auto-IP** A method to automatically set an IP address in the absence of a DHCP server.
- Bonjour** Bonjour enables automatic discovery of computers, devices, and services on IP networks without the need to enter IP addresses or configure DNS servers.
- BOOTP** BOOT Protocol. A TCP/IP protocol, used for downloading start-up information such as the IP address to hosts on the network. BOOTP requires a BOOTP daemon on your system. A request made to an active BOOTP daemon initiates a search of the Boot Table for an entry matching the print server's Ethernet address. If a matching entry is found, the daemon downloads the IP address to the print server.
- BSD** Berkeley Software Distribution. The University of California, Berkeley additions to the UNIX operating system.
- Certificate Authority, CA** An organization or company that issues digital certificates.
- config* File** This is a file that resides in the print server's memory and contains all the parameters that determine the print server's functionality. By editing the *config* file (changing the parameter settings), you can configure the print server to meet the printing needs of your network.
- Client/server Printing** Means that print jobs are sent to a file server, with different clients attached to the print queue, rather than directly to the print server (Peer-to-Peer printing).

- DHCP** Dynamic Host Configuration Protocol. Enables e.g. a print server to automatically obtain an unused IP address from the DHCP server.
- To fully benefit from this method, the print server also supports DDNS, which is available in Windows 2000 networks.
- Digital Certificate** Used to create digital signatures and public/private key pairs for secure Web services.
- DNS** Domain Name System. Resolves host names into IP addresses.
- Dynamic DNS** Dynamic Domain Name System. Allows hosts to dynamically change the IP address in DNS, e.g. when the host is given a new IP address by DHCP.
- Firmware** Firmware is the print server's internal software.
- Flash Memory** The print server firmware is stored in Flash memory.
- FTP** File Transfer Protocol. A TCP/IP protocol used for logging in to network servers and for transferring files.
- HTML** Hypertext Markup Language. A standard hypertext language used for creating World Wide Web pages and other hypertext documents.
- HTTP** Hypertext Transfer Protocol. The TCP/IP protocol for Web based communication.
- HTTPS** HyperText Transmission Protocol, Secure, i.e. HTTP for secure transactions.
- IP** Internet Protocol. The TCP/IP network-layer protocol that regulates packet forwarding by tracking IP addresses, routing outgoing messages and recognizing incoming messages.
- IPP** Internet Printing Protocol. A developing industry standard that allows users to print to remote printers across the Internet. With IPP, a user with an Internet connection can send a document to any printer connected to the Internet. IPP is platform independent and can be used to print over any LAN or WAN that supports TCP/IP.
- IPX** Internetwork Packet Exchange, a networking protocol used by NetWare.
- LAN** Local Area Network.
- LED** Light Emitting Diode.

- Linux** An open source implementation of UNIX.
- LLC** Logical Link Control. An additional data link layer protocol which operates on top of the MAC protocol defined in the original Ethernet standard (the "Blue Book").
- LPD** The Line Printer Daemon is a protocol for transferring print jobs between hosts. This is the recommended method for UNIX/Linux systems, but some System V versions do not support LPD.
- Logical Printer** A logical printer acts as a filter between the network and the physical printer. It appears to the user as a normal printer with additional characteristics. For example a UNIX/Linux workstation may only send a line feed (LF) to a shared printer that needs carriage return (CR) and LF. The logical printer can solve this problem by adding a CR whenever a line feed is detected.
- NCP** NetWare Core Protocol. Network clients use the NCP to request services of servers, and servers use NCP to provide services, such as file and print services.
- NDPS** Novell's Distributed Printing Services.
- NDS** NetWare Directory Services. A hierarchical data base that manages NetWare network resources such as servers and volumes.
- NetBIOS/NetBEUI** Network Basic Input Output System, a network protocol with special functions for local area networks. NetBIOS Enhanced User Interface is an enhanced version of NetBIOS.
- NetWare** An operating system for local area networks.
- PCL** Printer Control Language – a set of command codes used when printing. A PCL driver is a small program that works between the operating system and the printer.
- Peer-to-Peer Printing** When selecting Peer-to-peer printing, all print jobs are sent directly to the print server, rather than through a file server (client/server).
- PEM** Privacy Enhanced Mail.
- RARP** Reverse Address Resolution Protocol. A TCP/IP protocol used for downloading IP addresses in UNIX/Linux networks. It requires a RARP daemon on your system, and only operates within a single network segment. A request made to an active RARP daemon initiates a search of

the Ethernet Address Table for an entry matching the print server's Ethernet address. If a matching entry is found, the daemon downloads the IP address to the print server.

- RISC** Reduced Instruction Set Computing. A processor designed to increase performance, using a limited set of assembly language instructions.
- SAP** Service Advertising Protocol. A NetWare network name advertising service that e.g. file servers can use for advertising their existence to network clients.
- SNMP** Simple Network Management Protocol. Standard management protocol for network attached devices.
- SSL** Secure Sockets Layer, a protocol designed to provide secure communications on the Internet.
- SPX** Sequenced Packet Exchange, a NetWare communications protocol used to transmit messages reliably over a network.
- TCP** Transmission Control Protocol. The connection-oriented, transport-level protocol used in the TCP/IP suite of protocols.
- Telnet** A terminal emulation program for networks, often used to remotely control Web servers.
- TFTP** Trivial File Transfer Protocol (TFTP) is an Internet software utility for transferring files that is simpler to use than the File Transfer Protocol (FTP) but less capable. It is used where user authentication and directory visibility are not required. TFTP uses the User Datagram Protocol (UDP) rather than the Transmission Control Protocol (TCP).
- TLS** Transport Layer Security, a protocol that guarantees privacy and data integrity between applications communicating over the Internet.
- UNIX** A 32-bit multi-tasking, multi-user operating system originally developed by AT&T.
- URL** Uniform Resource Locator. A way of specifying the location of information on the Internet.
- USB** Universal Serial Bus.
- WAN** Wide Area Network.

WINS Windows Internet Name Service. A NetBIOS Name Server that maps NetBIOS names to dynamically assigned IP addresses.

Wizard A special form of user assistance that automates a task through a dialog with the user. Wizards help the user to accomplish tasks that are complex and require experience, and even for the experienced user can help to speed up an operation.

Index

A	
Account file.....	96
Admin.....	89
AIX.....	160
AppleTalk.....	42, 160
ASCII to Postscript Conversion.....	115
Assistance.....	6
Authentication.....	160
Autodetect.....	42
Autodetect Printer Type.....	44, 101
Auto-IP.....	19, 101, 160
Auto-IP Addressing.....	127
AXIS AddPrinter Wizard.....	24
AXIS IPP Gateway Configuration.....	61
AXIS LPR Gateway Configuration.....	61
AXIS MIB.....	99
AXIS Print Monitor.....	33
AXIS Print Utility for OS/2.....	83
AXIS ThinWizard	
Installing.....	92
B	
Basic setup	
AXIS NetPilot.....	65
TCP/IP.....	15
BCP and TBCP.....	44
Bi-directional Printing.....	117
Binary Protocol for Printer.....	44
Bonjour.....	160
Change Service Name.....	40
Printing.....	39
BSD.....	160
C	
CA.....	160
Certificate Authority.....	160
Certificates.....	121
Delete.....	123
Import.....	122
View.....	123
Change Bonjour Service Name.....	40
Character Set Conversion.....	111
Checking SSL/TLS Status.....	123
Client/Server Printing.....	160
Config File.....	137, 160
config file.....	88

Configuration methods	
FTP	95
NetWare Administrator	71, 99
PCONSOLE	71, 99
SNMP	98
Telnet	96
Web browser	89
Conversions	111, 112, 115
Creating a Network Group	93
D	
DDNS	16, 127
DDNS Host Name Rules	127
Debugging	117
Hex Dump Mode	117
Print Problems	117
Default Gateway/Router	125
Default printer port	129
Default printer port - printing test page	129
Delete Certificate	123
Description	10
DHCP Addressing	126
Digital Certificate	161
Disabling Protocols	123
DNS	161
Dynamic DNS	161
E	
Enable SNMP Status	159
Enabling Protocols	123
Enabling SSL	121
Enabling the SNMPv3 Protocol	124
F	
Factory Default	92
Firmware	161
Upgrade	92
Flash Loading over the Web	85, 119
Flash Memory	161
FTP	94, 161
FTP Enabled	86, 94
Full-Speed	10
G	
Glossary	160
H	
Hex Dump Mode	117
Hi-Speed Compliance	10
Host Name	16, 127
HTML	161

HTTP	161
HTTPS	122, 161
I	
IEEE 1284 Parallel Port	135
IEEE 1284 parallel port	10
Importing a Certificate	122
Indicators	11, 130
Installing AXIS ThinWizard	92
Internet Address	65
IP	161
IP Address	125
Automatic Assignment Methods.....	15
Checking, using Ping.....	131
Manual Assignment Methods.....	16
Setting - Macintosh	44
Setting, using ARP	20
Setting, using Auto-IP	19
Setting, using BOOTP	19
Setting, using DHCP	17, 128
Setting, using RARP	17, 128
IP address - Subnet Mask - Default Gateway Example	126
IP Address and Subnet Mask	125
IP Address and Subnet Mask Structures	125
IPP.....	161
Client	103
Printing Requirements	103
iPrint.....	46, 99
IPX	161
L	
Label, backside	14
LAN.....	161
LED	130, 161
Linux.....	162
LLC	162
Local Printer	31
Logical Link Control.....	162
Logical Printers	111, 162
Low-Speed	10
LPD	80, 162
M	
Macintosh	
Choosing a Printer	42
Installing the Print Server.....	42
Mounting the AXIS 5500/AXIS 5550.....	11
N	
NCP.....	162
NDPS.....	46, 47, 162

NDS.....	67, 162
NetBIOS/NetBEUI	162
NetWare	162
Advanced installation.....	67
Basic installation	65
NDPS	47, 104
NetWare Packet Signature	118
NetWare Packet Signature Levels	118
NetWare Parameter Combinations	157
NetWare printing modes	
Print Server Mode.....	70
Remote Printer Mode	70
Network	
Connector.....	10
Indicator.....	11, 130
Printer	32
Speed	118
Structures.....	21
Network Group	
Create.....	93
O	
Obtaining an IP Address and Subnet Mask	126
OS/2	
AXIS Print Utility for OS/2	83
Installing the print server	83
Overriding Port Status.....	123
P	
Parameter Combinations.....	157
Parameter List.....	91, 129
PCL	162
Peer-to-Peer Printing	162
PEM	162
Port status	
Override	123
Ports.....	10
Opened for Raw Printing	158
Power	
Indicator.....	11, 130
Print Jobs	
Redirect	116
Print Problems	
Debugging	117
Printer	
Autodetect	42
Ports.....	10

Printing	
Bi-directional	117
Client/Server.....	160
Parameter List	129
Peer-to-Peer.....	162
Test Page	129
Protocols	
Disable	123
Enable	123
Pure IP	69
Q	
Queue-based printing	46
R	
Raw Printing	158
Redirecting Print Jobs.....	116
Restart	91
RISC	163
S	
SAP	163
Secure Web Services.....	121
Security Settings.....	91
Server Report	132
Setting up	
NetWare.....	46
OS/2	82
Snap-in for iPrint	61
SNMP	98, 163
SNMP Device Index.....	24, 99, 131, 158
SNMP Status.....	158
SNMPv3	124
SPX	163
SSL	121, 163
SSL/TLS	
Status.....	123
Starting AXIS ThinWizard	92
Static Addressing	126
Status file	96, 97
String Functions	112
String Substitutions	113
Subnet Mask	125
Substitutions.....	113
Support.....	6, 132
Supported Environments and Printers.....	7
T	
TCP	163
TCP Ports Opened for Raw Printing.....	158
TCP printing restriction list	120

TCP/IP Restrictions	120
Tcpmon.ini	29
Technical Assistance	6, 132
Telnet	163
Test Button	11, 129
Test Page	129
TFTP	19, 163
TLS	121, 163
Troubleshooting	130
U	
UNIX	163
UNIX/Linux Printing Methods	
FTP	80
LPD	80
PROS A	81
PROS B	81
Reverse Telnet	81
Update Initial User	124
Upgrading	85
URL	163
USB	163
1.1 compliance	10, 134, 135
2.0 compliance	134, 135
Cable Compliance	10, 134, 135
Full-Speed	10, 134, 135
Hi-Speed Compliance	10, 134, 135
Low-Speed	10, 134, 135
v 2.0 compliance	10
User	88
V	
View Certificate	123
W	
WAN	163
Web Flash Loading	119
Windows, adding printers	23
WINS	16, 127, 164
WINS Host Name Rules	127
Wizard	164