

**AXIS 210A/211A
Network Cameras
User's Manual**

About this Document

This manual is intended for administrators and users of the AXIS 210A/211A Network Camera and applies to firmware release 4.47. It includes instructions for using and managing the AXIS 210A/211A on your network. Previous experience of networking will be of use when using this product. Some knowledge of UNIX or Linux-based systems may also be beneficial, for developing shell scripts and applications. Later versions of this document will be posted to the Axis Website, as required. See also the product's online help, available via the Web-based interface.

Safety Notices Used In This Manual

Caution! - Indicates a potential hazard that can damage the product.

Important! - Indicates a hazard that can seriously impair operation.

Do not proceed beyond any of the above notices until you have fully understood the implications.

Intellectual Property Rights

Axis AB has intellectual property rights relating to technology embodied in the product described in this document. In particular, and without limitation, these intellectual property rights may include one or more of the patents listed at <http://www.axis.com/patent.htm> and one or more additional patents or pending patent applications in the US and other countries.

This product contains licensed third-party software. See the menu item "About" in the product's user interface for more information.

This product contains source code copyright Apple Computer, Inc., under the terms of Apple Public Source License 2.0 (see <http://www.opensource.apple.com/apsl/>). The source code is available from: <http://developer.apple.com/darwin/projects/bonjour/>

Legal Considerations

Video and audio surveillance can be prohibited by laws that vary from country to country. Check the laws in your local region before using this product for surveillance purposes. This product includes one (1) MPEG-4 decoder license. To purchase further licenses, contact your reseller.

Electromagnetic Compatibility (EMC)

This equipment generates, uses and can radiate radio frequency energy and, if not installed and used in accordance with the instructions, may cause harmful interference to radio communications. However, there is no guarantee that interference will not occur in a particular installation.

If this equipment does cause harmful interference to radio or television reception, which can be determined by turning the equipment off and on, the user is encouraged to try to correct the interference by one or more of the following measures: Re-orient or relocate the receiving antenna. Increase the separation between the equipment and receiver. Connect the equipment to an outlet on a different circuit to the receiver. Consult your dealer or an experienced radio/TV technician for help. Shielded (STP) network cables must be used with this unit to ensure compliance with EMC standards.

USA - This equipment has been tested and found to comply with the limits for a Class B computing device pursuant to Subpart B of Part 15 of FCC rules, which are designed to provide reasonable protection against such interference when operated in a commercial environment. Operation of this equipment in a residential area is likely to cause interference, in which case the user at his/her own expense will be required to take whatever measures may be required to correct the interference.

Europe -  This digital equipment fulfills the

requirements for radiated emission according to limit B of EN55022/1998, and the requirements for immunity according to EN55024/1998 residential, commercial, and light industry.

Japan - This is a class B product based on the standard of the Voluntary Control Council for Interference from Information Technology Equipment (VCCI:2003 Class B ITE). If this is used near a radio or television receiver in a domestic environment, it may cause radio interference. Install and use the equipment according to the instruction manual.

Australia - This electronic device meets the requirements of the Radio communications (Electromagnetic Compatibility) Standard 1998 AS/NZS 3548.

Canada - This Class B digital apparatus complies with Canadian ICES-003 B by compliance with EN55022: Class B.

Liability

Every care has been taken in the preparation of this manual. Please inform your local Axis office of any inaccuracies or omissions. Axis Communications AB cannot be held responsible for any technical or typographical errors and reserves the right to make changes to the product and manuals without prior notice. Axis Communications AB makes no warranty of any kind with regard to the material contained within this document, including, but not limited to, the implied warranties of merchantability and fitness for a particular purpose. Axis Communications AB shall not be liable nor responsible for incidental or consequential damages in connection with the furnishing, performance or use of this material.

Trademark Acknowledgments

Boa, Ethernet, Internet Explorer, Linux, Microsoft, Mozilla, Netscape Navigator, OS/2, UNIX, Windows, WWW are registered trademarks of the respective holders. Java and all Java-based trademarks and logos are trademarks or registered trademarks of Sun Microsystems, Inc. in the United States and other countries. Axis Communications AB is independent of Sun Microsystems Inc. UPnP™ is a certification mark of the UPnP™ Implementers Corporation.

Support

Should you require any technical assistance, please contact your Axis reseller. If your questions cannot be answered immediately, your reseller will forward your queries through the appropriate channels to ensure a rapid response. If you are connected to the Internet, you can:

- download user documentation and firmware updates
- find answers to resolved problems in the FAQ database. Search by product, category, or phrases
- report problems to Axis support by logging in to your private support area
- visit Axis Support at www.axis.com/techsup/

Safety Notice - Battery Replacement

The AXIS 210A/211A uses a 3.0V CR2032 Lithium battery as the power supply for its internal real-time clock (RTC). Under normal conditions this battery will last for a minimum of 5 years. Low battery power affects the operation of the RTC, causing it to reset at every power-up. A log message will appear when the battery needs replacing. The battery should not be replaced unless required!

If the battery does need replacing, please observe the following:

- Danger of Explosion if battery is incorrectly replaced
- Replace only with the same or equivalent battery, as recommended by the manufacturer.
- Dispose of used batteries according to the manufacturer's instructions.

AXIS 210A/211A User's Manual
Revision 3.0, Part No: 32532, July 2008
Copyright© Axis Communications AB, 2007-2008

Contents

- Introduction 5
 - Product features 5
 - Extra features - AXIS 211A 6
 - Overview 7
- Accessing the Camera 9
 - Accessing From a Browser 9
 - Setting the root password 10
 - Accessing from the Internet 10
- Video Streams 14
 - Video Stream Types 14
 - MPEG-4 protocols and communication methods 15
 - How to stream MPEG-4 15
 - AXIS Media Control 16
 - Other methods of accessing the video stream 16
 - Audio Stream Types 17
- The Setup link 19
- Video & Image settings 20
 - Image Settings 20
 - Overlay/Mask Settings 21
 - Advanced Settings 22
- Audio 26
 - Audio Settings 26
 - Advanced Audio Settings 28
- Live View Config 30
 - HTML Examples 33
 - External Video 33
 - Sequence Mode 34
- Event Configuration 36
 - Event Servers 36
 - Configuring Event Types 37
 - Camera Tampering 39
 - Motion Detection 39
 - Port Status 40
- System Options 41
 - Security 41

Date & Time	45
Ports & Devices.....	51
LED.....	51
Maintenance.....	51
Support	52
Advanced.....	52
Resetting to Factory Default Settings.....	53
Language.....	53
About.....	54
The I/O Terminal Connector	55
Technical Specifications.....	57
Troubleshooting	64
Glossary of Terms	70
Index	72

Introduction

This manual covers the following Axis Network Camera models:

- AXIS 210A
- AXIS 211A

All instructions and information in this manual are valid for both models unless otherwise stated.



AXIS 210A



AXIS 211A

Product features

The AXIS 210A/211A cameras are based on the AXIS ARTPEC-2 compression chip. Both models support the following features:

- Video streams from the camera available on the network as real-time, full frame rate, Motion JPEG and/or MPEG-4 video streams.
- Video Motion Detection - this can be used to trigger image uploads when there is activity in the video image.
- Scheduled image uploads.
- IP address filtering and multi-level password protection.
- Alarm input and output, which can be connected to various external devices, such as door sensors and alarm bells.
- Multiple video resolutions.
- Simultaneous access by up to 20 viewers when using Motion JPEG. If MPEG-4 multicast is used, the number of viewers is unlimited, but each viewer still needs a separate MPEG-4 license. One license is included in the product, additional licenses can be purchased separately.
- Privacy masking allows the concealment of parts of the image that should not be viewable. Up to three areas can be configured as masked areas.
- Built-in web server that provides full access to all features via a standard web browser.
- Built-in scripting tool that allows the creation of basic applications. For advanced functionality, the cameras can be accessed via VAPIX®, Axis Communications' powerful API (more info at www.axis.com/developer).

- (PoE) Power over Ethernet - supporting PoE network transformers conforming to IEEE 802.3af, the camera can be powered directly from the network cabling.
- Two-way audio - two-way audio capability for up to 20 simultaneous users. Audio communication can be bi-directional (full-duplex), push to talk (half-duplex) or in one direction only (simplex).
The AXIS 210A/211A has an integrated mono microphone, but there is also an audio input for connecting an external microphone or other source producing a line level signal. An active speaker with a built-in amplifier can be connected to the audio output to enable two-way communication.
- SNMP - the Simple Network Management Protocol allows the remote management of network devices.
- HTTPS - the AXIS 210A/211A supports encrypted browsing using HTTPS.

Extra features - AXIS 211A

DC-Iris

The AXIS 211A features a varifocal DC-Iris, which automatically regulates the amount of light entering the camera. Tele/wide and focus are adjusted manually with the aid of the pullers mounted on the lens.

Overview

AXIS 210A

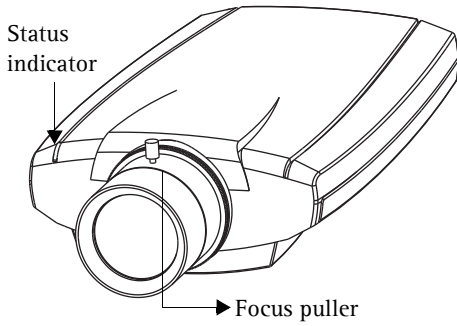

AXIS 211A

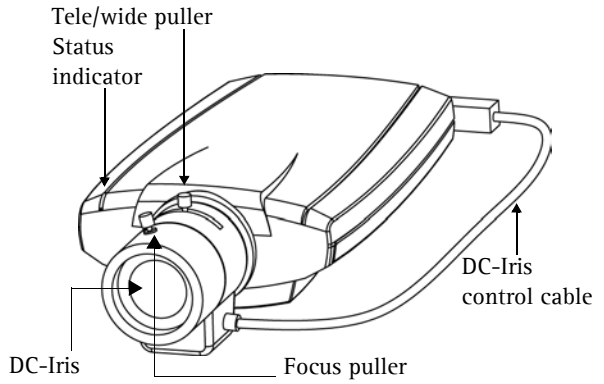

Underside

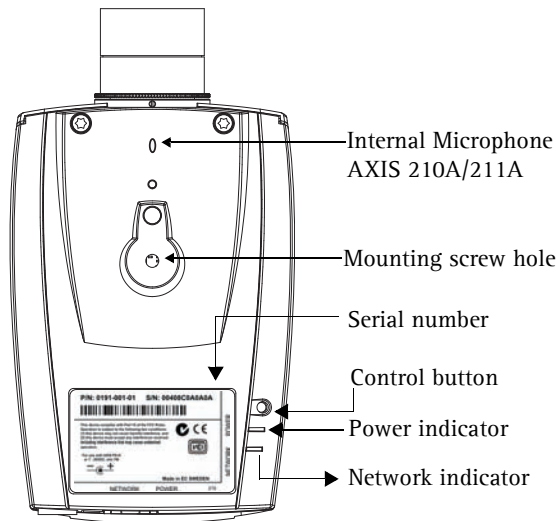

Rear panel

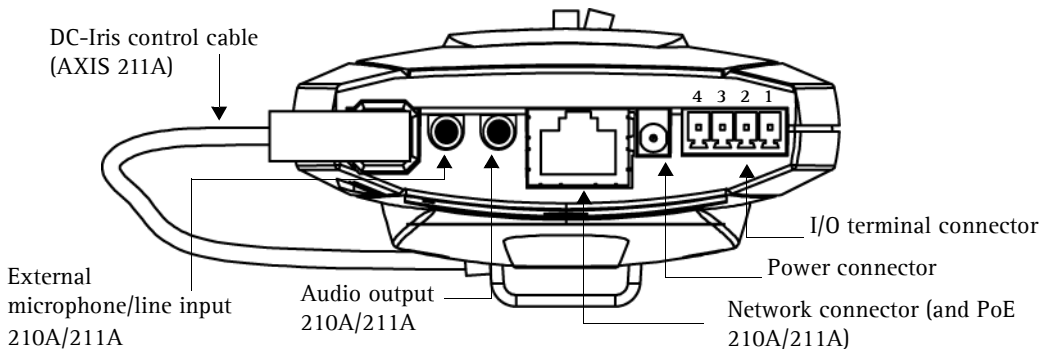

Power Connector - For connection of the PS-K power adapter (included).

I/O Terminal Connector - The I/O terminal connector provides the physical interface to one transistor output, one digital input and an auxiliary connection point for DC power. For more information, see *The I/O Terminal Connector*, on page 55.

Note: Depending on the product version of your AXIS 210A/211A, you will see one of two different types of I/O terminal connectors. See *The I/O Terminal Connector*, on page 55.

Network Connector - The camera connects to the network via a standard network connector. The camera detects the speed of the local network segment (10BaseT/100BaseTX Ethernet). This socket can also be used to power the AXIS 210A and the AXIS 211/211A via PoE (Power over Ethernet).

Audio Output - Audio output (line level), which can be connected to a public address (PA) system or an active speaker with a built-in amplifier. A pair of headphones can also be attached. A stereo connector must be used for the audio out.

External Microphone/Line Input - One 3.5mm input for a mono microphone, or for line-in mono signal (only the left channel is used from a stereo signal).

Serial Number - This number is used during installation.

Control Button - Press this button to install using the AXIS Internet Dynamic DNS Service (see page 46) or to restore the factory default settings, as described in *Resetting to Factory Default Settings*, on page 53.

LED Indicators

After completion of the startup and self test routines, the multi-colored Network, Status, and Power LED indicators show as follows:

Network	Amber	Steady for connection to 10 Mbit/s network. Flashes for network activity.
	Green	Steady for connection to 100 Mbit/s network. Flashes for network activity.
	Unlit	No wired network connection.
Status	Green	Shows steady green for normal operation. Can be configured to flash green at intervals whenever the camera is accessed.
	Unlit	When configured for "no flash" on camera access.
	Amber	Steady during startup, reset to factory default or when restoring settings.
	Red	Slow flash for failed firmware upgrade.
Power	Green	Normal operation.
	Amber	Flashes green/amber during firmware upgrade.

Accessing the Camera

Follow the instructions in the AXIS 210A/211A Installation Guide to install your camera.

The cameras can be accessed with most standard operating systems and browsers. The recommended browser is Internet Explorer for Windows, and Firefox with other operating systems. See also the *Technical Specifications*, on page 57.

Note: To view streaming video in Microsoft Internet Explorer for Windows, you may set your browser to allow the AXIS Media Control (AMC) to be installed on your computer. The first time an MPEG-4 video stream is accessed AMC also installs an MPEG-4 decoder for viewing the video streams. As a license is required for each instance of the decoder, the product administrator may have disabled the installation. If your computer restricts the use of additional software components, the cameras can be configured to use a Java applet for updating JPEG images. See the online help  for more information.

Accessing From a Browser

1. Start a browser (Internet Explorer, Firefox)
2. Enter the IP address or host name of the cameras in the **Location/Address** field of your browser.
3. If you are accessing the camera for the first time, see *Setting the root password*, on page 10. Otherwise enter your user name and password, as set by the administrator.
4. The camera's Live View is now displayed in your browser.



Note: The layout of the live view in the cameras may be customized to meet specific requirements. Some of the examples and functions featured here may differ from those displayed on your own Live View page.

Setting the root password

1. When accessing a camera for the first time, the 'Configure Root Password' dialog is displayed on the screen.

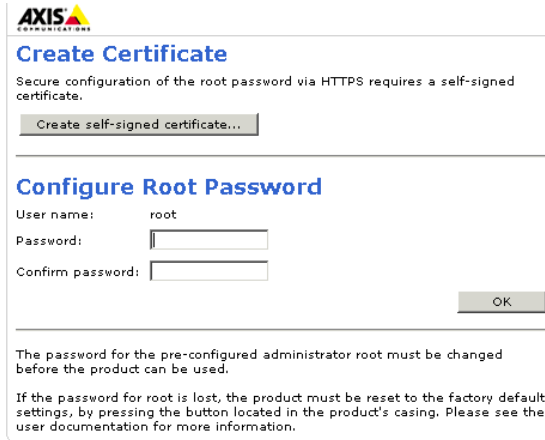

AXIS
COMMUNICATIONS

Create Certificate

Secure configuration of the root password via HTTPS requires a self-signed certificate.

Configure Root Password

User name:

Password:

Confirm password:

The password for the pre-configured administrator root must be changed before the product can be used.

If the password for root is lost, the product must be reset to the factory default settings, by pressing the button located in the product's casing. Please see the user documentation for more information.

Note: Before you enter your password at this point, you can secure configuration of the root password via HTTPS by creating a self-signed certificate. To do so, click the **Create self-signed certificate...** button in the Create Certificate window, and then proceed as follows.

2. Enter a password, and re-enter to confirm the spelling. Click **OK**.
3. The 'Enter Network Password' dialog appears. Enter the User name: **root**

Note: The default administrator user name **root** is permanent and cannot be deleted.

4. Enter the password as set in step 2 above, and click **OK**. If the password is lost, the cameras must be reset to the factory default settings. See page 53.
5. If required, click **Yes** to install the AXIS Media Control (AMC). You will need administrator rights on the computer to do this.

Accessing from the Internet

Once installed, a camera is accessible on your local network (LAN). To access the camera from the Internet you must configure your broadband router to allow incoming data traffic. For security reasons this is usually done on a specific port. Please refer to the documentation for your broadband router for further instructions.

For more information, please visit the AXIS Internet Dynamic DNS Service at www.axiscam.net or, for Technical notes on this and other topics, visit the Axis Support Web at www.axis.com/techsup

Focusing

To focus the AXIS 210A

Unscrew the focus puller on the lens. Adjust the focus as required. Re-tighten the focus puller.

To focus the AXIS 211A

Follow the instructions below.

1. From the **Basic Configuration** page in your browser, open the **Focus adjustment** page.
2. Set the DC-Iris to *Disabled* and click **Save**.
3. Unscrew the zoom puller on the lens by turning it anti-clockwise. Adjust the zoom setting as required. Re-tighten the zoom puller.
4. Unscrew the focus puller on the lens. Adjust the focus as required. Re-tighten.
5. From the Focus adjustment page, set the DC-Iris to *Enabled* and click **Save**.

Note: The DC-Iris should always be disabled while focusing the camera. This opens the iris to its maximum, which gives the smallest depth of field and thus the best conditions for correct focusing. When the focus is set with this method it is maintained in any light condition.

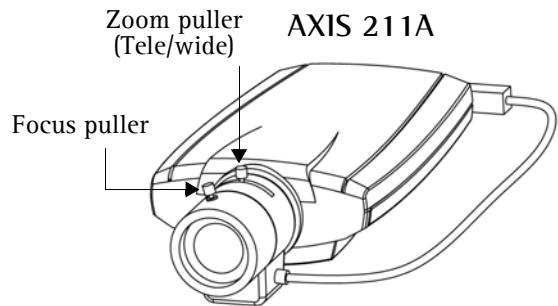
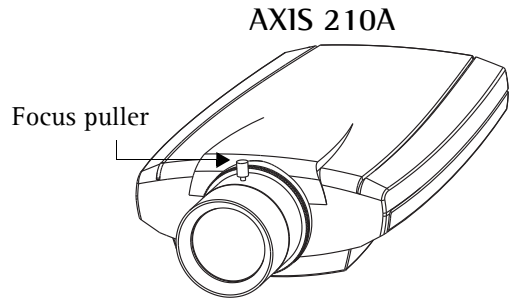

The Live View Page

You may not view all the buttons described below if the Live View page has been customized.

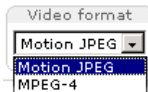
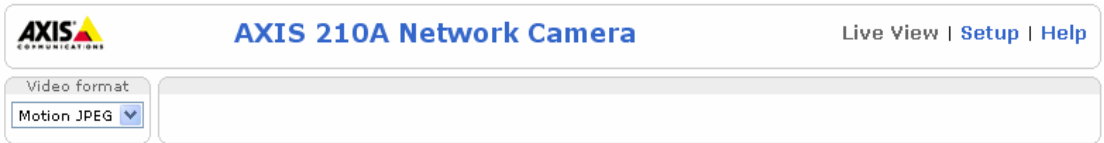

The Video Format drop-down list allows the video format on the Live View page to be temporarily changed.

The **Output** buttons control the output directly from the Live View page. These buttons are configured under **Setup > Live View Config > Layout**.



Pulse - click this button to activate the output for a defined period of time, e.g. switch on a light for 20 seconds.



Active/Inactive - click these buttons to manually start and stop a connected device, e.g. switch a light on/off.



These buttons start and stop the **Sequence Mode**. This mode is created in **Setup > Live View Config > Sequence mode**, and automatically displays the view from two or more video sources at set intervals.



From the **Source** list, select the desired external video source. Note that Sequence Mode must be stopped before selecting a source from this list.









The **Action** buttons can trigger an event directly from the Live View page. These are configured under **Setup > Live View Config > Layout**.

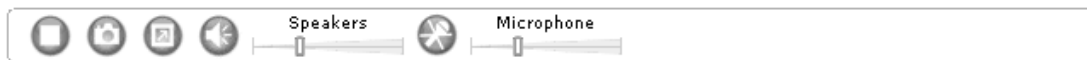

The **Snapshot** button saves a snapshot of the video image currently displayed. Right-click on the video image to save it in JPEG format on your computer. This button is primarily intended for use when the AMC viewer toolbar is not available.

The Live View toolbar displays the following buttons:



-   The **Play/Stop** button starts and stops the live video stream.
-  The **Snapshot** button saves a snapshot of the video image displayed. The Snapshot function and the target directory for saving snapshots can be configured from the AMC Control Applet in the Windows Control Panel (Internet Explorer for Windows only). See *AXIS Media Control*, on page 16.
-  Click the **View Full Screen** button to make the video image fill the entire screen area. Press Esc (Escape) on the computer keyboard to exit full screen, or right-click and select the option.
-  The record button is used to record the current video stream. The location where the image file is saved can be specified using the AMC control panel. To enable recording, Select **Live View Config > Viewer Settings > Enable recording button**.



Audio controls for AXIS 210A/211A

There are also controls for controlling the client computer’s speaker output and microphone sensitivity. These controls are only available when audio is enabled, see *Audio Settings*, on page 26. Push-to-talk settings are made in the AMC control panel, see *AXIS Media Control*, on page 16.

-  Click the **Speaker** and **Microphone** buttons to switch the sound off and on for the speaker and microphone, respectively.



Use the sliders to control the volume on the speaker and microphone. The volume can be set between 0 and 100. The buffer slider controls the size of the buffer for audio. A higher level will reduce audio break-up, but may introduce a noticeable lag in audio transmission. There are four settings - min, low, high, and max.

-   When using **Half-duplex** mode, this button toggles between allowing you to speak and listen. The first icon indicates that you can talk and the speaker attached to the camera will play your voice. The second indicates that you hear audio from the camera, but no audio is sent to any web clients.

When in **simplex** talk mode, the icon allows you to speak and is dimmed when you do not want other clients to receive any audio.

Video Streams

The AXIS 210A/211A provides several different image and video formats. You choose the type depending on your requirements and the properties of your network.

The Live View page in the AXIS 210A/211A provides access to Motion JPEG and MPEG-4 video streams, and to single JPEG images. Other applications and clients can also access these video streams/images directly, without going via the Live View page.

Video Stream Types

Motion JPEG

This format uses standard JPEG still images in the video stream. These images are then displayed and updated to create a stream that shows constantly updated motion.

The Motion JPEG stream uses considerable amounts of bandwidth, but also provides excellent image quality and access to every individual image contained in the stream.

Note also that multiple clients accessing Motion JPEG streams can use different image settings.

MPEG-4

This is a video compression standard that makes good use of bandwidth, and which can provide high-quality video streams at less than 1 Mbit/s.

The MPEG-4 standard provides scope for a large range of different coding tools for use by various applications in different situations, and the AXIS 210A/211A provides certain subsets of these tools. These are represented as Video object types, which are selected for use with different viewing clients. The supported video object types are:

- **Simple** - sets the coding type to H.263, as used by QuickTime™.
- **Advanced Simple** - sets the coding type to MPEG-4 Part 2, as used by AMC (AXIS Media Control).

When using MPEG-4 it is also possible to control the bit rate, which in turn allows control of bandwidth usage. CBR (Constant Bit Rate) is used to achieve a specific bit rate by varying the quality of the MPEG-4 stream. When using VBR (Variable Bit Rate), the quality of the video stream is kept as constant as possible, at the cost of a varying bit rate.

Notes: MPEG-4 is licensed technology. The AXIS 210A/211A includes one viewing client license. Installing additional unlicensed copies of the viewing client is prohibited. To purchase additional licenses, contact your Axis reseller.

All clients viewing the MPEG-4 stream must use the same set of coding tools.

MPEG-4 protocols and communication methods

To deliver live streaming video over IP networks, various combinations of transport protocols and broadcast methods are employed.

- RTP (Realtime Transport Protocol) is a protocol that allows programs to manage the real-time transmission of multimedia data, via unicast or multicast.
- RTSP (Real Time Streaming Protocol) serves as a control protocol, to negotiate which transport protocol to use for the stream. RTSP is thus used by a viewing client to start a unicast session, see below.
- UDP (User Datagram Protocol) is a communications protocol that offers limited service for exchanging data in a network that uses the Internet Protocol (IP). UDP is an alternative to the Transmission Control Protocol (TCP). The advantage of UDP is that it is not required to deliver all data and may drop network packets when there is network congestion. This is suitable for live video, as there is no point in re-transmitting old information that will not be displayed anyway.
- Unicasting is communication between a single sender and a single receiver over a network. The video stream goes independently to each user and each user gets their own stream. With unicasting that if one stream fails, it only affects one user.
- Multicast is bandwidth - conserving technology that reduces bandwidth usage by simultaneously delivering a single stream of information to multiple network recipients. This technology is used primarily on delimited networks (intranets), as users need uninterrupted data flow and should not rely on network routers.

How to stream MPEG-4

Deciding on the combination of protocols and methods to use depends on your viewing requirements, and on the properties of your network. Setting the preferred method(s) is done in the control applet for AMC, which is found in the Windows Control Panel. When this has been set, AMC will test all the selected methods in the specified order, until the first functioning one is found.

RTP+RTSP

This method (actually RTP over UDP and RTSP over TCP) should be your first consideration for live video, especially when it is important to always have an up-to-date video stream, even if some images do get dropped. This can be configured as multicast or unicast.

Multicasting provides the most efficient usage of bandwidth, especially when there are large numbers of clients viewing simultaneously. Note however, that a multicast broadcast cannot pass a network router unless the router is configured to allow this. It is thus not possible to multicast over the Internet.

Unicasting should be used for video-on-demand broadcasting, so that there is no video traffic on the network until a client connects and requests the stream. However, as more unicast clients connect, the traffic on the network will increase and may cause congestion. Although there is a maximum of 20 unicast viewers, note that all multicast users combined

count as 1 unicast viewer.

RTP/RTSP

This unicast method is RTP tunneled over RTSP. This can be used to exploit the fact that it is relatively simple to configure firewalls to allow RTSP traffic.

RTP/RTSP/HTTP or RTP/RTSP/HTTPS

These two methods can also be used to traverse firewalls. Firewalls are commonly configured to allow the HTTP protocol, thus allowing RTP to be tunneled.

AXIS Media Control

The recommended method of accessing live video from the AXIS 210A/211A is to use the AXIS Media Control (AMC) in Microsoft Internet Explorer for Windows. This ActiveX component is automatically installed on first use, after which it can be configured by opening the AMC Control Panel applet from the Windows Control Panel. Alternatively, right-click the video image in Internet Explorer.

Other methods of accessing the video stream

Video/images from the AXIS 210A/211A can also be accessed in the following ways:

- If supported by the client, the AXIS 210A/211A can use Motion JPEG server push to display video. This option maintains an open HTTP connection to the browser and sends data as and when required, for as long as required.
- As single JPEG images in a browser. Enter the path:

`http://<IP address>/axis-cgi/jpg/image.cgi?resolution=320x240`

- Windows Media Player. This requires AMC and the MPEG-4 decoder to be installed. The paths that can be used are listed below in the order of preference.
- Unicast via RTP: `axrtpu://<IP address>/mpeg4/media.amp`
- Unicast via RTSP: `axrtsp://<IP address>/mpeg4/media.amp`
- Unicast via RTSP, tunneled via HTTP: `axrtsphhttp://<IP address>/mpeg4/media.amp`
- Unicast via RTSP, tunneled via HTTPS: `axrtsphhttps://<IP address>/mpeg4/media.amp`
- Multicast: `axrtmp://<IP address>/mpeg4/media.amp`

Other MPEG-4 clients

Although it may be possible to use other clients to view the MPEG-4 stream, this is not guaranteed by Axis. For some other clients, such as QuickTime™ the Video Object Type must be set to *Simple*. It may also be necessary to adjust the advanced MPEG-4 settings.

To assess the video stream from QuickTime™ the following path can be used:

rtsp://<IP address>/mpeg4/media.amp

This path is for all supported methods, and the client negotiates with the AXIS 210A/211A to determine exactly which transport protocol to use.

Audio Stream Types

The stream types for audio are:

- G.711 - International standard for encoding wired-telephone audio. Uses PCM samples to compress audio where higher signal values are compressed more than lower values. In Axis products, this sets the coding type to μ -law 64 kbit/s.
- G.726 - Uses PCM samples to code the difference between samples (ADPCM). Reduces bandwidth without losing too much useful audio. In Axis products, this sets the coded bit rate to 24 or 32 kbit/s.

All stream types are ITU-T standards and operate on frequencies up to 4 kHz.

Audio transmission methods

The audio stream can be accessed in the Live View page via Motion JPEG or MPEG-4.

Using Motion JPEG

The basic audio transmission method used in conjunction with Motion JPEG video streaming is transmission over HTTP. The video and audio streams are not synchronized when using Motion JPEG, so the streams may be slightly out of sync. The latency in any stream should be low, but this depends on the network infrastructure.

Using MPEG-4

When using MPEG-4, audio is streamed using the same protocol as the video stream. When audio is transmitted using MPEG-4, the AXIS 210A/211A sends synchronization information along with the streams to the client performing the synchronization.

Note: Audio is streamed from the client to the server over HTTP when using Motion JPEG and MPEG-4.

Accessing the Audio Streams

In addition to accessing audio in the Live View page using AMC, audio from the AXIS 210A/211A can also be accessed in the following ways:

HTTP API

You can read about accessing audio for the other protocols through the VAPIX Application Programming Interface (API) at <http://www.axis.com/techsup>

QuickTime/Windows Media Player

It is possible to use QuickTime and Windows Media Player to listen to the audio stream using the same methods to access video streams.

The Setup link

This section describes how to configure the cameras, and is intended for product **Administrators**, who have unrestricted access to all options in the web interface, and **Operators** who have access to the settings for Video & Image, Audio, Live View Config and Event Configuration.

The camera is configured under **Setup** from a standard browser (see).

Accessing the Setup link

Follow the instructions below to access the Setup link from a browser.

1. Start your browser and enter the IP address or host name of the cameras in the location/address field.



2. The Live View page appears. Click **Setup** to display the Setup link.

Setup link
 ↓

 <p style="text-align: center;">AXIS 211A Network Camera</p> <p style="text-align: right;">Live View Setup Help</p> <ul style="list-style-type: none"> ▾ Basic Configuration <ul style="list-style-type: none"> Instructions 1. Users 2. TCP/IP 3. Date & Time 4. Video & Image 5. Focus 6. Audio ▸ Video & Image ▸ Audio ▸ Live View Config ▸ Event Configuration ▸ System Options Language About 	<h3 style="margin-top: 0;">Basic Configuration</h3> <p>Before using the AXIS 211A Network Camera, there are certain settings that should be made, most of which require Administrator access privileges. To quickly access these settings, use the numbered shortcuts to the left. All the settings are also available from the standard setup links in the menu.</p> <p>Focus adjustment is best performed from the shortcut shown here, although the DC-Iris setting is also available from the Advanced Image settings.</p> <p>Note that the only required setting is the IP address, which is set on the TCP/IP page. All other settings are optional. Please see the online help for more information.</p> <p>Firmware version: 4.47 MAC address: 00:40:8C:6B:3F:EC</p>
---	---

Video & Image settings

Given below are examples of features available in the AXIS 210A/211A. For details of each setting, please refer to the online help available from the web interface. Click  to access the online help.

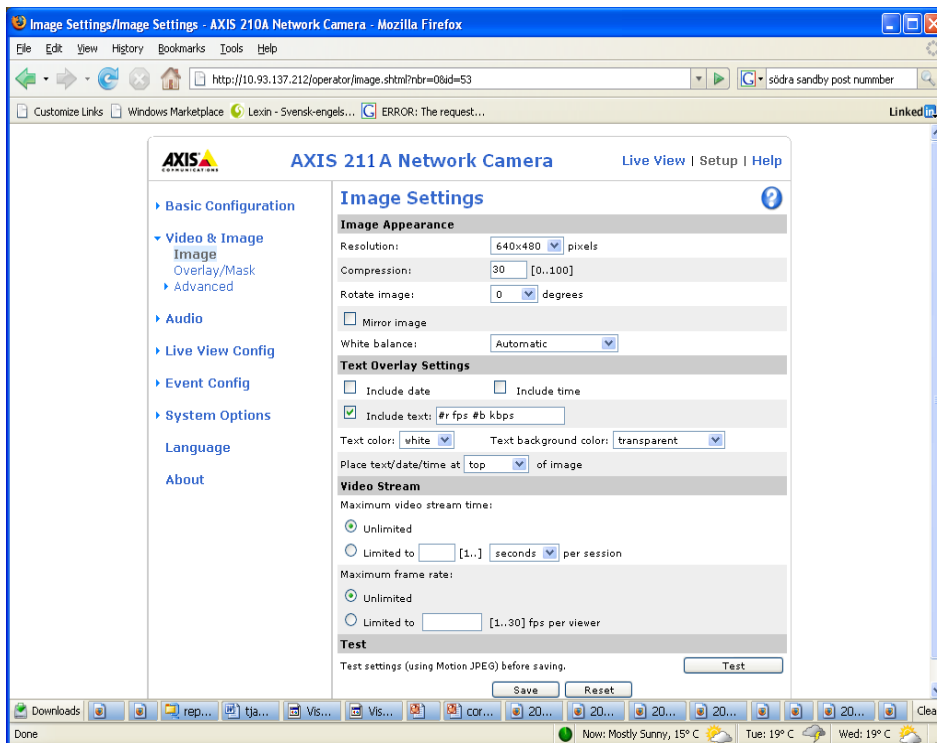



Image Settings

Image Appearance

Adjust these settings to optimize the video images according to your requirements.

All configuration of images and overlays affect the camera's overall performance, depending on how it is used and depending on the available bandwidth. Lower compression improves video image quality, but increases the bandwidth.

The image can be rotated, and adjusted in terms of resolution and compression. The image can also be mirrored; the white balance can be changed. Please see the online help  for further information on these settings.

Changes made to video image settings have immediate effect on the MPEG-4 stream; the Motion JPEG stream must be restarted before the settings take effect.

Text Overlay Settings

Include date, time and/or text of your choice to be viewed on the image. The color of the text may be set to white or black, while background color may be set to white, black, transparent or semitransparent. The position of the text is set either to the top or the bottom of the image. Click  for more information.

Video Stream

Define the maximum **video stream time** per session in seconds, minutes or hours. When the set time has expired, a new stream can be started by refreshing the page in the Web browser. For unlimited video stream time, set this value to 0. This setting is only applicable to Motion JPEG.

The **frame rate** allowed to each viewer can also be limited, to avoid bandwidth problems on the network.

Test

To preview the image before saving, click **Test**. Note that the preview image is in JPEG format, even though the settings are valid both for Motion JPEG and MPEG-4.

Overlay/Mask Settings

Overlay/Mask Type

When using an image overlay, select from the following options:

- Uploaded image as overlay - usually used to provide extra information in the video image.
- Configurable areas as privacy masks - up to three areas are used to conceal parts of the video image.

The difference between an overlay and a privacy mask is that a privacy mask cannot be bypassed by accessing the video stream with the help of the AXIS HTTP API, whereas an overlay can.

Selecting the overlay/mask type displays further settings available for the selected type. See the online help  for further information.

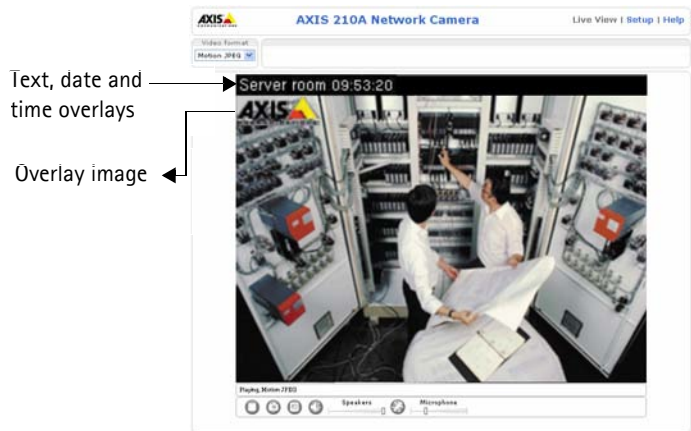

To upload and use an overlay

To upload an overlay image to the camera:

1. Select **Uploaded image as overlay** in the drop-down list for **Overlay/Mask Type**. New options appear.
2. Click the **Browse** button against **Upload own image**, and locate the image file on your computer or server.
3. Click the **Upload** button and follow the on-screen instructions.

To use an uploaded image

1. Select an uploaded image from the **Use image** drop-down list.
2. Place the image at the required location by entering the x and y coordinates.
3. Click **Save**.

Overlay image requirements

Image Formats	Image Size
<ul style="list-style-type: none"> • Windows 24-bit BMP (full color) • Windows 4-bit BMP (16 colors) 	The height and width of the overlay image in pixels must be exactly divisible by 4.

There are a number of limitations when using overlay images, such as the size and positioning of images. Please refer to the online help [?](#) for more information.

Configure area as privacy mask

The three configurable areas available for use as privacy masks show as solid areas of color in the image. These areas cannot be bypassed via VAPIX, Axis Communications' powerful API.

Enable the area(s) by checking the **Enable** box, and then set the width, height and color. Setting the coordinates x and y sets the position of the upper left corner of the area.

Advanced Settings

These settings help to fine-tune the video image. Note that the advanced settings available depend on the camera model.

Lighting Conditions

Color level, Brightness and Contrast - find the level that best suits your image needs by testing.

Exposure control - this setting is used to adapt to the amount/type of light being used.

Camera Settings

AXIS 211A Network Camera Live View | Setup | Help

Camera Settings ?

Lighting Conditions

Color level: [0..100]

Brightness: [0..100]

Contrast: [0..100]

Exposure control:

Low Light Behavior

Priority:

Max exposure time: s

Max gain: dB

View Image Settings

View image **after** saving.

Low Light Behavior

Low light conditions can reduce image quality and increase bandwidth usage. The Low Light Behavior settings define the balance between image quality and frame rate. During low light conditions, experiment with the Priority, Max exposure time, and Max gain settings until you achieve an acceptable image quality at the required frame rate.

Priority defines the balance between image quality and the frame rate. Higher image quality may reduce frame rate and increase motion blur. A prioritized frame rate may increase image noise.

Increasing the Max exposure time increases the quality of the image, but decreases the frame rate. There may also be increased motion blur.

Max gain, measured in decibels (dB), describes the amount of amplification applied to the visual information in the image. A high level of amplification provides viewable images in very low light, but increases image noise.

To prioritize image quality, choose Prioritize image quality from the Exposure priority drop-down box, and lower the Max gain. If this does not produce the desired results, increase the Max exposure time.

To instead prioritize frame rate, choose **Prioritize framerate** from the Priority drop-down box and reduce the Max exposure time. The image darkens considerably, but the frame rate is maintained. To increase image brightness increase Max gain, but this increases image noise.

Please refer to the online help [?](#) for more information.

MPEG-4 Settings

Tools for adjusting the MPEG-4 settings and for controlling the video bit rate.

The screenshot shows the 'MPEG-4 Settings' page for an 'AXIS 211A Network Camera'. The page has a navigation menu on the left with options like 'Basic Configuration', 'Video & Image', 'Audio', 'Live View Config', 'Event Config', 'System Options', 'Language', and 'About'. The main content area is titled 'MPEG-4 Settings' and contains several sections:

- Client Compatibility:** Video object type is set to 'Advanced Simple'. There is an unchecked checkbox for 'ISMA compliant'.
- GOV Settings:** Structure is set to 'IP'. Length is set to '8' with a range of '[1-150]'.
- Bit Rate Control:** Maximum bit rate is set to 'Unlimited'. Use is set to 'Variable bit rate'. Target bit rate is set to 'kbit/s'. Priority is set to 'None'.
- Video Stream:** Optimize the video stream for is set to 'frame rate'.
- View Image Settings:** View image after saving. There are 'Save' and 'Reset' buttons at the bottom.

The MPEG-4 standard provides many different tools for various applications in different situations. As most MPEG-4 clients do not support all of these tools, it is usual to instead define and use subsets for different clients or groups of clients. These settings allow you to define the type of viewing client to use.

Adjusting the maximum bit rate and setting it to a variable or constant is a good way of controlling the bandwidth used by the MPEG-4 video stream. For more information on these advanced settings, please see *Video Streams*, on page 14, and the online help .

MJPEG

Sometimes the image size is large due to low light or complex scenery. Adjusting the maximum frame size helps to control the bandwidth and storage used by the MJPEG video stream in these situations. Defining the frame size as Unlimited provides consistently good image quality at the expense of increased bandwidth and storage usage during low light. Limiting the frame size optimizes bandwidth and storage usage, but gives poor image quality. To prevent increased bandwidth and storage usage, the maximum frame size should be set to an optimal value.

AXIS Media Control

The AXIS Media Control (AMC) is installed automatically the first time the camera is accessed from a browser. The AMC control panel can be opened by right-clicking on the video image in the Live View web page. The AMC control panel can be used to configure various network, video and audio settings such as:

- Network reconnection strategy, multicast network interface, and MPEG-4 connection order
- MPEG-2 and MPEG-4 video processing settings and default video decoder setting
- Audio start settings and talk button options
- Video snapshot and recording settings
- Pan Tilt Zoom (PTZ) settings such as joy stick settings and PTZ mode settings

For more information, please see the AMC readme file included with AMC, or the *Axis Media Control (AMC) User Manual* available at www.axis.com

Audio

The AXIS 210A/211A can transmit audio to other clients using an external microphone and can play audio received from other clients by attaching a speaker. The Setup page for the AXIS 210A/211A has an additional menu item called **Audio**, which allows different audio configurations to be set up, such as full duplex, half duplex and simplex.

Note: The speaker attached to the audio output of the AXIS 210A/211A must have a built-in amplifier, such as PC speakers.

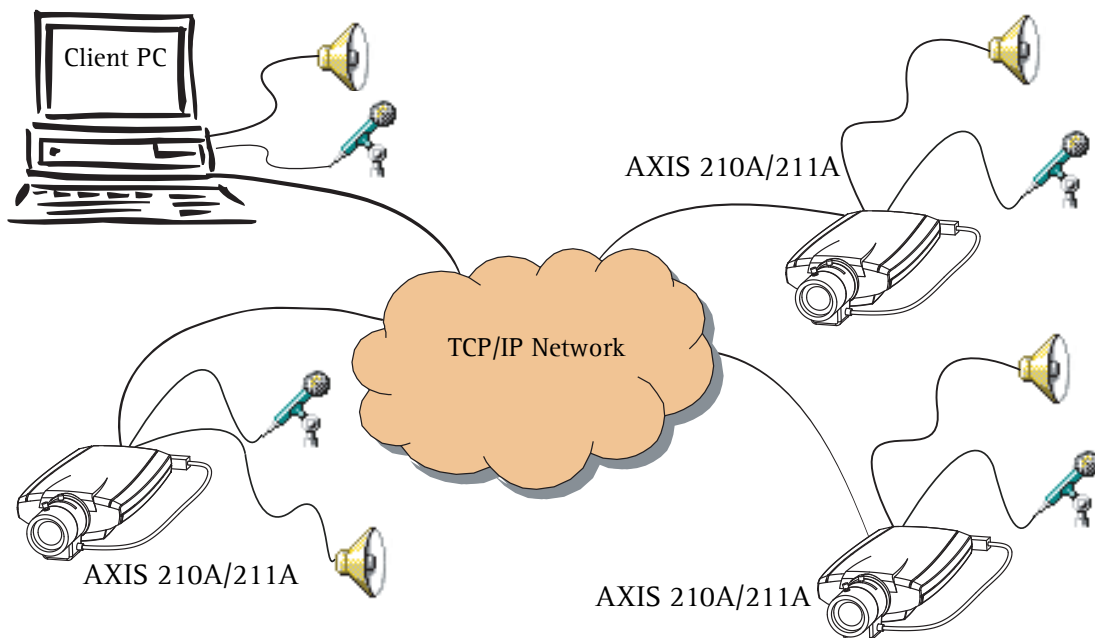

An example of a network using AXIS 210A/211A cameras to transmit audio and video across the network.

Audio Settings

This section describes how to configure basic audio settings for the AXIS 210A/211A, e.g. set the communication mode and adjust the sound levels in the microphone and speaker connected to the camera.

Enable Audio

Check this box to enable audio in the AXIS 210A/211A.

Audio Channels

There are two mono audio channels between the AXIS 210A/211A and other clients, one for receiving audio and one for transmitting audio. Each audio channel can be turned on or off, which means that there are four **audio mode** options that can be used.

Full-duplex mode means you can transmit and receive audio (talk and listen) at the same time, without having to use any of the controls. This is just like having a telephone conversation. The only controls you may wish to use are the mute buttons to turn off the sound, and the sliders, to adjust the input/output volume levels. This mode requires the client PC to have a sound card with full-duplex audio support. If your available bandwidth is 0.2 Mbit/s or less, using **Half-duplex** mode is recommended instead.

Half-duplex mode also transmits and receives audio in both directions, but only in one direction at a time. This means that you must select when to receive or transmit audio with the help of the push-to-talk button. To speak, press and hold the button (check that the microphone is not muted). When finished, release the button. You will now receive audio from the other end of the connection.

When using half-duplex, the **Send the sound from the active client to all other clients** option transmits the audio signal from the client that is talking to all the other clients.

Note that the push-to-talk button is configured from AMC; see *AXIS Media Control*, on page 24. It is also possible to configure the push-to-talk button so that it toggles between the speaking and listening modes. Half-Duplex mode is best if you only have limited bandwidth available.

When selecting the **Simplex - Network Camera speaker only** mode, the speaker connected to the camera plays audio, but no audio is transmitted from the camera to other web clients. This could be used to provide spoken instructions to a person seen in the camera. This mode requires you to use the push-to-talk button.

Simplex - Network Camera microphone only mode transmits audio only from the AXIS 210A/211A to web clients. It does not receive audio from any other web clients. This can be used in remote monitoring, and web attractions to provide live audio and video of a monitored situation.

Audio Input

Audio from an external microphone or a line source can be connected to the Line/Mic in jack of the AXIS 210A/211A. The audio source can be set to **Internal microphone**, **External microphone** or **Line**. If you are using a microphone, the **input sensitivity** can be set to **High** or **Low**. See *Technical Specifications*, on page 57 for the exact maximum levels.

The **Enable microphone power** option provides DC power for an external microphone. If using a small electret condenser microphone such as a clip-on microphone or a PC microphone, this option needs to be enabled.

To use a high impedance dynamic microphone, DC power should not be enabled. DC power will not harm the microphone, but if you are uncertain, try switching it off and on. The default value is DC power enabled. To use a professional microphone requiring 48V phantom power, you need an external power supply and must use a balanced-unbalanced converter (audio transformer) in between.

If there are problems with the sound input being too low or high, adjust the **input gain** for the microphone attached to the AXIS 210A/211A.

Audio Output

If the sound from the speaker is too low or high, adjust the **output gain** for the active speaker attached to the AXIS 210A/211A.

When satisfied with the settings, click **Save**, or click **Reset** to revert to the previously saved settings.

Advanced Audio Settings

The **Audio Quality Settings** allow you to fine-tune the internal or external microphone connected to the AXIS 210A/211A to suit your environment.

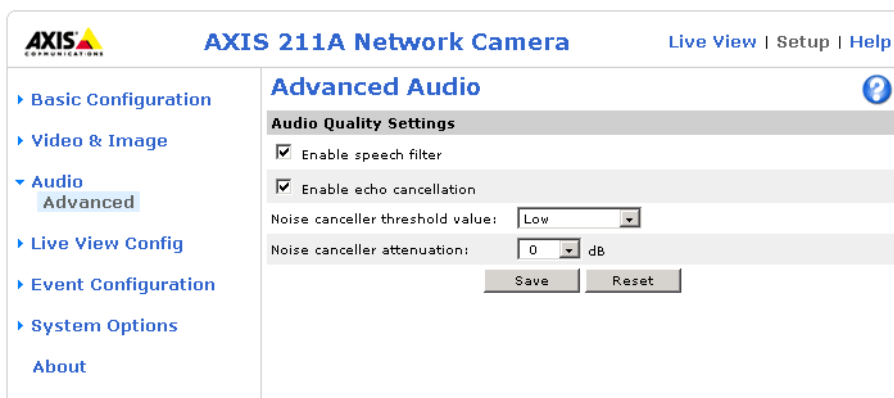

Enable speech filter improves the sound quality when the microphone is placed close to the person talking and can also help reduce background noise. The filter cuts the lowest and the highest frequencies. The bypass frequency range is approximately 250Hz to 3700Hz (measured at -10dB cut-off break points).

Enable echo cancellation - if audio from the speaker is captured by the microphone, this produces an echo. Enable this option to reduce acoustic echoing.

Noise canceling is a way of reducing the background noise when there is no useful audio present. A typical application could be that the camera is set up in a noisy environment, and you are only interested in hearing the sound from the AXIS 210A/211A when someone is speaking close to the microphone.

There are two adjustable parameters available for noise cancellation:

- Noise canceller threshold value
- Noise canceller attenuation

When the incoming sound is louder than the threshold it passes without being affected. When lower than the threshold, the incoming sound is reduced by a certain attenuation factor. The threshold level should be set higher than the background noise, but lower than the useful audio.

The **noise canceller threshold value** can be set to **High**, **Medium High**, **Medium low** or **Low**. A lower threshold allows most audio to pass; only the weakest background noise is reduced. A higher threshold makes the noise canceller act on even stronger background noise. At the maximum level - **High** - there is a risk of reducing useful audio as well.

There is thus always a trade-off between noise canceling and sound quality. In other words, increasing the **noise canceller attenuation** results in deterioration in sound quality. To adjust the threshold and attenuation to an optimum level, change the levels and then listen to the result.

AXIS Media Control (AMC)

The AMC control panel can also be used to configure various audio settings, such as start settings and talk button options. The AMC control panel can be opened by right-clicking on the video image in the Live View web page. Please see the readme file included in the tool for more information.

Live View Config

These are tools for deciding the layout of the camera's Live View page. The layout can be set in two ways:

- Use **Axis look** - the layout is unchanged.
- Use **custom settings** - modify the default Live View page with your own colors, images and so on. Click the **Configure** button and see below.

The other settings on this page concern other features to include, such as buttons and links. See page 32 for more information.

The Custom settings window

Click the **Configure** button in the Live View Layout page to access the Custom Settings window. Here you can customize the appearance of the default Live View page to suit your requirements, or you can upload and use your own home page. To upload your own files, click the **Upload/Remove** button and see the description below.

Upload Own Web Files

Your own background pictures, banners and logos can either be located externally on a network server, or they can be uploaded to the AXIS 210A/211A itself. Once uploaded, files are displayed in the Own drop-down lists. Follow these instructions to upload a file.

1. Click the **Upload/Remove** button in the Custom settings dialog.

AXIS 211A Network Camera Live View | Setup | Help

- Basic Configuration
- Video & Image
- Audio
- Live View Config**
 - Layout
 - HTML Examples
 - External Video
 - Sequence Mode
- Event Config
- System Options
 - Language
 - About

Live View Layout

Use Axis look
 Use custom settings **Configure...**

Default Video Format

Video format: Motion JPEG

Show video format selection

Default Viewer

Windows Internet Explorer: AMC (ActiveX)

Other Browsers: Server push

Note: QuickTime is only used with MPEG-4. Motion JPEG will be shown with AMC in Windows Internet Explorer and with server push in other browsers.

Viewer Settings

Show viewer toolbar

Enable MPEG-4 decoder installation

Enable recording button

Action Buttons

Show manual trigger button

Show snapshot button

User Defined Links

Show custom link 1 Use as: cgi link web link
 Name: Custom link 1 URL: http://

Show custom link 2 Use as: cgi link web link
 Name: Custom link 2 URL: http://

Show custom link 3 Use as: cgi link web link
 Name: Custom link 3 URL: http://

Show custom link 4 Use as: cgi link web link
 Name: Custom link 4 URL: http://

Save Reset

Custom Settings

Upload Own Web Files

To upload or remove your own web files, click **Upload/Remove...** (administrator only)

Modify the Axis Look

Background color: Default Own: White

Text color: Default Own: Black

Background picture: None Own: External: http://

Banner: None Own: External: http://

Banner link: None Own: http://

Logo: None Default Own: External: http://

Logo link: None Default Own: http://

Title: None Default Own: Title text above image

Description: None Default Own: Description text below image

Show setup link*

* **Caution!** Unchecking the box for *Show setup link* will remove the setup link from the product's Home Page. The Setup Tools will then only be accessible by entering the full setup address into the address/URL field of a browser. The setup address for this product is http://10.92.127.136/operator/basic.shtml.

Preview the page before saving Preview

Own Home Page

Use own home page

OK Cancel

2. Enter the path to the file on your computer or click the **Browse** button.
3. Select the user level for the uploaded file. This enables you to determine the pages that the users can view.
4. When the path is shown correctly in the text field, click the **Upload** button.

All uploaded files are shown in the list in the lower section of this dialog. To remove a file, check the box provided next to it and then click the **Remove** button.

Note: To use your own logo in the camera's web pages, the file must be in gif format and the file name must be in lower case e.g. mylogo.gif

Modify the Axis Look

Adjust the settings under **Modify the Axis look**, to change the background picture, banner, colors and so on.

To use your own file for a banner, first upload it (see the following page) or select **External** and enter the path to the file.

If you uncheck the box against **Show setup link** this removes the setup link from the camera's Home Page. You can then access the menus for setting up the camera by entering the full setup address into the address/URL field of a browser:

http://<IP address>/operator/basic.shtml

Own Home Page

From Live View Layout, select the radio button **Use custom settings** and click **Configure**.

Check the box **Use own home page** in the Custom Settings dialog, To use a previously uploaded web page (see above) as the default home page, select the page from the drop-down list and click **OK**.

Default Video Format

Select the default format to use on the Live View page. Checking the box against **Show video format selection** displays a drop-down list on the Live View page allowing you to temporarily change the format.

Note: It is also possible to view Motion JPEG when MPEG-4 is chosen as default and vice versa.

Default Viewer

When using *Microsoft Internet Explorer (IE)* for Windows, select your preferred method of viewing moving images. The options are:

- **AMC(ActiveX)**- This is the best choice for fast image updating in Internet Explorer, but might not be possible on computers that have restriction on the installation of additional software.
- **QuickTime** - For use with MPEG-4 only, select this to use the QuickTime plug-in for Microsoft Internet Explorer.
- **Java applet** - This alternative uses a Java applet to update the images in the browser.
- **Still Image** - Displays still images only. Hit the **Refresh** button in your browser to view a new image.

When using any other browser than Internet Explorer for Windows, select the appropriate method from the drop-down list for viewing images. The available options are similar to Internet Explorer except for **Server Push**. With this method, the camera maintains and controls an open HTTP connection to the browser and sends data as and when required for as long as required. Please see the online help  for more information.

Viewer settings

Checking the **Show viewer toolbar** option displays the viewer toolbar under the video stream in your browser.

By checking the Enable MPEG-4 decoder installation box, it is also possible for the Administrator to enable or disable the installation of the MPEG-4 decoder. This is used to prevent the installation of unlicensed copies. Further decoder licenses can be purchased from your Axis dealer. See also *AXIS Media Control*, on page 24.

Check the record button to record the current video stream. The location where the image file is saved can be specified using the AMC Control Panel.

Action Buttons

The manual trigger buttons can be used to manually trigger and stop an event from the Live View page. See *Event Configuration*, on page 36.

Enabling the display of the **Snapshot** button allows users to save a snapshot from the video stream by clicking the button. This button is mainly intended for use with browsers other than Internet Explorer for Windows, or when otherwise not using AXIS Media Control (AMC) to view the video stream. AMC for Internet Explorer provides its own snapshot button.

User Defined Links

Enter a descriptive name and enter the URL in the provided field.

Example

1. Check **Show Custom Link 1**
2. Enter a descriptive name, e.g. **My Website**
3. Check the radio button for **web link**.
4. Enter the web link: e.g. <http://www.example.com>
5. Click **Save**.



This link appears on the Live View page and opens the specified website.

User-defined CGI links can be used to issue advanced commands via the Axis HTTP API. For more information, see the Developer pages at www.axis.com/developer

HTML Examples

You can add live video from the cameras to your own web site. The camera can transmit a Motion JPEG or unicast MPEG-4 stream to up to 20 simultaneous connections, although an administrator can restrict this to fewer. If multicast MPEG-4 is used, the video stream will be available to an unlimited number of viewers connected to the parts of the network where multicast is enabled. Please note that a separate MPEG-4 license is required for each viewer.

Enter the **Video Format**, **Image type**, **Image size** and other settings to suit your Web page and click **Update**. The camera then generates the required source code for your configuration. Copy this code and paste it into your own Web page code.

External Video

The cameras can also display video images from other Axis network cameras and video servers, directly on the Live View page. These are known as **External Video** sources. These external video sources are available from the drop-down list on the Live View page.

Click the **Add** button to open the External Video Source Setup dialog, which is used to make all the necessary settings. Enter the IP address or host name of the external video source you wish to add. Depending on the external source, then select either MPEG-2, MPEG-4 or Motion JPEG as the type of video stream you want to receive.

Example of a path to an external video source:

```
http://192.168.0.125/axis-cgi/mjpeg/video.cgi
```

Sequence Mode

The Live View page can be configured to rotate through the internal and selected external video sources, in order, or at random.

Select the desired video sources and enter the time in seconds to display each source (up to 59 minutes). Click **Save**.

The Sequence buttons appear on the Live View page to enable the viewer to start and stop the sequence mode.

Please see the online help  for more information.

Event Configuration

An event in the camera happens when an **Event Type** is activated and results in certain actions. The event type is the set of parameters (or conditions) that define these actions. An example of an event type is the camera uploading images when an alarm occurs. Many event types use an **Event Server**, to upload images to - for example.

This section describes how to set up event servers and event types, that is how to configure cameras to perform certain actions in response to events occur.

Definitions

Event type	A set of parameters describing how and when the camera performs certain actions
Triggered Event - see page 37	An event that is started by some sort of signal, for example, an external device such as a door switch, motion detection, or system event.
Scheduled Event - see page 38	Pre-programmed time period(s) during which an event runs.
Action	This occurs when the event runs, for example, uploading of images to an FTP server, or email notification.

Event Servers

Event Servers can be used to receive uploaded image files and/or notification messages. To set up Event server connections in your cameras, go to **Setup > Event Configuration > Event Servers** and enter the required information for the required server type.

Server type	Purpose	Information required
FTP Server	<ul style="list-style-type: none"> Receives uploaded images 	<ul style="list-style-type: none"> Descriptive name of your choice Network address (IP address or host name) User Name and Password Upload path e.g. images/ Port number Use passive mode if there is a firewall between the camera and FTP server Use temporary file if your FTP server doesn't allow an existing file to be overwritten by a new file with the same name
HTTP Server	<ul style="list-style-type: none"> Receives notification messages Receives uploaded images 	<ul style="list-style-type: none"> Descriptive name of your choice URL (IP address or host name) User Name and Password Proxy address/Proxy port (if required) Proxy User Name and Password (if required)
TCP Server	<ul style="list-style-type: none"> Receives notification messages 	<ul style="list-style-type: none"> Descriptive name of your choice Network address (IP address or host name) User Name and Password Port number

For details on each setting, please see the online help  available from each web page.

When the setup is complete, the connection can be tested by clicking the **Test** button (the connection test takes approximately 10 seconds).

Configuring Event Types

An Event Type describes how and when the camera performs certain actions.

Example: If somebody passes in front of the camera and an event that uses motion detection has been configured to act on this, the camera can record and save images to an FTP server, and/or send a notification e-mail to a pre-configured e-mail address with a pre-configured message. Images can be sent as e-mail attachments.

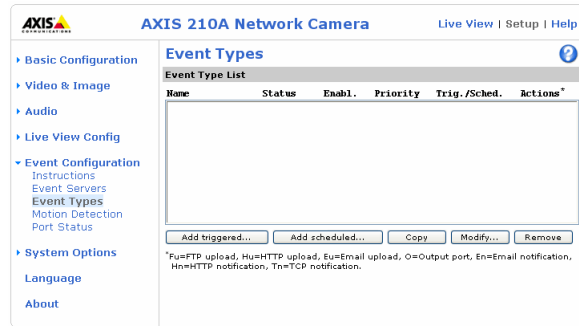

Triggered Event

A triggered event can be activated by:

- a push button connected to the camera's input port
- a manual action such as clicking the trigger button in the web interface
- detected movement in a configured motion detection window
- on restart (reboot) after power loss

How to set up a triggered event

This example describes how to set up the camera to upload images when the main door is opened:

1. Click **Add triggered** on the Event Types page.
2. Enter a descriptive **name** for the event, such as Main door open.
3. Set the **priority** - High, Normal or Low (see the online help).
4. Set **min time interval between triggers** - this is the minimum time period that the event type must wait after a trigger and before the next trigger. The interval commences as soon as the first trigger occurs. The shortest possible interval is 1 second and the longest is 23 hours, 59 minutes and 59 seconds. If you do not want to not use a minimum interval, set this option to 00:00:00
5. Set the **Respond to Trigger...** parameters to define when the event is active, such as only after office hours.
6. Select the trigger alternative from the **Triggered by...** drop-down list. For example select Input ports, for a sensor connected to the door.
7. Set the **When Triggered...** parameters, that is, define what the camera does if the main door is opened, such as upload images to an FTP server or send an e-mail notification.
8. Click **OK** to save the event in the Event Types list.

Please see the online help  for descriptions of each available option.

Note: Up to 10 event types can be configured in the cameras, and up to 3 of these can be configured to upload images. Files names can be formatted according to specific requirements. See File Naming Et Date/Time Formats online help.

Pre-trigger and Post-trigger buffers

This function is very useful when checking to see what happened immediately before and/or after a trigger, e.g. 5 seconds before and/or after a door was opened. Check the **Upload images** checkbox under **Event Types > Add Triggered... > Triggered by...** . All uploaded images are JPEG images.

Include pre-trigger buffer - images stored internally in the server from the time immediately preceding the trigger. Check the box to enable the pre-trigger buffer, enter the desired length of time and specify the required image frequency.

Include post-trigger buffer - contains images from the time immediately after the trigger. Configure as for pre-trigger.

Notes: Pre-trigger and Post-trigger buffers are lost if the connection to the event server fails.

The maximum length of the pre-/post-buffer depends on the video image size and selected frame rate.

If the pre- or post-buffer is too large for the camera's internal memory, the frame rate is reduced and individual images may be missing. If this occurs, an entry is created in the unit's log file.

Continue image upload (unbuffered) - enables the upload of video images for a fixed length of time. Specify the length of time for the uploaded recording, in seconds, minutes or hours, or for as long as the trigger is active. Finally, set the desired image frequency to the maximum (the maximum available) or to a specified frame rate. The frame rate is the best possible, but might not be as high as specified, especially if uploading via a slow connection.

Scheduled Event

A **Scheduled event** can be activated at preset times, in a repeating pattern on selected weekdays.

Configuration example:

1. Click **Add scheduled** on the **Event types** page.
2. Enter a descriptive name for the event, such as "Scheduled e-mail upload."
3. Set the **priority** (High, Normal or Low).
4. Set the **Activation Time** parameters (24h clock) defining when the event is active, e.g. start on Sundays at 13.00 for a duration of 12 hours.
5. Set the **When Activated...** parameters, defining what the camera does at the specified time, such as send uploaded images to an e-mail address.

6. Click **OK** to save the Event in the Event Types list.

Please see the online help  for descriptions of each available option.

Camera Tampering

The camera tampering application generates an alarm whenever the camera is repositioned, or when the lens is covered, sprayed or severely put out of focus.

The **Minimum duration** parameter defines the time that must elapse before the alarm goes off after the tampering. This helps prevent false alarms.

Check the **Alarm for dark images** box if there should be an alarm when the camera lens is sprayed and the image is dark.

Motion Detection

Motion detection is used to generate an alarm whenever movement occurs (or stops) in the video image. A total of 10 Include and/or Exclude windows can be configured.

- **Included windows** target specific areas within the whole video image
- **Excluded windows** define areas within an Include window that should be ignored (areas outside Include windows are automatically ignored)

Once configured, the motion detection windows appear in the list of available triggers, for triggering events. See “*How to set up a triggered event*” on page 37.

Note: Using the motion detection feature may decrease the camera's overall performance.

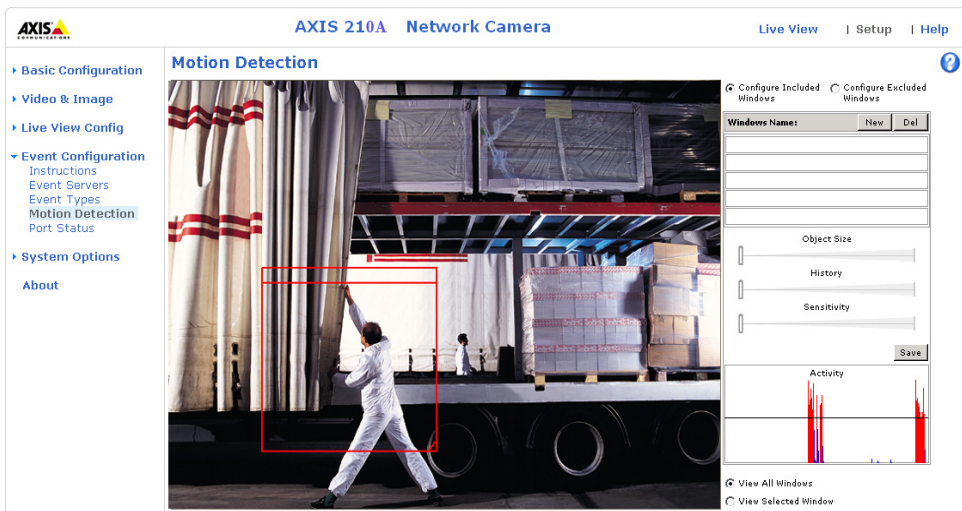

Configuring Motion Detection

1. Click **Motion Detection** in the **Event Configuration** menu.

2. Click the **Add Window** button.
3. Select the **Include** or **Exclude** option to define an Include or Exclude window, and enter a descriptive name in the field below.
4. Adjust the size (drag the bottom right-hand corner) and position (click on the text at the top and drag to the desired position).
5. Adjust the Object Size, History and Sensitivity profile sliders (see table below for details). Any detected motion within an active window is then indicated by red peaks in the Activity window (the active window has a red frame).
6. Click **Save**.

Note: To exclude parts of the Include window, click the Configure Excluded Windows button and position the Exclude window as required, within the Include window.

Please see the online help  for descriptions of each available option.

	Object Size	History	Sensitivity
High level	Only very large objects trigger motion detection	An object that appears in the region triggers the motion detection for a long period	Ordinary colored objects on ordinary backgrounds trigger the motion detection
Low level	Even very small objects trigger motion detection	An object that appears in the region triggers motion detection for only a very short period	Only very bright objects on a dark background trigger motion detection
Default value	Low	Medium to High	Medium to High

Examples:

- Avoid triggering on small objects in the video image by setting the **object size** level to high.
- To reduce the number of triggers if there is a lot of movement during a short period of time, select a high history level.
- To only detect flashing light, low **sensitivity** can be selected. In other cases, a high **sensitivity** level is recommended.

Port Status

Under **Event Configuration > Port Status** there is a list showing the status for the cameras's input and output. This is for the benefit of **Operators**, who have no access to the **System Options** section.

Example: If the Normal state for a push button connected to an input is set to **Open circuit** – as long as the button is not pushed, the state is **inactive**. If the button is pushed, the state of the input changes to **active**.

System Options

Security

User access control is enabled by default, when the administrator sets the root password on first access. An administrator can set up other users, by assigning user names and passwords. It is also possible to allow anonymous viewer login, which means that anybody may access the Live View page.

The AXIS 210A/211A Network Camera supports several methods of user authentication:

HTTP Basic Authentication - This authenticates the user by requesting a user name and a password. The exchange of network credentials is in simple base64 coding and is not encrypted.

HTTP Digest Authentication - This method also requests a user name and password, but the exchange of credentials is encrypted, which secures it against eavesdropping.

Users

User List - the user list displays the authorized users and user groups (levels):

Viewer	Provides the lowest level of access, which only allows access to the Live View page.
Operator	An operator can view the Live View page, create and modify event types and adjust certain other settings. Operators have no access to the System Options.
Administrator	An administrator has unrestricted access to all the setup options and can determine the registration of all other users.

User Settings - check the relevant checkboxes to enable:

- **Anonymous viewer login** - allows any viewer direct access to the Live View page.
- **Maximum number of simultaneous viewers limited to** - enter a value here to restrict the number of unicast viewers accessing the unit. This is useful if you need to save on bandwidth. (Note that all multicast viewers count as one viewer.)

IP Address Filtering

Enable IP Address Filtering: To allow or deny access to the AXIS 210A/211A Network Camera check the box **Enable IP address filtering**. Once enabled, the IP addresses in the list are allowed or denied access according to the choice made in the drop-down list **Allow/Deny the following IP addresses**.

The administrator can add up to 256 IP address entries to the list (a single entry can contain multiple IP addresses). The users from these IP addresses need to be specified in the user list with the appropriate access rights. This is done from **Setup > System Options > Security > Users**.

Referrals - To prevent unauthorized clients from including the video stream from the cameras into external Web pages, check the **Referrals** checkbox and enter the IP address or host name of the computer that hosts the Web pages with the included video stream. Several IP addresses/host names can be defined and are separated by semicolons (;). This option is only applicable to Motion JPEG video streams.

Notes: If the referrals feature is enabled and you wish to also allow normal access to the Live View page, the product's own IP address or host name must be added to the list of allowed referrers.

Restricting referrers has no effect on an MPEG-4 video stream. To restrict an MPEG-4 stream, IP address filtering must be enabled.

Restricting referrers is of greatest value when not using IP address filtering. If IP address filtering is used, then the allowed referrers are automatically restricted to those allowed IP addresses.

HTTPS

The AXIS 210A and the AXIS 211A both support encrypted browsing using HTTPS.

A **self-signed certificate** can be used until a Certificate Authority-issued certificate has been obtained. Click the **Create self-signed Certificate** button to install a self-signed certificate. Although self-signed certificates are free and offer some protection, true security is implemented after the installation of a signed certificate issued by a certificate authority.

A signed certificate can be obtained from an issuing Certificate Authority by clicking the **Create Certificate Request** button. When the signed certificate is returned, click the **Install signed certificate** button to import the certificate. The properties of any certificate request currently resident in the camera or installed can also be viewed by clicking the **Properties...** button. The HTTPS Connection Policy must also be set in the drop-down lists to enable HTTPS in the camera.

For more information, please refer to the online help. 

IEEE 802.1x

IEEE 802.1x is an IEEE standard for port-based Network Admission Control. It provides authentication to devices attached to a network port (wired or wireless), establishing a point-to-point connection, or, if authentication fails, preventing access on that port. 802.1x is based on EAP (Extensible Authentication Protocol).

In a 802.1x enabled network switch, clients equipped with the correct software can be authenticated and allowed or denied network access at the Ethernet level.

Clients and servers in an 802.1x network may need to authenticate each other by some means. In the Axis implementation this is done with the help of digital certificates provided by a **Certification Authority**. These are then validated by a third-party entity, such as a **RADIUS server**, examples of which are Free Radius and Microsoft Internet Authentication Service.

To perform the authentication, the RADIUS server uses various EAP methods/protocols, of which there are many. The one used in the Axis implementation is EAP-TLS (EAP-Transport Layer Security).

The AXIS network video device presents its certificate to the network switch, which in turn forwards this to the RADIUS server. The RADIUS server validates or rejects the certificate and responds to the switch, and sends its own certificate to the client for validation. The switch then allows or denies network access accordingly, on a preconfigured port.

The authentication process

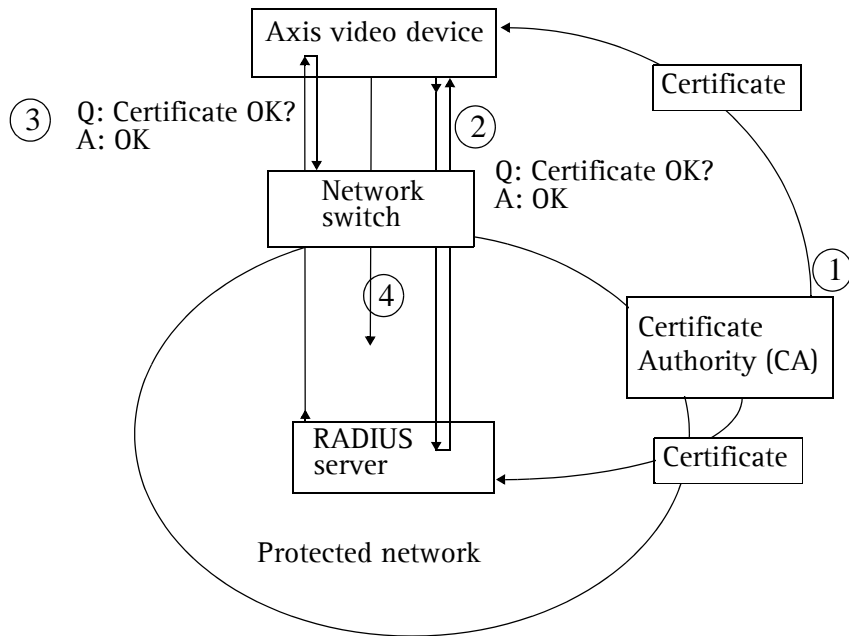

1. A CA server provides the required signed certificates.
2. The Axis video device requests access to the protected network at the network switch. The switch forwards the video device's CA certificate to the RADIUS server, which then replies to the switch.
3. The switch forwards the RADIUS server's CA certificate to the video device, which also replies to the switch.
4. The switch keeps track of all responses to the validation requests. If all certificates are validated, the Axis video device is allowed access to the protected network via a preconfigured port.

RADIUS

RADIUS (Remote Authentication Dial In User Service) is an AAA (Authentication, Authorization and Accounting) protocol for applications such as network access or IP mobility. It is intended to work in both local and roaming situations.

CA servers

In cryptography, a Certification Authority (CA) is an entity that provides signed digital certificates for use by other parties, and thus acts a trusted third party.

There are many commercial CAs that charge for their services. Institutions and governments may have their own CA, and there are free CAs available.

Date & Time

Current Server Time - displays the current date and time (24h clock). The time can be displayed in 12h clock format in the Overlay Images (see below).

New Server Time - select your time zone from the drop-down list. If you want the server clock to automatically adjust for daylight savings time, select the **Automatically adjust for daylight saving time changes**.

From the **Time Mode** section, select the preferred method to use for setting the time:

- **Synchronize with computer time** - sets the time from the clock on your computer.
- **Synchronize with NTP Server** - the camera obtains the time from an NTP server every 60 minutes. The NTP server's IP address or host name must be specified in the **TCP/IP Advanced Settings** - see page 46.
- **Set manually** - this option allows you to manually set the time and date.

Note: Note that if using a host name for the NTP server, a DNS server must be configured under **TCP/IP** settings. See **Network > Basic TCP/IP Settings** below.

Date & Time Format Used in Images - specify the formats for the date and time (12h or 24h) displayed in the Live View video streams.

Use the predefined formats or use your own custom date and time formats. See **Advanced File Naming & Date/Time Formats** in the help files  for information on how to create your own file formats.

Network

Basic TCP/IP Settings

IP Address Configuration

Your Axis network camera supports both IP version 4 and IP version 6. Both versions may be enabled simultaneously, and at least one version must always be enabled.

When using IPv4, the IP address can be set automatically via DHCP, or a static IP address can be set manually.

If IPv6 is enabled, your camera will receive an IP address according to the configuration in the network router.

There are also options for setting up notification of changes in the IP address, and for using the AXIS Internet Dynamic DNS Service. For more information on setting the IP address, please see the online help.

- Notes:**
- DHCP is a protocol for automatic IP address assignment on a network. IP address assignment via DHCP may lead to the situation where the IP address changes and you lose contact with the camera. Configure the options for notification of IP address change (under Services) to receive notification from the camera when the IP address changes.
 - Alternatively, if your DHCP server can update a DNS server, you can access the AXIS 210A/211A by host name which is always the same, regardless of the IP address.

Services

Options for notification of IP address change - if the IP address for the video server changes, e.g. automatically by DHCP, you can choose to be notified of the change. Click Settings... and enter the required information.

AXIS Internet Dynamic DNS Service - The AXIS Internet Dynamic DNS Service can provide your Axis product with its own URL (web address), which can then be used to access it over the Internet. The product can be unregistered from the service at any time. To do this click Settings... and follow the instructions. For more information, please refer to the online help.

Advanced TCP/IP Settings

DNS Configuration

DNS (Domain Name Service) provides the translation of host names to IP addresses on your network.

Obtain DNS server address via DHCP - automatically use the DNS server settings provided by the DHCP server. Click the View button to see the current settings.

Use the following DNS server address - enter the desired DNS server by specifying the following:

Domain name - enter the domain(s) to search for the host name used by the AXIS 210A/211A. Multiple domains can be separated by semicolons (;). The host name is always the first part of a Fully Qualified Domain Name, e.g. **myserver** is the host name in the Fully Qualified Domain Name **myserver.mycompany.com** where **mycompany.com** is the Domain name.

DNS servers - enter the IP addresses of the primary and secondary DNS servers.

Note: This is not mandatory with regard to secondary DNS servers.

NTP Configuration

The AXIS 210A/211A can obtain the correct time from an NTP server. The address for the NTP server can either be obtained via the DHCP server, or it can be entered manually.

Host Name Configuration

The AXIS 210A/211A can be accessed using a host name, instead of an IP address. The host name is usually the same as the assigned DNS Name.

For more information, please see the online help 

Link-Local IPv4 Address

This is enabled by default and assigns the AXIS 210A/211A an additional IP address for use with UPnP™. The AXIS 210A/211A can have both a Link-Local IP and a static/DHCP-supplied IP address at the same time - these will not affect each other.

HTTP

The default HTTP port number (80) can be changed to any port within the range 1024-65535. This is useful for simple security port mapping.

HTTPS

The default HTTPS port number (443) can be changed to any port within the range 1024-65535. HTTPS is used to provide encrypted web browsing.

NAT Traversal (port mapping) for IPv4

A broadband router allows devices on a private network (LAN) to share a single connection to the Internet. This is done by forwarding network traffic from the private network to the “outside” i.e. the Internet. Security on the private network (LAN) is increased since most broadband routers are pre-configured to stop any attempt to access the private network (LAN) from the public network/Internet.

Use NAT traversal when your AXIS 210A/211A is located on an intranet (LAN) and you wish to make it available from the other (WAN) side of a NAT router. With NAT traversal properly configured, all HTTP traffic to an external HTTP port in the NAT router is forwarded to the camera.

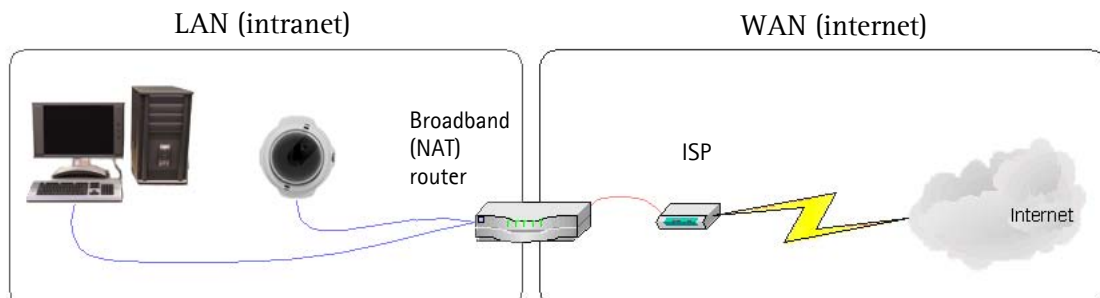

- Notes:**
- For NAT traversal to work, this must also be supported by the broadband router.
 - The broadband router has many different names: "NAT router", "Network router", "Internet Gateway", "Broadband sharing device" or "Home firewall" but the essential purpose of the device is the same.

Enable/Disable - When enabled, the AXIS 210A/211A attempts to configure port mapping in a NAT router on your network, using UPnP™. Note that UPnP™ must be enabled in the camera (see **System Options > Network > UPnP**).

Use manually selected NAT router - Select this option to manually select a NAT router and enter the IP address for the router in the field provided.

If a router is not manually specified, the AXIS 210A/211A automatically searches for NAT routers on your network. If more than one router is found, the default router is selected.

Alternative HTTP port - Select this option to manually define an external HTTP port. Enter the port number in the field provided. If no port is entered here a port number is automatically selected when NAT traversal is enabled.

- Notes:**
- An alternative HTTP port can be used/be active even if NAT traversal is disabled. This is useful if e.g. your NAT router does not support UPnP and you need to manually configure port forwarding in the NAT router.
 - If you attempt to manually enter a port that is already in use, another available port is automatically selected.
 - When the port is selected automatically it is displayed in this field. This can be changed by entering a new port number and clicking Save.

FTP

The FTP server running in the AXIS 210A/211A enables the upload of e.g. new firmware, user applications, etc. Check the box to enable the service.

RTSP

The RTSP protocol allows a connecting client to start an MPEG-4 stream. Enter the RTSP port number to use. The default setting is 554.

Network Traffic

The default setting is **Auto-negotiate** which means that the correct speed is automatically selected. If necessary, you can set the connection speed by selecting it from the drop-down list.

Maximum bandwidth - Specify, in Mbit/s or kbit/s, the maximum bandwidth the AXIS 210A/211A is allowed to use on your network. This is a useful function when connecting the camera to busy or heavily loaded networks. The default setting is **Unlimited**.

Note: When using MPEG-4 as the video format, remember that setting a maximum bandwidth value here may create problems for individual video streams if the maximum value is less than the sum of the bit rates set for the video streams.

For more information, please see the online help .

SOCKS

SOCKS is a network proxy protocol. The cameras can be configured to use a SOCKS server to reach networks on the other side of a firewall/proxy server. This functionality is useful if the camera is located on a local network behind a firewall, but notifications, uploads, and alarms need to be sent to a destination outside the local network (such as to the Internet).

QoS

Quality of Service (QoS) provides the means to guarantee a certain level of a specified resource to selected traffic on a network. Quality can be defined as a maintained level of bandwidth, low latency, no packet losses, and so on. The main benefits of a QoS-aware network can be summarized as:

- The ability to prioritize traffic and thus allow critical flows to be served before flows with lesser priority.
- Greater reliability in the network, thanks to the control of the amount of bandwidth an application may use, and thus control over bandwidth races between applications.

The QoS in Axis network video products marks the data packets for various types of network traffic originating from the product. This makes it possible for network routers and switches to e.g. reserve a fixed amount of bandwidth for these types of traffic. The following types of traffic are marked:

- live video
- live audio
- event/alarm traffic
- management network traffic.

QoS Settings

For each type of network traffic supported by your Axis network video product, enter a DSCP (Differentiated Services Codepoint) value. This value is used to mark the traffic's IP header. When the marked traffic reaches a network router or switch, the DSCP value in the IP header tells the router or switch which type of treatment to apply to this type of traffic, for example, how much bandwidth to reserve for it.

Note that DSCP values can be entered in decimal or hex form, but saved values are always shown in decimal.

For more information on Quality of Service, please see the Axis support web at www.axis.com/techsup

SMTP (email)

Enter the host names or addresses for your primary and secondary mail servers in the fields provided, to enable the sending of event and error e-mail messages from the camera to predefined addresses via SMTP.

SNMP

The Simple Network Management Protocol (SNMP) allows remote management of network devices. Depending on the level of security required, select the version of SNMP to use. The three levels of security are:

- SNMP V1 - includes no security.
- SNMP V2c - uses very simple security. The community name can be specified as a password for read or read/write access to all supported SNMP objects. The community is the the group of network devices using SNMP.
- SNMP V3 - provides encryption and secure passwords. HTTPS must be enabled.

UPnP™

The camera includes support for UPnP™. UPnP™ is enabled by default, and the network camera then is automatically detected by operating systems and clients that support this protocol. If also enabled on your computer, the camera is automatically detected and a new icon is added to “My Network Places.”

Note: UPnP must also be enabled on your Windows XP or ME computer. To do this, open the Control Panel from the Start Menu and select **Add/Remove Programs**. Select **Add/Remove Windows Components** and open the **Networking Services** section. Click **Details** and then select **UPnP** as the service to add.

RTP

These settings are for the IP addresses, port numbers, and Time-To-Live values to use for media streams in the MPEG-4 format. Only certain IP addresses and port numbers should be used for these streams. For more information, please see the online help.

Bonjour

Your Axis network camera includes support for Bonjour. When enabled, the camera is automatically detected by operating systems and clients that support this protocol.

Ports & Devices

I/O Ports - the pinout, interface support and the control and monitoring functions provided by this connector are described in *The I/O Terminal Connector*, on page 55.

LED

The Status indicator LED on the front of the camera can be set to flash at a configurable interval (or to not light up at all) whenever the unit is accessed. For a listing of all LED behavior, see page 8, or the online help.

Note: The LED does not flash when the stream is retrieved using MPEG-4 multicast.

Maintenance

- **Restart** - the camera is restarted without changing any of the settings. Use this method if the unit is not behaving as expected.
- **Restore** - the unit is restarted and most current settings are reset to factory default values. The settings that are reset are as follows:
 - the boot protocol (DHCP or static)
 - the static IP address
 - the default router
 - the subnet mask

- the system time
- **Default** - the default button should be used with caution. Pressing this returns all of the camera's settings (including the IP address) to the factory default values.

Upgrade Server - See *Upgrading the Firmware*, on page 64.

Backup - click this button to take a backup of all the parameters, and any user-defined script. You can then return to the previous settings, if settings are changed and there is unexpected behavior.

Restore - click the **Browse** button to locate the saved backup file (see above) and then click the **Restore** button. The settings are restored to the previous configuration.

Note: Backup and Restore can only be used on the same unit running the same firmware. This feature is not intended for the configuration of multiple units or for firmware upgrades.

Support

The **Support Overview** page provides valuable information on troubleshooting and contact information, should you require technical assistance.

System Overview - is a quick look over the camera's status and settings. Information be found here includes the camera's **Firmware version**, **IP address**, **Security**, **Event** and **Image Settings and Recent Log Items**. Many of the captions are also links to the proper **Setup page** to conveniently make adjustments in the cameras settings.

Logs & Reports - when contacting Axis support, please be sure to provide a valid **Server Report** with your query.

Information

The **Log file**, the **Server Report** and the **Parameter List** all provide valuable information for troubleshooting and when contacting Axis support.

Configuration

Log Level for Log Files - from the drop-down list, select the level of information to be added to the Log file

Log Level for E-mail - select the level of information from the drop-down list to send as e-mail and enter the destination e-mail address.

Advanced

Scripting - this an advanced function that provides the means for customizing and using scripts.

Caution!

The scripting function is a very powerful tool. Improper use may cause unexpected behavior or even loss of contact with the unit. If a script does cause problems, reset the unit to its factory default settings (in which case, a previously saved backup file is useful for returning the unit to its latest configuration). **Axis recommends that you do not use this function unless you fully understand the consequences.** Axis support provides no assistance for customized scripts.

For more information, please visit the Developer pages at www.axis.com/developer

Plain Config - this function is for the advanced user with previous experience of configuring Axis cameras. All parameters can be set and modified from this page. Help is available via the links on the standard setup pages.

Resetting to Factory Default Settings

To reset the cameras to the original factory default settings, go to the **System Options > Maintenance** web page (as described in *Maintenance*, on page 51) or use the **Control button** on the side of the camera (see page 7) as described below:

Using the Control Button

To reset the cameras to the factory default settings using the Control Button:

1. Disconnect the power adapter, or the network cable if using PoE (AXIS 210A/AXIS 211A only).
2. Press and hold the Control button while reconnecting the power.
3. Keep the Control button pressed until the **Status Indicator** color changes to amber (this may take up to 15 seconds).
4. Release the Control button.
5. When the Status Indicator changes to green (which may take up to 1 minute), the process is complete and the cameras has been reset. The unit now has the default IP address 192.168.0.90.

Note: For other methods of setting the IP address, please refer to the product's Installation Guide that accompanies the product, or download a copy from www.axis.com

Language

The language used in the AXIS 210A/AXIS 211A can be changed so that all web pages appear in the selected language.

You need to upload the language file first, before you can select it. Click the **Browse** button and locate the language file. Click **Upload Language** to upload the file. The new language now appears in the list under **Select Language**. Select the language and click **Save** to save the selection.

About

Here you can find basic information about your network camera. You can also view third party software licenses.

The I/O Terminal Connector

Pinout and Interface

The 4-pin I/O terminal connector provides the interface to:

- 1 transistor output
- 1 digital input
- auxiliary power and GND

The terminal connector is used in applications for motion detection, event triggering, time lapse recording, alarm notification via e-mail, image storage to FTP locations, and so on.

- **Input** - for connecting a push button for example. If the push button is pressed, the state changes and the input becomes active (shown under Event Configuration > Port Status).
- **Output** - connects an alarm device that can be activated by Output buttons on the Live View page, or by an Event Type. The output shows as active (Event Configuration > Port Status) if the alarm device is activated.

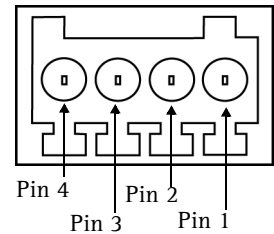
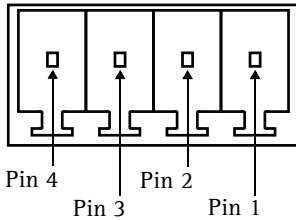

Pin	Function	Description
4	Transistor Output	With a maximum load of 100mA and a maximum voltage of 24V DC, this output has an open-collector NPN transistor with the emitter connected to pin 1 (GND). If used with an external relay, a diode must be connected in parallel with the load, for protection against voltage transients.
3	Digital Input	Connect to GND to activate, or leave floating (or unconnected) to deactivate.
2	Auxiliary DC Power Input	7-20 VDC/max 5W. Electrically connected in parallel with the PS-K power connector, this pin provides an auxiliary connector for mains power to the unit. If the unit is powered via this pin, a fuse should be used (rating: 1A Slow). This pin can also be used to power auxiliary equipment, max 100mA, but note that this is <u>not</u> possible when the AXIS 210A/AXIS 211/211A is powered by PoE.
1	GND	Ground

Connect input/output devices to the terminal connector as follows:

1. Loosen the corresponding screw on top of the pin (see above for the correct pin).
2. Push the cable into the connector and secure it by fastening the screw.

- Once devices are connected, connect the terminal connector to the camera, making sure that all cables are securely fastened.

Schematic Diagram - Terminal Connectors

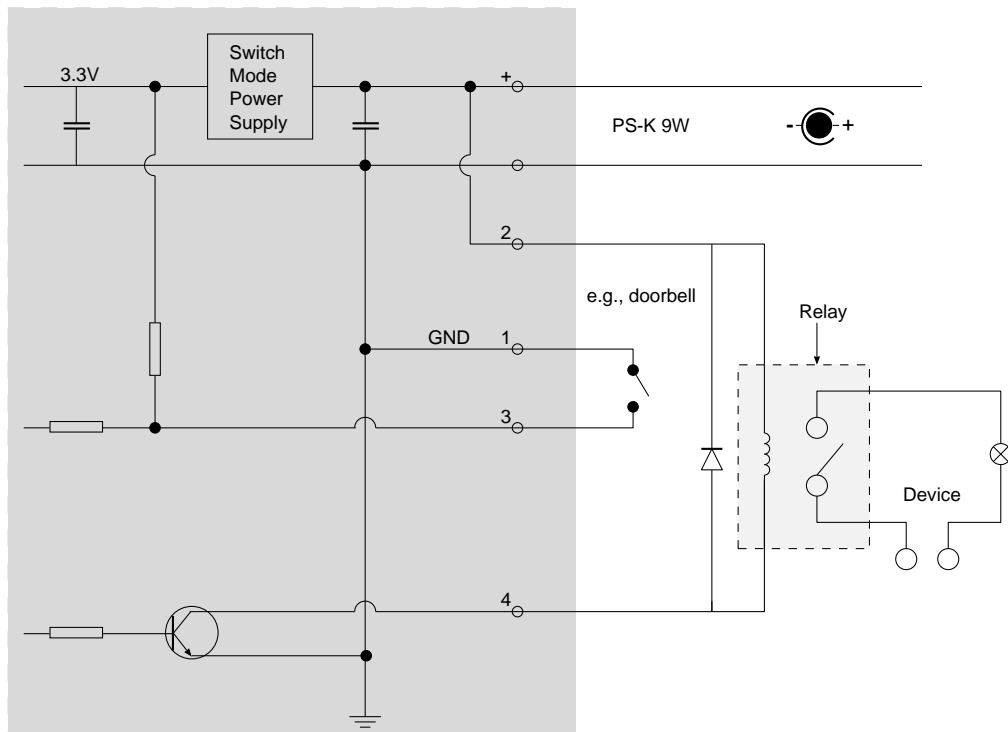

Technical Specifications

Item	Specification
Models	<ul style="list-style-type: none"> • AXIS 210A: indoor use only • AXIS 211A: varifocal DC-Iris; indoor/outdoor
Image sensor	<ul style="list-style-type: none"> • 1/4" Sony Wfine progressive scan RGB CCD
Lens	<ul style="list-style-type: none"> • AXIS 210A: 4.0 mm, F1.2, fixed iris, CS mount • AXIS 211A: 3.0 - 8.0 mm, F1.0, DC-iris, CS mount
Angle of view	<ul style="list-style-type: none"> • AXIS 210A: 48° horizontal • AXIS 211A: 27°-67° horizontal
Minimum illumination	<ul style="list-style-type: none"> • AXIS 210A: 1.0 lux, F1.2 • AXIS 211A: 0,75 lux, F1.0
Video compression	<ul style="list-style-type: none"> • Motion JPEG • MPEG-4 Part 2 (ISO/IEC 14496-2), Profiles: ASP and SP
Resolutions	16 resolutions from 640 x 480 to 160 x 120 via API, 5 selections via configuration web page
Frame rate	<ul style="list-style-type: none"> • Motion JPEG: <ul style="list-style-type: none"> Up to 30 fps in all resolutions • MPEG-4: <ul style="list-style-type: none"> Up to 25 fps at 640x480 Up to 30 fps at 480x360 or lower
Video streaming	<ul style="list-style-type: none"> • Simultaneous Motion JPEG and MPEG-4 • Controllable frame rate and bandwidth • Constant and variable bit rate (MPEG-4)
Image settings	<ul style="list-style-type: none"> • Compression levels: 11 (Motion JPEG)/23 (MPEG-4) • Rotation: 90°, 180°, 270° • Mirroring • Configurable color level, brightness, contrast, exposure, white balance, fine tuning of behavior at low light • Overlay capabilities: time, date, privacy mask, text or image
Shutter time	<ul style="list-style-type: none"> • 1/12500 to 2 sec

Item	Specification
Audio	<ul style="list-style-type: none"> • Two-way (full or half duplex), one-way or audio off. • Encoding formats (selected under System Options): <ul style="list-style-type: none"> ADPCM format at 24kbps, 8 kHz sampling (G.726 - select G723 from drop-down list) ADPCM format at 32kbps, 8 kHz sampling (G.726 - select G721 from drop-down list) PCM μ-law format at 64kbps, 8 kHz sampling (G.711 default) • Built-in microphone, external microphone input or line input. Mono audio output (line level) connects to PA system or active speaker with built-in amplifier. • External audio input: Single 3.5mm input for a mono microphone, or line-in mono signal (left channel is used from a stereo signal). • Microphone input sensitivity: High = max -38 dBu (27 mVpp), Low = max -18 dBu (275 mVpp) • Line input - max: 11.2 dBu (8.0 Vpp); Line output - max: 3Vpp • DC power through input connector for external microphones supported. • Audio output (line level) connects to PA system or active speaker with built-in amplifier. Headphones can also be connected. A stereo connector must be used for the audio out. • Audio output: max 3.0 Vpp (+2.7dBu) • Audio output impedance: min 38 ohm; max 10 ohm • Audio input impedance: 7kohm • Audio compression: G.711 PCM 64kbit/s, G.726 ADPCM 32 or 24 kbit/s
Security	<ul style="list-style-type: none"> • Multiple user access levels with password protection • IP address filtering • HTTPS encryption • Network access control IEEE801.1X • User access log
Users	<ul style="list-style-type: none"> • 20 simultaneous users • Unlimited users using multicast (MPEG-4)
Language support (Web interface)	<ul style="list-style-type: none"> • English. Downloadable language files for French, German, Italian, Japanese and Spanish are available at www.axis.com/techsup. • Other language files may also be available
Alarm and event management	<ul style="list-style-type: none"> • Events triggered by built-in motion detection, audio detection, active tampering alarm, external inputs or according to a schedule. • Image upload over FTP, email and HTTP Notification over TCP, email, HTTP and external outputs. • Pre- and post alarm buffer: up to 9 MB (up to 5 min of 320x240 video at 4 frames per sec).
Connectors	<ul style="list-style-type: none"> • RJ-45 for Ethernet 10BaseT/100BaseTX • Terminal block for 1 alarm input, 1 output and alternative power connection • 3.5 mm jack for Mic in (max 270mVpp) or Line mono input (3.2Vpp) • 3.5 mm jack for Line mono output (3.0Vpp) • Output impedance: 32 ohm
Casing	Plastic

Item	Specification
Processors and memory	<ul style="list-style-type: none"> • CPU: ETRAX 100LX 32bit • Video processing and compression: ARTPEC-2 • RAM: 32 MB • Flash: 8 MB • Battery backed up real-time clock
Power	<ul style="list-style-type: none"> • 7-20 V DC max 7 W • PoE IEEE802.3af Class 2
Operating conditions	<ul style="list-style-type: none"> • 5 - 45 °C (41 - 113 °F), humidity 20 - 80% RH
Installation, management and maintenance	<ul style="list-style-type: none"> • AXIS Camera Management tool on CD and web-based configuration • Configuration of backup and restore • Firmware upgrades over HTTP or FTP, firmware available at www.axis.com
Video access from Web browser	<ul style="list-style-type: none"> • Camera live view, • Video recording to file (ASF), • Sequence tour for up to 20 external Axis video sources, • Customizable HTML pages
Minimum web browsing requirements	<ul style="list-style-type: none"> • Pentium III CPU 500 MHz or higher, or equivalent AMD • 128 MB RAM • AGP graphics card 32 MB RAM, Direct Draw • Windows XP, 2000, 2003 Server • DirectX 9.0 or later • Internet Explorer 6.x or later • For other operating systems and browsers see www.axis.com/techsup
System integration support	<ul style="list-style-type: none"> • Open API for application integration including AXIS VAPIX API*, AXIS Media Control SDK*, event trigger data in video stream • Quality of Service (QoS) Layer 3, DiffServ Model • Embedded Linux operating system <p>* Available at www.axis.com</p>
Supported protocols	<ul style="list-style-type: none"> • IPv4/v6, HTTP with Digest Authentication, HTTPS, SSL/TLS*, TCP, QoS, SNMPv1/v2c/v3 (MIB-II), RTSP, RTP, UDP, IGMP, RTCP, SMTP, FTP, ICMP DHCP, UPnP, Bonjour, ARP, DNS, DynDNS, SOCKS, IEEE802.1X. More information on protocol usage available at www.axis.com <p>*This product includes software developed by the Open SSL Project for use in the Open SSL Tool kit (www.openssl.org)</p>
Included accessories	<ul style="list-style-type: none"> • Power supply 9 V DC • Stand • Connector kit • Installation Guide • CD with installation tool, software and User's Manual • MPEG-4 licenses (1 encoder, 1 decoder) • MPEG-4 decoder (Windows)
Video management software (not incl.)	<ul style="list-style-type: none"> • AXIS Camera Station - Surveillance application for viewing, recording and archiving up to 50 cameras <p>See www.axis.com/partner/adp_partners.htm for more software applications via partners</p>

Item	Specification
Accessories (not incl.)	<ul style="list-style-type: none"> • Housings for adverse indoor/outdoor environments • Power over Ethernet midspans • AXIS 292 Network Video Decoder • MPEG-4 Decoder multi-user license pack.
Approvals	<ul style="list-style-type: none"> • EN 55022 Class B • EN 61000-3-2 • EN 61000-3-3 • EN 55024 • FCC Part 15 Subpart B Class B • ICES-003 Class B • VCCI Class B • C-tick AS/NZS 3548 • EN 60950 • Power supply: EN 60950, UL, cUL
Dimensions (HxWxD) and weight	<ul style="list-style-type: none"> • AXIS 210A: 38 x 88 x 157 mm (1.5" x 3.4" x 6.2") • AXIS 211A: 38 x 95 x 178 mm (1.5" x 3.7" x 7.0") • 270 g (0.6 lb) excl. power supply

General performance considerations

When setting up your system, it is important to consider how various settings and situations affect performance. Some factors affect the amount of bandwidth (the bit rate) required, others can affect the frame rate, and some affect both. If the load on the CPU reaches its maximum, this also affects the frame rate.

The following factors are among the most important to consider:

- High image resolutions and/or lower compression levels result in larger images. Bandwidth affected.
- Access by large numbers of Motion JPEG and/or unicast MPEG-4 clients. Bandwidth affected.
- Simultaneous viewing of different streams (resolution, compression, etc.) by different clients. Frame rate and bandwidth affected.
- Accessing both Motion JPEG and MPEG-4 video streams simultaneously. Frame rate and bandwidth affected.
- Heavy usage of event settings affects the camera's CPU load. Frame rate affected.
- Enabled motion detection. Frame rate and bandwidth affected.
- Heavy network utilization due to poor infrastructure. Bandwidth affected
- Viewing on poorly performing client PC's lowers perceived performance. Frame rate affected.

Optimizing your system

To see the bandwidth and frame rate currently required by the video stream, the AXIS 210A/211A provides a tool that can be used to display these values directly in the video image.

To do this, special format strings are added as part of a text overlay. Simply add **#r** (average frame rate in fps) and/or **#b** (average bandwidth in kbps) to the overlay.

For detailed instructions, please see the online help for **Video & Image > Overlay Settings**, and the help for **File Naming & Date/Time Formats**.

Overlay Settings

Include overlay image at the coordinates:

Include date Include time

Include text:

Important!

The figures displayed here are the values as delivered by the camera. If other restrictions are currently in force, (e.g. bandwidth limitation) these values might not correspond to those actually received by the client.

For Motion JPEG, these values are accurate as long as no frame rate limit has been specified.

Frame rates – Motion JPEG and MPEG-4

The following table show typical frame rates in frames/second (fps) for Motion JPEG and MPEG-4 video streams from the AXIS 210A/211A.

Note that these values are guidelines only - actual values may vary.

Motion JPEG settings:

- Viewing in AMC
- Compression level = 30%

MPEG-4 settings:

- Viewing in AMC
- Compression level = 30%
- Video Object Type = Advanced Simple
- GOV length = 8
- GOV structure = IP*

	Frame rates	
	Motion JPEG	MPEG-4
640x480	30	25
480x360	30	30
320x240	30	30
160x120	30	30

Note: Setting the GOV structure to use "I-frames only" will increase the frame rate at the expense of the bit rate.

* The GOV structure can take two different forms; I and IP. The I-structure sends complete images (I-images) whereas the IP-structure mostly sends the differences compared with the previous image (P-images) and only a few I-images. The IP-structure requires much less bandwidth than the I-structure.

Bandwidth

As there are many factors that affect bandwidth, it is very difficult to predict the required amounts. The settings that affect bandwidth are:

- the image resolution
- the image compression
- the frame rate
- the MPEG-4 object type
- the MPEG-4 GOV structure
- the maximum exposure time.

There are also factors in the monitored scene that affect the bandwidth. These are:

- the amount of motion
- the image's complexity
- the lighting conditions.

For MPEG-4, if there is only limited bandwidth available, and if this is more important than the image quality, using a constant bit rate (CBR) is recommended. Use a variable bit rate (VBR) if the image quality needs to be maintained at a higher level. With multiple viewers, and If supported on the network, consider using MPEG-4 multicasting, as the bandwidth consumption is much lower.

Troubleshooting

Checking the Firmware

One of your first actions when troubleshooting a problem should be to check the firmware version. The latest version may contain a correction that fixes your particular problem. The current firmware version in your camera can be seen on the page **Setup > Basic Configuration**.

Upgrading the Firmware

Firmware is software that determines the functionality of the camera. When you upgrade the firmware with a file from the Axis Web site, your camera receives the latest available functionality. Always read the upgrade instructions and release notes available with each new release, before updating the firmware.

Note: Preconfigured and customized settings are saved when the firmware is upgraded (providing the features are available in the new firmware) although this is not guaranteed by Axis Communications. Always read the instructions and release notes available with each new release, before upgrading the firmware.

1. Save the firmware file to your computer. The latest version of the firmware is available free of charge from the Axis Web site at www.axis.com/techsup
2. Go to **Setup > System Options > Maintenance** in the camera's web pages.
3. In the **Upgrade Server** section, browse to the desired firmware file on your computer. Click **Upgrade**.

Upgrade Server

Upgrade the AXIS 211A Network Camera with the latest firmware.

Specify the firmware to upgrade to: **Browse...** and click **Upgrade**

Note: Do not disconnect power to the unit during the upgrade. The unit restarts automatically after the upgrade has completed. (1-10 minutes.)

Notes: After starting the upgrade process, always wait at least 5-10 minutes before restarting the camera, even if you suspect the upgrade has failed.

Your dealer reserves the right to charge for any repair attributable to faulty upgrading by the user.

Emergency Recovery Procedure

If power or the network connection to the camera is lost during the upgrade, the process fails and the unit becomes unresponsive. A flashing red Status LED indicates a failed upgrade. To recover the unit, follow the steps below. The serial number is found on the label attached to the bottom of the camera.

1. **Unix/Linux** - From the command line, type the following:

```
arp -s <IP address of camera> <Serial number> temp  
ping -s 408 <IP address of camera>
```

Windows - From a command/DOS prompt, type the following:

```
arp -s <IP address of camera> <Serial number>  
ping -l 408 -t <IP address of camera>
```

2. If the unit does not reply within a few seconds, restart it and wait for a reply. Press CTRL+C to stop Ping.
3. Open a browser and type in the camera's IP address. In the page that appears, use the **Browse** button to select the upgrade file to use, e.g. axis210.bin or axis211.bin. Then click the **Load** button to restart the upgrade process.
4. After the upgrade has completed (1-10 minutes), the unit automatically restarts and shows a steady green on the Power and Status LEDs and flashing green or amber on the Network LED.
5. Referring to the installation guide, reinstall the camera.

If the emergency recovery procedure does not get the camera up and running again, please contact Axis support at www.axis.com/techsup/

Axis Support

If you contact Axis support, please help us to help you solve your problems, by providing the server report, the log file and a brief description of the problem.

Server Report - go to **Setup > System Options > Support Overview**. The server report contains important information about the server and its software, as well as a list of the current parameters.

The **Log file** is available from **Setup > System Options > Logs & Reports**. The Log file records events in the unit since the last system restart and can be a useful diagnostic tool when troubleshooting.

Symptoms, Possible Causes and Remedial Actions

Problems setting the IP address

When using ARP/Ping.	Try the installation again. The IP address must be set within two minutes after power has been applied to the camera. Ensure the Ping length is set to 408. See the Installation Guide.
The camera is located on a different subnet.	If the IP address intended for the camera and the IP address of your computer are located on different subnets, you will not be able to set the IP address. Contact your network administrator to obtain an appropriate IP address.
The IP address is being used by another device	<p>Disconnect the camera from the network. Run the Ping command. (In a Command/DOS window, type ping and the IP address of the unit).</p> <p>If you receive: Reply from <IP address>: bytes = 32; time = 10 ms..... - this means that the IP address may already be in use by another device on your network. You must obtain a new IP address and reinstall the unit.</p> <p>If you see: Request timed out - this means that the IP address is available for use with your camera. In this case, check all cabling and reinstall the unit.</p>
Possible IP address conflict with another device on the same subnet.	The static IP address in the camera is used before the DHCP server sets a dynamic address. This means that if the same default static IP address is also used by another device, there may be problems accessing the camera. To avoid this, set the static IP address to 0.0.0.0.

The camera cannot be accessed from a browser

The IP address has been changed by DHCP.	<ol style="list-style-type: none"> 1) Move the camera to an isolated network or to one with no DHCP or BOOTP server. Set the IP address again, using the AXIS IP Utility (see the Installation Guide) or the ARP/Ping commands. 2) Access the unit and disable DHCP in the TCP/IP settings. Return the unit to the main network. The unit now has a fixed IP address that will not change. 3) As an alternative to 2), if dynamic IP address via DHCP or BOOTP is required, select the required service and then configure IP address change notification from the network settings. Return the unit to the main network. The unit now has a dynamic IP address, but will notify you if the address changes.
Proxy server.	If using a proxy server, try disabling the proxy setting in your browser.
Other networking problems.	Test the network cable and connectors by connecting it to another network device, then Ping that device from your workstation. See the instructions above.
Cannot log in.	When HTTPS is enabled, ensure that the correct protocol (HTTP or HTTPS) is used when attempting to log in. You may need to manually type in http or https in the browser's address bar.
Incorrect host name.	Check that the host name and DNS server settings are correct. See the basic and advanced TCP/IP settings.

Cannot send notifications, uploads, alarms, etc, to a destination outside the local network

Firewall protection.	The camera can be configured to use a SOCKS server to reach networks on the other side of a firewall/proxy server.
----------------------	--

Camera is accessible locally, but not externally

Firewall protection.	Check the Internet firewall with your system administrator.
Default routers required.	Check if you need to configure the default router settings.

Poor or intermittent network connection.

Network switch.	<p>If using a network switch, check that the port on that device uses the same setting for the network connection type (speed/duplex) as set in the advanced TCP/IP settings.</p> <p>The Auto-Negotiate setting is recommended.</p>
-----------------	---

Video/Image problems – general

No images in browser (<i>Internet Explorer for Windows only</i>)	To enable the updating of video images in Microsoft Internet Explorer for Windows, set your browser to allow ActiveX controls. Also, make sure that AXIS Media Control (AMC) component is installed on your workstation.
Installation of additional ActiveX component restricted or prohibited.	Configure your camera to use a Java applet for updating the video images under Live View Config > Layout > Default Viewer for Internet Explorer. See the online help for more information.
Image too dark or too light.	Check the video image settings. See the online help on Video and Image Settings.
Missing images in uploads.	This can occur when trying to use a larger image buffer than is actually available. Try lowering the frame rate or the upload period.
Slow image update.	Configuring, e.g. pre-buffers, motion detection, high-resolution images, and high frame rates, will reduce the performance of the camera.
Poor performance.	Poor performance may be caused by e.g. heavy network traffic, multiple users accessing the unit, low performance clients, use of features such as Motion Detection, Event handling, Image rotation other than 180 degrees.
Image gradually gets darker or lighter.	When using the camera in locations lit by fluorescent lighting, check in the advanced image settings that the Exposure control is set to Flicker-free .
Image loses focus often.	Disable the DC-Iris lens (AXIS 211A only) in the settings for Video & Image > Advanced . Focus the camera following the instructions on page 11, and then enable the DC-Iris lens.
Images only shown in black & white.	Check the color level setting.
Blurred images.	Refocus the camera. Check in the Video & Image > Advanced - Camera Settings that DC-Iris (AXIS 211A only) is set to Enabled. If the images are still blurred adjust the metal ring until the image is sharp.
Rolling dark bands or flickering in image.	Try adjusting the Flicker-free exposure setting under advanced image settings. Note that the 'Hold Current'/Manual setting may cause unwanted effects.

Video/image problems – MPEG-4

Lower frame rate than expected.	<p>Check with the administrator that there is enough bandwidth available. Check also the settings for bit rate control, in the Video & Image > Advanced > MPEG-4 settings. Using an inappropriate video object type can also affect the frame rate. See the online help for more information.</p> <p>Check in the AMC control panel applet (MPEG-4 tab) that video processing is not set to Decode only I frames.</p> <p>Lower the image resolution.</p> <p>Reduce the number of applications running on the client computer.</p>
No MPEG-4 displayed in the client.	<p>Check that the correct network interface is selected in the AMC control panel applet (network tab).</p> <p>Check that the relevant MPEG-4 connection methods are enabled in the AMC control panel applet (network tab).</p> <p>In the AMC control applet, select the MPEG-4 tab and click the button Set to default MPEG-4 decoder.</p>
No multicast MPEG-4 displayed in the client.	Check with your network administrator that the multicast addresses used by the AXIS 210A/211A are valid for your network.
Multicast MPEG-4 only accessible by local clients.	Check if your router supports multicasting, or if the router settings between the client and the server need to be configured. The TTL (Time To Live) value may need to be increased.

Poor rendering of MPEG-4 images.	Color depth set incorrectly on clients. Set to 16-bit or 32-bit color. If text overlays are blurred, or if there are other rendering problems, you may need to enable Advanced Video Rendering. This is done on the MPEG-4 tab in the AMC control panel applet. Ensure that your graphics card is using the latest device driver. The latest drivers can usually be downloaded from the manufacturer's web site. If images are degrading, try decreasing the GOV length, see " <i>Advanced Settings</i> " on page 22.
Color saturation is different in MPEG-4 and Motion JPEG.	Modify the settings for your graphics adapter. Please see the adapter's documentation for more information.
The test image does not display as expected.	
Image settings.	Not all settings have an effect on the test image. For more information, see the help on Image Settings.
The Power indicator is not constantly lit	
Faulty power supply.	Check that you are using an AXIS PS-K power supply.
The Status and Network indicator LEDs are flashing red rapidly	
Hardware failure.	Contact your Axis dealer.
The Status indicator LED is flashing red and the camera is inaccessible	
A firmware upgrade has been interrupted or the firmware has otherwise been damaged.	See the <i>Emergency Recovery Procedure</i> above.
Poor quality snapshot images	
Screen incorrectly configured on your workstation.	In Display Properties, configure your screen to show at least 65000 colors, i.e. at least 16-bit. Using only 16 or 256 colors will produce dithering artifacts in the image.
Browser freezes	
Netscape 7.x or Mozilla 1.4 (or later) can sometimes freeze on a slow computer.	Lower the image resolution.
Problems uploading files	
Limited space.	There is only limited space available for the upload of your own files. Try deleting one or more existing files, to free up space.
Missing images in uploads.	This can occur when trying to use a larger image buffer than is actually available. Try lowering the frame rate or the upload period.
Overlay is not displayed	
Incorrect size or location of overlay.	The overlay may have been positioned incorrectly. Refer to the online help for information on the limitations when using image overlays and privacy masks.
Motion Detection triggers unexpectedly	
Changes in luminance.	Motion detection is based upon changes in luminance in the image. This means that if there are sudden changes in the lighting, motion detection may be mistakenly triggered. Lower the sensitivity setting to avoid problems with luminance.
No audio	
Incorrect setup.	Check that the sound card in the PC and the connections to the speaker and microphone are working. Ensure that the mute button is not pressed and the volume settings are correct. Ensure that full-duplex is selected if you want to have two way audio communication.
Post Content Length in proxy server.	The Post Content Length set in the proxy server is too low. Set the value of the Post Content Length in your proxy server to 1MB or more. You may need to contact your system administrator to do this.

Full duplex not supported.	Sound card does not support full-duplex. For information on how to check if your sound card supports full-duplex, please visit http://support.microsoft.com
Firewall or router settings.	The AXIS 210A/211A works locally, but not externally. Check the Internet firewall settings with your system administrator or reconfigure the default router settings.
DC power not enabled for microphone.	If the microphone has a built-in amplifier then the DC power must be enabled on the Audio Settings page.

Audio volume too low/high

Volume settings incorrect.	The volume of the microphone or speaker connected to the AXIS 210A/211A is either too high or too low. Change the volume for the speaker or microphone in the Live View page.
Input and output gain set incorrectly.	Change the input gain for the microphone and the output gain for the speaker to adjust the audio levels on the Audio Settings page.

Poor audio quality

Too many users.	Too many users/clients connecting to the AXIS 210A/211A may affect the sound quality adversely. Try limiting the number of clients allowed to connect on the Audio Settings page.
User too close to microphone.	Enable the speech filter in Audio > Advanced Settings .
Feedback from speaker.	Enable the echo cancellation filter in Audio > Advanced Settings .
Background noise.	Adjust the noise cancellation threshold and attenuation to reduce background noise levels in Audio > Advanced Settings .
CPU overloaded.	Reduce the number of listeners and viewers and decrease the image resolution and compression.

For additional assistance, please contact your reseller or see the support pages on the Axis Website at www.axis.com/techsup

Glossary of Terms

Active Speaker - a speaker with a built-in power amplifier.

ActiveX - A control (or set of rules) used by a browser. ActiveX controls are often downloaded and installed automatically as required.

ADPCM - Adaptive Differential Pulse Code Modulation. Predicts the analog signal digitally and the difference is coded.

AMC - AXIS Media Control. The control required for viewing video images in Internet Explorer for Windows. Installs automatically on first use.

API - Application Programming Interface. The Axis API can be used for integrating Axis products into other applications.

ARP - Address Resolution Protocol. A protocol for assigning an IP address to a physical device address that is recognized in the local network. The ARP command can be used to set the IP-address for your product.

ARTPEC - Axis Real Time Picture Encoder - used for video image compression.

CCD - Charge Coupled Device. CCD is one of the two main types of image sensors used in digital cameras. When a picture is taken, the CCD is struck by light coming through the camera's lens. Each of the thousands or millions of tiny pixels that make up the CCD convert this light into electrons.

CGI - Common Gateway Interface. A set of rules (or a program) that allows a Web Server to communicate with other programs.

Client/Server - Describes the network relationship between two computer programs in which one, the client, makes a service request from another - the server.

dB (Decibels) - A unit to measure sound level changes. A 3dB change is the smallest level change we can hear. A 3dB change is actually twice or half the audio power level. A gain of 0dB leaves the signal level unchanged.

DC-Iris - This special type of iris is electrically controlled by the Axis camera, to automatically regulate the amount of light allowed to enter.

DNS - The Domain Name System (DNS) locates and translates Internet domain names into IP (Internet Protocol) addresses.

Ethernet - A widely used networking standard.

ETRAX - Axis' own microprocessor.

Firewall - A virtual barrier between a LAN (Local Area Network) and other networks, e.g. the Internet.

FTP - File Transfer Protocol. Used for the simple transfer of files to and from an FTP-server.

Full duplex - Transmission of data, e.g. audio, in two directions simultaneously.

G.711 - G.711 is the international standard for encoding telephone audio on 64 kBit/s channel. It is a pulse code modulation (PCM) scheme operating at 8 kHz sample rate.

G.726 - Frequently used speech-compression algorithm in telecommunications due to its high perceived speech quality and low resource requirements.

Half duplex - A half duplex link can communicate in only one direction, at a time. Two way communication is possible, but not simultaneously. Walkie-talkies and CB radios mimic this behavior in that you cannot hear the other person if you are talking.

HTML - Hypertext Mark-up Language. Used widely for authoring documents viewed in web browsers.

HTTP - Hypertext Transfer Protocol. The set of rules for exchanging files (text, images, sound, video, and other files) on the World Wide Web.

HTTPS - Hypertext Transfer Protocol over Secure Socket Layer. A web protocol that provides encryption for page requests from users and for the pages returned by the web server.

Intranet - A private network limited to an organization or corporation. Usually closed to external traffic.

IP - Internet-Protocol. See TCP/IP.

IP address - A unique number used by a network device, to allow it to be identified and found on the network. The 32-bit IP address is made up of four groups (or quads) of decimal digits separated by periods. An example of an IP address is: 192.168.0.1

ISMA - Internet Streaming Media Alliance

JPEG - A standard image format, used widely for photographs. Also known as JPG.

LAN - A local area network (LAN) is a group of computers and associated devices that typically share common resources within a limited geographical area.

Linux - A popular operating system, which is "open source" and practically free of charge.

Lux - A standard unit for the measurement of light, where 1 Lux equals the light emitted from a single candle at a distance of one meter.

Mbit/s - Megabits per second. A unit for measuring speeds in networks. A LAN might run at 10 or 100 Mbit/s.

MPEG-4 - A standard video format, used for low bandwidth video streams.

Multicast - The same information is sent only once and only to the intended recipients.

NTSC - National Television Standards Committee. NTSC is the standard format used for televisions in most of North and Central America, and Japan.

NWAY - A network protocol that automatically negotiates the highest possible common transmission speed between two devices.

PAL - Phase Altering Line. PAL is the standard format used for televisions in most of the world (other than the US, Canada, and Japan).

PCM - Pulse Code Modulation. Analog signal converted directly to a digital.

Ping - A small utility used for sending data packets to network resources to check that they are working and that the network is intact.

Pre/post alarm image - The images from immediately before and after an alarm.

Protocol - A special set of rules governing how two entities communicate. Protocols are found at many levels of communication, and there are hardware protocols and software protocols.

Router - A device that determines the next network point to which a packet should be forwarded on its way to its final destination. A router is often included as part of a network switch (see below).

RTP- Real-Time Transfer Protocol. A transfer protocol designed for delivery of live contents, e.g. MPEG-4.

Simplex - In simplex operation, a network cable or communications channel can only send information in one direction.

SMTP - A common e-mail protocol.

SNMP - Simple Network Management Protocol. An application layer protocol that facilitates the exchange of management information between network devices. It is part of the Transmission Control Protocol/Internet Protocol (TCP/IP) protocol suite.

Subnet Mask - An IP address consists of two components: the network address and the host address. "Subnetting" enables a network administrator to further divide the host part of the address into two or more subnets. The subnet mask identifies the subnet to which an IP address belongs.

Switch - Whilst a simple hub transmits all data to all devices connected to it, a switch only transmits the data to the device it is specifically intended for.

TCP/IP - Transmission Control Protocol/Internet Protocol. A suite of network protocols that determine how data is transmitted. TCP/IP is used on many networks, including the Internet. TCP keeps track of the individual packets of information and IP contains the rules for how the packets are actually sent and received.

URL - Uniform Resource Locator. An "address" on the network.

Varifocal - A varifocal lens provides a wide range of focal lengths, as opposed to a lens with a fixed focal length, which only provides one.

WAN - Wide-Area-Network. Similar to a LAN, but on a larger geographical scale.

Web server - A program on a computer (server) providing the resources (e.g. web pages) requested by the user (client).

Index

Symbols

(PoE) Power over Ethernet 6

A

Accessing the video stream 16

Action 36

Action Buttons 12, 32

Administrator 19

Advanced Simple profile 14

Alarm 39, 55

AMC Viewer Toolbar 13

Audio input 27

Audio mode 26

Audio output 28

Auxiliary Power 55

AXIS 16

AXIS Media Control 16, 27

B

Backup 52

Bandwidth 14, 62

Bit rate 14

Buffer Size 38

Buffers 38

C

CGI links 33

Control Button 8, 53

Custom settings 30

D

Date & Time 45

DC Power 55

DC-Iris 6

DNS Configuration 46

DNS Server 46, 47

Domain Name 47

E

Emergency Recovery 64

Event Servers 36

Event Types 37

Events 36

External Video 33

External Video Source 12

F

Frame rate 21

FTP Server 36

Full duplex 6, 26, 27

H

Half duplex 6, 26, 27

Host Name 47

HTML Examples 33

HTTP 47

HTTP API 33

HTTP Server 36

HTTP-API 17

HTTPS 6, 42, 47

I

I/O Ports 51

I/O Terminal Connector 8, 55

Input 55

IP Address Filtering 41

L

Live View 12, 19

Live View Config 30

Logs & Reports 52

M

Motion Detection 39

Motion JPEG 14, 17

MPEG-4 5, 14, 17

MPEG-4 protocols 15

Multicasting 15

N

NAT Traversal 47

NAT traversal 48

Network Connector 8

Network Settings 46
NTP Configuration 47
NTP Server 45

O

Other MPEG-4 clients 16
Output 55
Output Buttons 32
Output buttons 12
Own home page 32
Own web files 30

P

Pinout - I/O connectors 55
PoE 8
Port Status 40
Ports & Devices 51
Post-trigger Buffer 38
Power Connector 8
Pre-trigger Buffer 38
Pulse 12
Push to talk 27

R

Recovery 64
Referrals 42
Restore 51, 52
RTP 15
RTSP 15

S

Scheduled Event 36, 38
Security 41
Sequence Mode 12, 34
Sequence mode 12

Serial Number 8
Server Time 45
Services 46
Simple profile 14
Simplex 6, 26
SMTP 50
Snapshot button 12
SNMP 6, 50
SOCKS 49
Streaming MPEG-4 15
Support 52
Synchronization 17
System Options 41

T

TCP Server 36
TCP/IP Settings 46
Text overlay 21
Time Mode 45
Triggered Event 36
Troubleshooting 64
Two-way audio 6

U

UDP 15
Unicasting 15
Upgrade Server 52
Upload overlay/mask 22
Uploading web files 32
User Defined Links 32
Users 41

V

Variable bit rate 14

