

USER'S MANUAL

AXIS 212 PTZ Network Camera

AXIS 212 PTZ-V Network Camera

Notices

This manual is intended for administrators and users of the AXIS 212 PTZ/-V Network Camera, and is applicable for firmware release 4.49 and later. It includes instructions for using and managing the camera on your network. Previous experience of networking will be of use when using this product. Some knowledge of UNIX or Linux-based systems may also be beneficial, for developing shell scripts and applications. Later versions of this document will be posted to the Axis Website, as required. See also the product's online help, available via the Web-based interface.

Liability

Every care has been taken in the preparation of this manual. Please inform your local Axis office of any inaccuracies or omissions. Axis Communications AB cannot be held responsible for any technical or typographical errors and reserves the right to make changes to the product and manuals without prior notice. Axis Communications AB makes no warranty of any kind with regard to the material contained within this document, including, but not limited to, the implied warranties of merchantability and fitness for a particular purpose. Axis Communications AB shall not be liable nor responsible for incidental or consequential damages in connection with the furnishing, performance or use of this material.

Intellectual Property Rights

Axis AB has intellectual property rights relating to technology embodied in the product described in this document. In particular, and without limitation, these intellectual property rights may include one or more of the patents listed at <http://www.axis.com/patent.htm> and one or more additional patents or pending patent applications in the US and other countries.

This product contains licensed third-party software. See the menu item "About" in the product's user interface for more information.

This product contains source code copyright Apple Computer, Inc., under the terms of Apple Public Source License 2.0 (see <http://www.opensource.apple.com/apsl/>). The source code is available from: <http://developer.apple.com/darwin/projects/bonjour/>

Equipment Modifications

This equipment must be installed and used in strict accordance with the instructions given in the user documentation. This equipment contains no user-serviceable components. Unauthorized equipment changes or modifications will invalidate all applicable regulatory certifications and approvals.

Trademark Acknowledgments

Apple, Boa, Bonjour, Ethernet, Internet Explorer, Linux, Microsoft, Mozilla, Netscape Navigator, OS/2, Real, QuickTime, UNIX, Windows, WWW are registered trademarks of the respective holders. Java and all Java-based trademarks and logos are trademarks or registered trademarks of Sun Microsystems, Inc. in the United States and other countries. Axis Communications AB is independent of Sun Microsystems Inc. UPnP™ is a certification mark of the UPnP™ Implementers Corporation.

Support

Should you require any technical assistance, please contact your Axis reseller. If your questions cannot be answered immediately, your reseller will forward your queries through the appropriate channels to ensure a rapid response. If you are connected to the Internet, you can:

- download user documentation and firmware updates
- find answers to resolved problems in the FAQ database. Search by product, category, or phrases
- report problems to Axis support by logging in to your private support area
- visit Axis Support at www.axis.com/techsup

Contents

Product Overview	5
Key Features	5
Hardware Overview	6
I/O terminal connector – Pinout	7
LED indicators	7
Accessing the Camera	8
Access from a browser	8
Setting the Root Password	8
AXIS Media Control	9
Accessing the camera from the Internet	9
Adjust focus	9
The Live View Page	10
Pan/Tilt/Zoom controls	11
The control panel	11
AMC audio controls	11
Video Streams	12
How to stream MPEG-4	12
Other MPEG-4 clients	13
Stream Types	13
Alternative methods of accessing the video stream	14
Configuration	15
Accessing the configuration menus	15
Video and Image settings	16
Image	16
Overlay Image	17
Advanced	17
Audio Settings	19
Live View Config	21
Layout	21
HTML Examples	25
External Video	25
Sequence Mode	25
PTZ Configuration	26
Preset Positions	26
Guard tour	26
Advanced – Ctrl Panel	26
Event Configuration	27
Event Servers	27
Event Types	27
Motion Detection	29
Port Status	30
System Options	31
Security	31
Date & Time	33
Network	33
Ports & Devices	37
LED	37
Maintenance	38
Support	38
Advanced	39
Resetting to the Factory Default Settings	39
The I/O Terminal Connector	40
Pinout and Interface	40
Troubleshooting	42
Checking the Firmware	42
Upgrading the Firmware	42
Emergency Recovery Procedure	43
Axis Support	43
Symptoms, Possible Causes and Remedial Actions	44

Technical Specifications	47
Optimizing your system	50
Bandwidth	50
Glossary of Terms	51
Index	56

Product Overview

AXIS 212 PTZ/-V Network Camera is ideal for surveillance and remote monitoring, offering overview images and instant one-click Pan/Tilt/Zoom control. It combines a 3-Megapixel sensor with a wide-angle lens, providing VGA resolution. With no moving parts, this camera offers guard tour functionality without wear and tear.

The built-in Power over Ethernet support reduces cabling and installation costs, as well as consolidating power for higher reliability. Simultaneous Motion JPEG and MPEG-4 video streams, a comprehensive set of network security features and two-way audio support increase the surveillance and monitoring options.



For indoor use only

Key Features

- Instant one-click Pan, Tilt and Zoom
- PTZ with no moving parts - no wear and tear
- Simultaneous MPEG-4 and Motion JPEG for optimized quality and bandwidth
- Power over Ethernet for reduced cabling and consolidated power
- Two-way audio, including built-in microphone and detection alarm
- 140° pan and 105° tilt
- Pan & Tilt speed 400°/1 sec.
- 3x instant zoom
- Tamper proof mounting

Hardware Overview

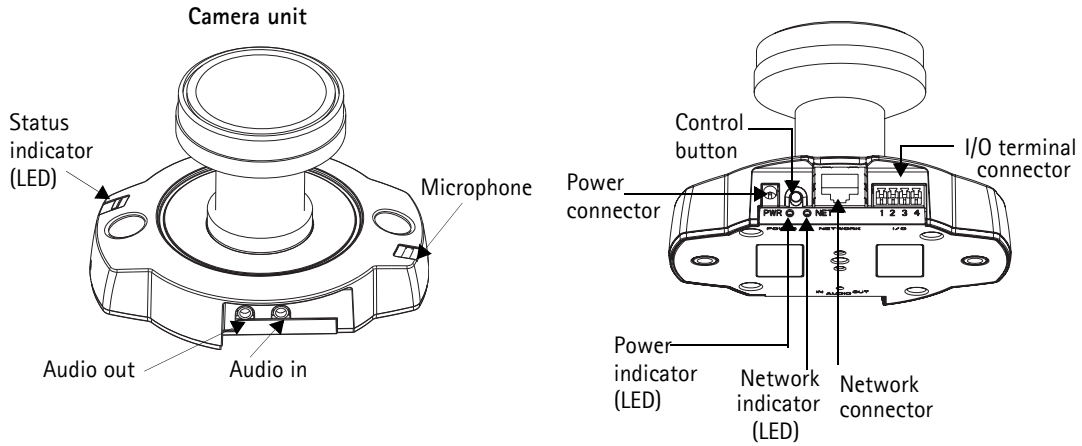

Dome casing for AXIS 212 PTZ

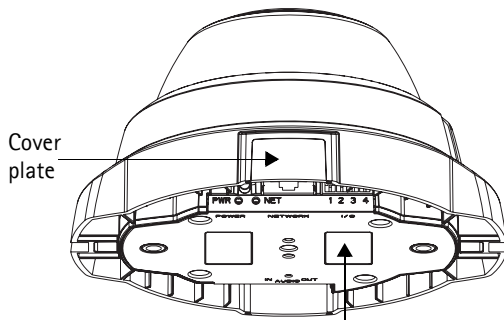

Dome casing for AXIS 212 PTZ-V

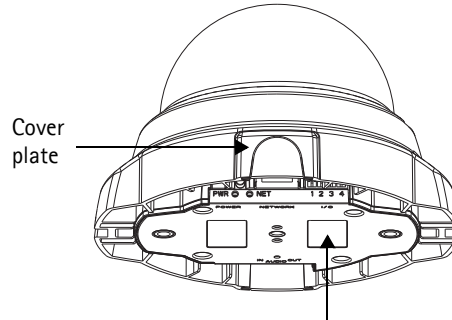

Serial number (S/N) - The serial number is required during the installation. Please retain this for future reference.

Power connector - For connection of the PS-H power adapter (included).

I/O terminal connector - The I/O terminal connector provides the physical interface to one transistor output, one digital input and an auxiliary connection point for DC power. For more information, see *The I/O Terminal Connector*, on page 40.

Network connector - The camera connects to the network via a standard network connector. Supporting NWAY, the camera detects the speed of the local network segment (10BaseT/100BaseTX Ethernet). Supporting PoE (Power over Ethernet), the camera can be powered directly from the network cabling.

Audio out - Audio output (line level), which can be connected to a public address (PA) system or an active speaker with a built-in amplifier. A pair of headphones can also be attached. A stereo connector must be used for the audio out.

Audio in - One 3.5mm input for a mono microphone, or for line-in mono signal (left channel is used from a stereo signal).

Microphone - Built-in microphone. To prevent unauthorized listening, the internal microphone can be disabled by inserting a plug in the 'Audio in' connector.

Serial number label - The serial number may be required during installation.

Control button - Press this button to install the camera using the AXIS Internet Dynamic DNS Service, or to restore the factory default settings, as described in *Resetting to the Factory Default Settings*, on page 39.

I/O terminal connector – Pinout

See *The I/O Terminal Connector*, on page 40.

LED indicators

LED	Color	Description
Network	Green	Steady for connection to 100 Mbit/s network. Flashes for network activity.
	Amber	Steady for connection to 10 Mbit/s network. Flashes for network activity.
	Unlit	No connection.
Status	Green	Shows steady green for normal operation. Note: The Status LED can be configured to be unlit during normal operation, or to flash only when the camera is accessed. See the online help files for more information. Go to Setup > System Options > LED settings
	Amber	Steady during startup, reset to factory default or when restoring settings.
	Red	Slow flash for failed upgrade.
Power	Green	Normal operation.
	Amber	Flashes green/amber during firmware upgrade.

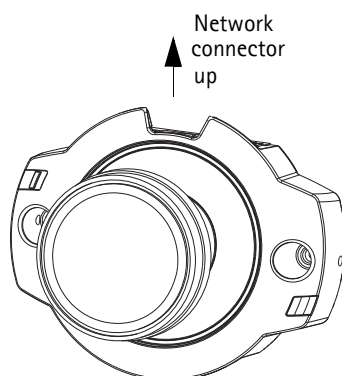

Note:

To achieve correct image orientation, AXIS 212 PTZ/-V must be mounted with the network connector facing upwards.

Accessing the Camera

To install the camera on the network, please see the supplied installation guide. The camera can be used with most standard operating systems and browsers. The recommended browser is Microsoft Internet Explorer with Windows, Safari with Mac OS and Firefox with other operating systems.

Notes:

- To view streaming video in Microsoft Internet Explorer, set your browser to allow ActiveX controls and allow the AXIS Media Control (AMC) to be installed on your workstation.
- QuickTime™ and Real Player™ are also supported for viewing streaming MPEG-4 video and audio.
- If your workstation restricts the use of additional software components, the camera can be configured to use a Java applet for viewing Motion JPEG.
- The AXIS 212 PTZ/-V includes one (1) decoder license for viewing MPEG-4 video streams. This is automatically installed with AMC. The administrator can disable the installation of the MPEG-4 decoder, to prevent unlicensed copies being installed.

Access from a browser

1. Start a browser (for example, Internet Explorer, Firefox).
2. Enter the IP address or host name of the camera in the **Location/Address** field of your browser.

To access the camera from a Macintosh computer (Mac OSX), simply click on the Bonjour tab and select the AXIS 212 PTZ from the drop-down list.

3. If this is the first time the camera is accessed, see *Setting the Root Password*, on page 8. Otherwise enter your user name and password, as set by the administrator.
4. The camera's Live View page now appears in your browser.



Note:

The layout of the Live View page may have been customized to specific requirements. Consequently, some of the examples and functions featured here may differ from those displayed on your own Live View page.

Setting the Root Password

1. When accessing the camera for the first time, the **Configure Root Password** dialog appears.



2. Enter a password and re-enter, to confirm the spelling. Click **OK**. If the password is lost, the camera must be reset to the factory default settings. See page 39.
3. If required, click **Yes** to install the AXIS Media Control (AMC). You will need administrator rights on the computer to do this.

Note:

The default administrator user name **root** is permanent and cannot be deleted.



AXIS Media Control

The AXIS Media Control (AMC) is installed automatically the first time the camera is accessed from Microsoft Internet Explorer. The AMC control panel can be opened by right-clicking on the video image in the Live View web page. The AMC control panel can be used to configure various video and audio settings. Please see the readme file included in the tool for more information. The AMC manual is available from the **Network Video** link in axis.com/techsup

Accessing the camera from the Internet

Once installed, the camera is accessible on your local network (LAN). To access the camera from the Internet you must configure your broadband router to allow incoming data traffic to the camera. One way to do this is to enable the NAT-traversal feature, which will attempt to automatically configure the router to allow access to the camera. This is enabled from **Setup > System Options > Network > TCP/IP Advanced**.

For more information, please see *NAT traversal (port mapping)*, on page 35. See also the AXIS Internet Dynamic DNS Service at www.axiscam.net or, for Technical notes on this and other topics, visit the Axis Support Web at www.axis.com/techsup

Adjust focus

If the image is out of focus, the camera's preset focus position needs to be adjusted. Follow these instructions to focus the camera:

1. Remove the dome casing.
2. Open the Live View page in a web browser.
3. Set the camera view to maximum zoom, i.e. click on a suitable detail in the image to zoom in.
4. Rotate the metal focus adjustment ring (see illustration) to set the focus.

Important!

Older camera models have a fixing screw that must be loosened before rotating the focus adjustment ring. The screw is located close to the audio in/audio out connectors. Gently tighten the screw when satisfied with the image.

5. When satisfied with the image, mount the dome casing. For instructions please refer to the Installation Guide supplied with the camera.

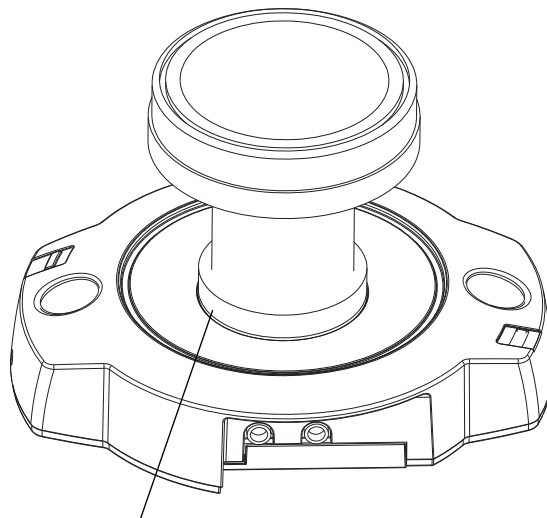

Focus adjustment ring

The Live View Page

Depending on whether or not the Live View page has been customized, the buttons described below may or may not be visible.

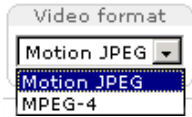

The **Video Format** drop-down list allows the video format on the Live View page to be temporarily changed.

The **Output** buttons control the output directly from the Live View page. These buttons are configured under **Setup > Live View Config > Layout**.



Active/Inactive – click these buttons to manually start and stop a connected device, for example, switch a light on/off.



Pulse – click this button to activate the output for a defined period of time, for example, to switch on a light for 20 seconds.



The **Action** buttons can trigger an event directly from the Live View page. These are configured under **Setup > Live View Config > Layout**.



The **Snapshot** button saves a snapshot of the video image currently being displayed. Right-click on the video image to save it in JPEG format on your computer. This button is primarily intended for use when the AMC viewer toolbar is not available.

The **AMC (AXIS Media Control) viewer toolbar** is only available for **Microsoft Internet Explorer**. It provides the following buttons:



The **Play/Stop** button starts and stops the live video stream.



The **Snapshot** button saves a snapshot of the video image currently being displayed. The Snapshot function and the target directory for saving snapshots can be configured from the AMC Control Applet in the Windows Control Panel (Internet Explorer only).



The **record** button is used to record the current (MPEG-4) video stream. The location where the image file is saved can be specified using the AMC control panel. To enable recording, Select **Live View Config > Viewer Settings > Enable recording button**.



Click the **View Full Screen** button to make the video image fill the entire screen area. No other windows will be visible. Press **Esc (Escape)** on the computer keyboard to exit full screen.



These buttons change the navigation mode. Selecting **Center** will move the camera view to center on the position that was clicked. **Joystick** mode will move the camera in the direction indicated by a mouse click, relative to the center of the image. The further from the center the image is clicked, the greater the movement. These modes can also be selected by right-clicking in the image.

Note:

The snapshot function in MPEG-4 full screen mode will return the image view to the default live view page. Click the **View Full Screen** button to return to Full Screen Mode.

Pan/Tilt/Zoom controls

AXIS 212 PTZ/-V can be controlled by clicking in the image, or by clicking on the **Pan/Tilt/Zoom** bars on the Live View page. These are enabled/disabled for specified users by the administrator under **System Options > Security > Users > User List**.

Zoom out to overview image will set the camera to the minimum zoom position. Note that when in this position, the camera cannot pan or tilt.



The control panel

Click the **Ctrl panel** button to display the control panel. The panel provides buttons for switching between **PanTilt** and **ZoomFunc** when in **Center** mode. This controls whether the camera should pan/tilt to the position in the image that was clicked, or whether it should zoom directly in on that point.

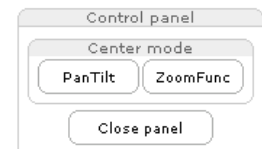

The Control panel can also show your own shortcut buttons, which are configured from **Setup > PTZ Configuration > Advanced**.

Note:

The scroll wheel on the mouse can also be used to control the zoom.

AMC audio controls

AXIS 212 PTZ/-V can transmit audio to clients using either the built-in microphone or a connected external microphone and can play audio received from clients via a connected speaker. There are audio controls for controlling the microphone and the client computer's speaker output. These controls are only available when audio is enabled, see *AXIS Media Control*, on page 9 and *Audio Settings*, on page 19. See also the *AMC User's Manual* for more information at: <http://www.axis.com/techsup/software/amc/>

 Click the **Speaker** and **Microphone** buttons to switch the sound off and on for the speaker and microphone, respectively.



 Use the sliders to control the volume on the speaker and microphone. The volume can be set between 0 and 100.

 When using **Half-duplex** mode, this button toggles between allowing you to speak and listen. The first icon indicates that you can talk and the speaker connected to the camera will play your voice. The second indicates that you will hear audio from the camera.

 **Simplex - Network Camera speaker only** - the speaker connected to AXIS 212 PTZ/-V will play audio transmitted from any web client. This mode requires you to use the push to talk button.

Simplex - Network Camera microphone only - transmits audio from AXIS 212 PTZ/-V to any web clients. This can be used in remote monitoring, web attractions etc., to provide live audio from a monitored situation.

Note:

External microphones and speakers are optional items and are not included with the product.

Video Streams

AXIS 212 PTZ/-V provides several different image and video stream formats. The type to use depends on your requirements and on the properties of your network.

Unicasting is communication between a single sender and a single receiver over a network. This means that the video stream goes independently to each user, and each user gets their own stream.

Multicast is bandwidth-conserving technology that reduces bandwidth usage by simultaneously delivering a single stream of information to multiple network users.

The Live View page in AXIS 212 PTZ/-V provides access to Motion JPEG and MPEG-4 video streams, as well as to single JPEG images. Other applications and clients can also access these video streams/images directly, without going via the Live View page.

How to stream MPEG-4

Deciding on the combination of protocols and methods to use depends on your viewing requirements, and on the properties of your network.

Unicast RTP	This unicast method (RTP over UDP) should be your first consideration for live unicast video, especially when it is important to always have an up-to-date video stream, even if some images are dropped.	Unicasting is used for video streaming, so that there is no video traffic on the network until a client connects and requests the stream. Note that there are a maximum of 20 simultaneous unicast connections.
RTP over RTSP	This unicast method (RTP tunneled over RTSP) is useful as it is relatively simple to configure firewalls to allow RTSP traffic.	
RTP over RTSP over HTTP	This unicast method can be used to traverse firewalls. Firewalls are commonly configured to allow the HTTP protocol, thus allowing RTP to be tunneled.	
Multicast RTP	This method (RTP over UDP) should be used for live multicast video. The video stream is always up-to-date, even if some images are dropped. Multicasting provides the most efficient usage of bandwidth when there are large numbers of clients viewing simultaneously. A multicast broadcast cannot however, pass a network router unless the router is configured to allow this. It is not possible to multicast over the Internet, for example. Note also that all multicast viewers count as one unicast viewer in the maximum total of 10 simultaneous connections.	

AXIS Media Control (AMC)

The recommended method of accessing live video (MPEG-4 and Motion JPEG) from AXIS 212 PTZ/-V is to use AXIS Media Control (AMC) in Microsoft Internet Explorer in Windows.

The AMC control panel can be used to configure various video and audio settings. Please see the readme file included in the tool for more information.

The AMC control panel is automatically installed on first use, after which it can be configured.

Open the AMC Control Panel from:

- Windows Control Panel (from the Start menu)
- Alternatively, right-click the video image and click **Settings** in the menu.

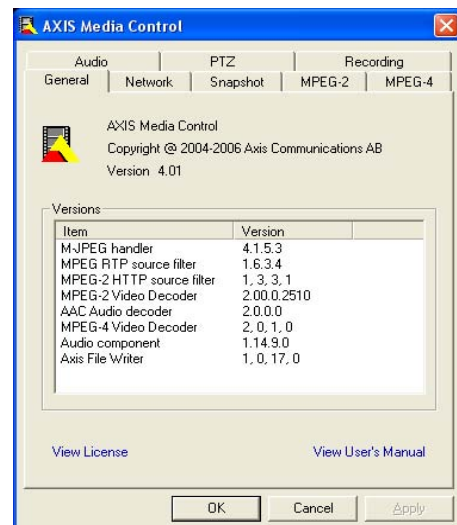

Other MPEG-4 clients

QuickTime™ & Real Player™

To access the video stream from, for example, QuickTime™ or Real Player™ the following paths can be used:

- `rtsp://<ip>/mpeg4/media.amp`
- `rtsp://<ip>/mpeg4/media.3gp`

Notes:

- AXIS 212 PTZ/-V supports QuickTime 6.5.1 (or later) and Real Player 10.5 (or later)
- QuickTime adds latency to the video and audio stream (up to 3 seconds)
- It may be possible to use other players to view the MPEG-4 stream using the paths above, although this is not guaranteed by Axis
- `<ip>` = IP address

Stream Types

Motion JPEG

This format uses standard JPEG still images for the video stream. These images are then displayed and updated at a rate sufficient to create a stream that shows constantly updated motion.

The Motion JPEG stream uses considerable amounts of bandwidth, but provides excellent image quality and access to each and every individual image contained in the stream. The recommended method of accessing Motion JPEG live video from AXIS 212 PTZ/-V is to use AXIS Media Control (AMC) in Microsoft Internet Explorer in Windows.

Note also that multiple clients accessing Motion JPEG streams can use different image settings.

MPEG-4

This is a video compression standard that makes good use of bandwidth, and which can provide high quality video streams at less than 1 Mbit/s.

Note:

All clients viewing the MPEG-4 stream must use the same image settings.

The MPEG-4 standard provides scope for a large range of different coding tools for use by various applications in different situations, and AXIS 212 PTZ/-V provides certain subsets of these tools. These are represented as **Video object types**, which are selected for use with different viewing clients. The supported video object types are:

- **Simple** - sets the coding type to H.263, as used by, for example, QuickTime™
- **Advanced Simple** - sets the coding type to MPEG-4 Part 2, as used by AMC (AXIS Media Control)

When using MPEG-4 it is also possible to control the bit rate, which in turn allows the amount of bandwidth usage to be controlled. CBR (Constant Bit Rate) is used to achieve a specific bit rate by varying the quality of the MPEG-4 stream. When using VBR (Variable Bit Rate), the quality of the video stream is kept as constant as possible, at the cost of a varying bit rate.

Important!

MPEG-4 is licensed technology. AXIS 212 PTZ/-V includes one viewing client license. Installing additional unlicensed copies of the viewing client is prohibited. To purchase additional licenses, contact your Axis reseller.

Alternative methods of accessing the video stream

Video/images from AXIS 212 PTZ/-V can also be accessed in the following ways:

- If supported by the client, AXIS 212 PTZ/-V can use Motion JPEG server push to display video. This option maintains an open HTTP connection to the browser and sends data as and when required, for as long as required.
- As single JPEG images in a browser. Enter, for example, the path: `http://<ip>/axis-cgi/jpg/image.cgi?resolution=CIF`
- Windows Media Player. This requires AMC and the MPEG-4 decoder to be installed. The paths that can be used are listed below, in the order of preference.
 - Unicast via RTP: `axrtpu://<ip>/mpeg4/media.amp`
 - Unicast via RTSP: `axrtsp://<ip>/mpeg4/media.amp`
 - Unicast via RTSP, tunneled via HTTP: `axrtsphttp://<ip>/mpeg4/media.amp`
 - Unicast via RTSP, tunneled via HTTPS: `axrtsphttps://<ip>/mpeg4/media.amp`
 - Multicast: `axrtpm://<ip>/mpeg4/media.amp`

Note:

<ip> = IP address

Configuration

AXIS 212 PTZ/-V is configured from the setup tools, which are available from the link in the web interface. The setup tools can be used by:

- administrators, who have unrestricted access to all the Setup tools
- operators, who have access to the Video Et Image, Live View Config and Event Configuration settings

See *Security*, on page 31 for more information on user access control.

The descriptions below show examples of the features available in AXIS 212 PTZ/-V. For details of each setting, please refer to the online help available from the setup tools. Click  to access the online help.

Accessing the configuration menus

Follow the instructions below to access the configuration menus from a browser.

1. Start your browser and enter the IP address or host name of the camera in the location/address field.
2. The Live View page is now displayed. Click **Setup** to display the menus that help you configure your network camera.

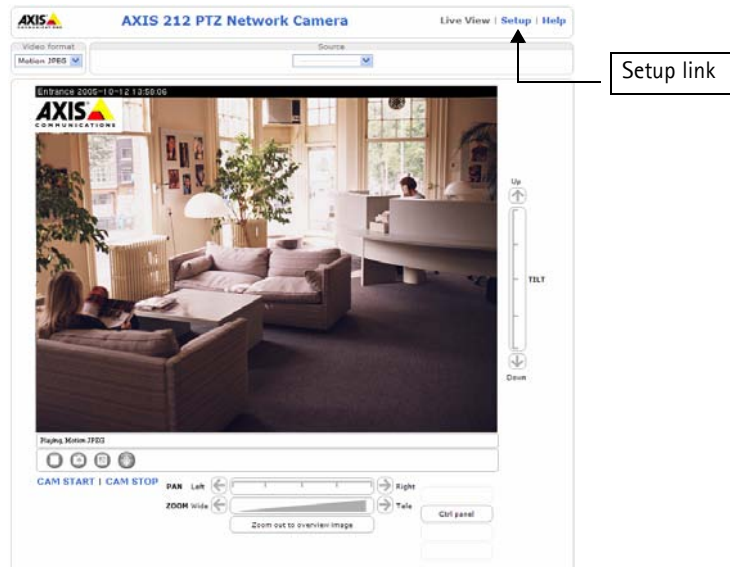

Video and Image settings

The screenshot shows the configuration interface for an AXIS 212 PTZ Network Camera. The left sidebar contains navigation links: Basic Configuration, Video & Image (with sub-links for Image, Overlay Image, and Advanced), Audio, Live View Config, PTZ Configuration, Event Configuration, System Options, and About. The main content area is titled 'Image Settings' and includes a help icon. It is divided into three sections: 'Image Appearance' with fields for Resolution (640x480 pixels), Compression (30), and White balance (Auto); 'Overlay Settings' with checkboxes for including overlay image, date, and time, and a text input field; and 'Video Stream' with radio buttons for 'Unlimited' and 'Limited to' (with fields for seconds and fps per viewer). A 'Test' button is located at the bottom right of the settings area, and 'Save' and 'Reset' buttons are at the bottom center.

Image

Image Appearance

Use these settings to change the image as required. The video image can be fine-tuned by adjusting the resolution, compression level, and the white balance.

The configuration of the video image will affect the camera's overall performance, depending on how it is used and on the available bandwidth. Setting a higher resolution and a lower compression improves video image quality, but increases the amount of bandwidth used. Please see the online help [?](#) for further information on these settings.

Overlay Settings

Use these settings to include:

- an image as an overlay, and/or
- the date and time, along with text of your own.

Text overlays are included in one line at the top or bottom of the video image. Image overlays can be placed anywhere in the video image.

See *Overlay Image*, on page 17 for instructions on how to upload an overlay image to AXIS 212 PTZ/-V.

Video Stream

Define the maximum **video stream** time per session in seconds, minutes or hours. When the set time has expired, a new stream can be started by refreshing the page in the browser. For unlimited video stream time, select the **Unlimited** radio button. Note that the maximum video stream time does not apply to clients connecting via multicast.

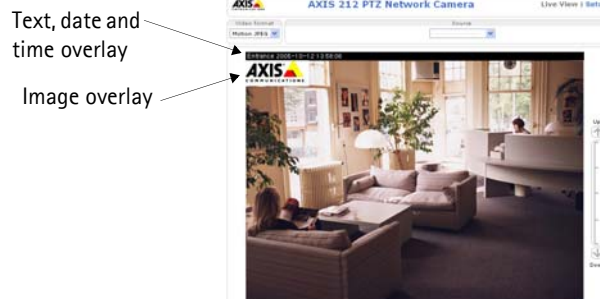

The **frame rate** allowed to each viewer can also be limited, to reduce bandwidth usage. To allow the highest available frame rate, select the **Unlimited** radio button.

For a preview of the image before saving, click **Test**. When satisfied with the settings, click **Save**. Please note that the preview image will be in JPEG format, even though the settings are valid both for Motion JPEG and MPEG-4.

Overlay Image

An overlay image is an image included in the video image. Follow these instructions to upload and use an overlay image:

1. Go to **Setup > Video & Image > Overlay Image** in your web interface.
2. To upload the image to AXIS 212 PTZ/-V, click the **Browse** button and locate it on your computer or server.
3. Click the **Upload** button and follow the on-screen instructions.
4. The image is now available in the **Use overlay image** drop-down list.
5. Click **Save**.
6. Go to **Setup > Video & Image** and modify the parameters under **Overlay Settings**.

Overlay image requirements:

Image Formats	Image Size
<ul style="list-style-type: none"> • Windows 24-bit BMP (full color) • Windows 4-bit BMP (16 colors) 	The height and width of the overlay image in pixels must be divisible by 4.

- The maximum overlay image size supported by AXIS 212 PTZ/-V is the same as the maximum image resolution. See *Technical Specifications*, on page 47.
- When a text overlay is also used, this reduces the amount of space available to the overlay image. To keep the text readable at lower resolutions, the text overlay occupies proportionally more and more space, i.e., 16 pixels in height at 640x480, 32 pixels at 320x240 and 64 pixels at 160x120.
- If the overlay is initially positioned so that part of it is outside the video image, it will be relocated so that it appears over the video image, i.e. the entire image is always displayed.

Please see the online help  for more information.

Advanced

Camera – Lighting Conditions

To optimize the lighting settings according to your requirements, modify the following settings:

- Color level - Select color or B/W
- Brightness - This can be adjusted in the range 0-100
- Sharpness - Controls the amount of sharpening applied to the image
- Exposure control - This setting is used to adapt to the amount/type of light being used
- Exposure zones - This setting determines which part of the image will be used to calculate the exposure. The Auto setting can be used in many situations, but for particular requirements, select one of the other predefined areas.

White balance

This is used to always try to make the colors in the image appear the same, to compensate for the different colors present in different light sources.

AXIS 212 PTZ/-V can be set to automatically identify the light source used and compensate for its color. Alternatively, the type of light source can be set manually.

From the drop-down list, select the white balance setting suitable for the lighting used for your camera.

For more information please refer to the online help .

Low Light Behavior

These settings determine how the camera will function in low light conditions. Adjustments made here affect image quality and are basically a measure of how much noise to allow in images. Please use the online help  for more information on each individual setting.

- Exposure priority
- Max exposure time
- Max gain

Please see the online help  for more information on these settings.

MPEG-4

GOV Settings – The GOV settings control the composition of the MPEG-4 video stream. Setting the **length** to a high value saves considerably on bandwidth. The **Cyclic refresh** parameter gives a smoother bit rate and can be useful if bandwidth is limited.

Bit Rate Control – Limiting the maximum bit rate is a good way of controlling the bandwidth used by the MPEG-4 video stream. Leaving the Maximum bit rate as unlimited will provide consistently good image quality, but at the expense of increased bandwidth usage whenever there is more activity in the image. Limiting the bit rate to a defined value will prevent excessive bandwidth usage, but images will be lost when the limit is exceeded.

Note that a maximum bit rate can be used for both variable and constant bit rates.

The bit rate type can be set as Variable Bit Rate (VBR) or Constant Bit Rate (CBR). VBR will adjust the bit rate according to the images' complexity, thus using a lot of bandwidth for a lot of activity in the image and less for lower activity in the monitored area.

CBR allows you to set a fixed Target bit rate that will consume a predictable amount of bandwidth, and which will not change whatever happens in the image.

As the bit rate would usually need to increase for increased image activity, but in this case cannot, the frame rate and image quality will be affected negatively. To go some of the way towards compensating for this, it is possible to prioritize either the frame rate or the image quality whenever the bit rate would normally need to be increased. Not setting a priority means the frame rate and image quality will be affected approximately equally.

MJPEG

Frame Size Control – In some situation the image size may get quite large due to low light or complex scenery. Adjusting the maximum frame size is a good way of controlling the bandwidth and storage used by the MJPEG video stream in these situations. Leaving the frame size at **Unlimited** will provide consistently good image quality at the expense of increased bandwidth and storage usage during low light. Limiting the frame size will prevent excessive bandwidth and storage usage, but image quality will suffer. To prevent increase in bandwidth and storage usage, the maximum frame size should be set to an optimal amount.

During ideal light conditions follow these instructions to optimize frame size:

1. Click the View button and a pop-up window appears with Frame size and Compression in the text field.
2. Note the current frame size. To calculate a maximum frame size add 10 - 20% to the current frame size.
3. Enter the calculated frame size in the Limited to... field.
4. Verify the quality of the image in low light. Increase the maximum frame size if needed.

Note:

The maximum frame size allowed increases compression in order to maintain a low frame size starting at the compression value set under **Image Settings > Image Appearance > Compression**. When compression is 100, the image cannot be made smaller. You may also need to adjust the Resolution setting if a smaller frame size is needed.

Audio Settings

AXIS 212 PTZ/-V can transmit audio to clients using either the built-in microphone or a connected external microphone and can play audio received from clients via a connected speaker.

Note:

The speaker connected to the audio output must have a built-in amplifier, for example, PC speakers.

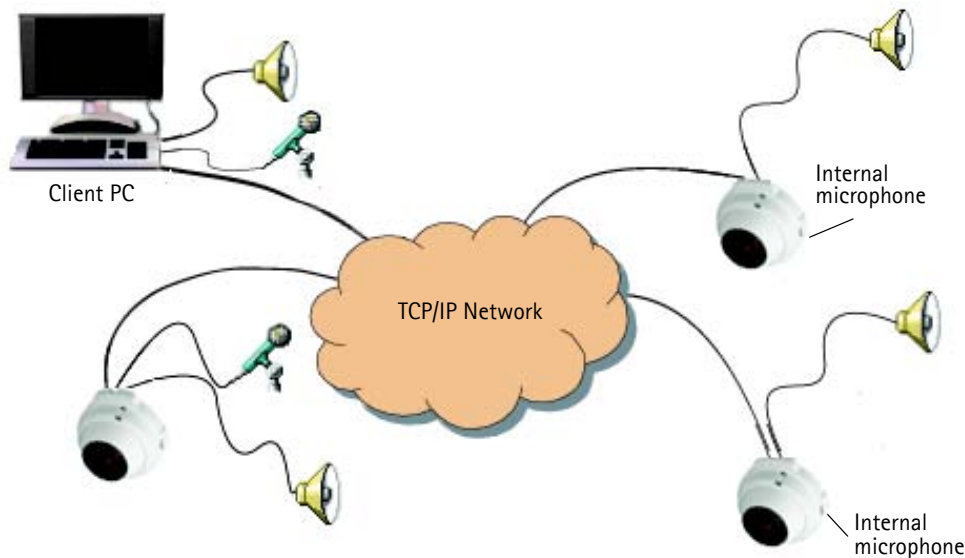

An example of a network using AXIS 212 PTZ/-V cameras to transmit audio and video across the network.

This section describes how to configure the basic audio settings for AXIS 212 PTZ/-V, for example, set the communication mode and adjust the sound levels in the microphone and speaker connected to the camera.

Enable Audio – Check this box to enable audio in AXIS 212 PTZ/-V.

Audio Channels – The **Half-duplex** mode transmits and receives audio in both directions, but only in one direction at a time. This means that you must select when to receive or transmit audio with the push-to-talk button. To speak, press and hold the button (check that the microphone is not muted). When done speaking, release the button and you will receive audio from the other end of the connection.

Note that the push-to-talk button is configured from AMC, see *AXIS Media Control*, on page 9. It is also possible to configure the push-to-talk button so that it toggles between speaking and listening modes.

When selecting the **Simplex – Network Camera speaker only** mode, the speaker connected to the camera will play audio, but no audio will be transmitted from the camera to other web clients. This could be used to for example, provide spoken instructions to a person seen in the camera. This mode requires you to use the push-to-talk button.

Simplex – Network Camera microphone only mode transmits audio only from AXIS 212 PTZ/-V to web clients. It will not receive audio from any other web clients. This can be used in remote monitoring, web attractions etc., to provide live audio, as well as video, of a monitored situation.

When using half-duplex, the **Send the sound from the active client to all other clients** option transmits the audio signal from the client that is talking to all the other clients.

Audio Input – Audio from an external microphone or a line source can be connected to the Audio in connector of AXIS 212 PTZ/-V. The audio source must be set to **Microphone** or **Line** depending on the connected device.

The **Enable microphone power** option provides DC power for an external microphone. If using a small electret condenser microphone such as a clip-on mic or a PC microphone, this option needs to be enabled.

Notes:

- To prevent unauthorized listening, the internal microphone can be disabled by inserting a plug in the Audio in connector.
- To use a high impedance dynamic microphone, DC power should not be enabled. DC power will not harm the microphone, but if you are uncertain, try switching it off and on. The default value is DC power enabled. To use a professional microphone requiring 48V phantom power, you need an external power supply and must use a balanced-unbalanced converter (audio transformer) in between.

If there are problems with the sound input being too low or high, adjust the **input gain** for the microphone attached to AXIS 212 PTZ/-V.

Select the desired audio **Encoding** format: AAC, G711, or G726.

Depending on the selected encoding, set the desired audio quality (**Bit rate**). The settings depend on the available bandwidth and the required audio quality.

AXIS 212 PTZ/-V can be set to trigger an event if the incoming sound level rises above, falls below or passes the set value. The **Alarm level** is set between 0-100%.

Audio Output – If the sound from the speaker is too low or high, adjust the **output gain** for the active speaker attached to AXIS 212 PTZ/-V.

When satisfied with the settings, click **Save**, or click **Reset** to revert to the previously saved settings.

Note:

To receive synchronized video and audio, it is recommended that the time settings in the camera and client PC are synchronized with an NTP Server. This is enabled in the camera under **System Options > Date & Time**. Please refer to the online help pages for more information.

Live View Config

Layout

AXIS 212 PTZ Network Camera Live View | Setup | Help

Live View Layout

Use Axis look
 Use custom settings [Configure...](#)

Default Video Format
 Video format: Motion JPEG

Show video format selection

Default Viewer
 Windows Internet Explorer: AMC (ActiveX)
 Other Browsers: Server push

Note: QuickTime is only used with MPEG-4. Motion JPEG will be shown with AMC in Windows Internet Explorer and with server push in other browsers.

Viewer Settings
 Show viewer toolbar
 Enable MPEG-4 decoder installation
 Show crosshair in PTZ joystick mode *
 Use PTZ joystick mode as default *
 Enable recording button

* Not applicable to AMC (ActiveX).

Action Buttons
 Show manual trigger button
 Show snapshot button

User Defined Links

<input type="checkbox"/> Show custom link 1	Use as: <input checked="" type="radio"/> cgi link <input type="radio"/> web link
Name: Custom link 1	URL: http://
<input type="checkbox"/> Show custom link 2	Use as: <input checked="" type="radio"/> cgi link <input type="radio"/> web link
Name: Custom link 2	URL: http://
<input type="checkbox"/> Show custom link 3	Use as: <input checked="" type="radio"/> cgi link <input type="radio"/> web link
Name: Custom link 3	URL: http://
<input type="checkbox"/> Show custom link 4	Use as: <input checked="" type="radio"/> cgi link <input type="radio"/> web link
Name: Custom link 4	URL: http://

Output Buttons
 Output 1: -----

[Save](#) [Reset](#)

These are the tools for deciding the layout of the Live View page. The layout can be set in 3 ways:

- Use Axis look - the layout is unchanged.
- Use custom settings - modify the default page with your own colors, images etc. Click Configure and see the following page.
- Own Home Page - Upload and use your own custom page as the default web page. Click Configure and see the Custom Settings page.

Custom settings

To change the background picture, banner, and colors, adjust the settings under **Modify the Axis look**.

To use your own file, for example a banner, first upload it by clicking the **Upload** button or enter the path to the file in the **External** field under **Modify the Axis Look**.

Upload Own Web Files – Your own web files, or background pictures, must first be uploaded to AXIS 212 PTZ/-V in order to be available for selection in the **Custom Settings** setup dialog. Once uploaded, the files are shown in the drop-down list.

1. Enter the path to the file located on your workstation or click the **Browse** button and locate the file.
2. Select the user level for the uploaded file. Setting the user access level means that you have complete control over which pages can be viewed by which users.
3. When the path is shown correctly in the text field, click the **Upload** button.

All uploaded files are shown in the list in the lower section of the page. To remove a file, check the box provided next to it and then click the **Remove** button.

- To use your uploaded file, click the radio button and select the file from the drop-down list by **Own**:
- To use an external file located somewhere other than in AXIS 212 PTZ/-V, click the radio button and enter the URL by **External**.

Note:

Unchecking the box for **Show setup link** removes the link from the camera's web pages. The setup tools will then only be accessible by entering the full setup address into the address/URL field of a browser, i.e. `http://<ip address>/operator/basic.shtml`

Own Home Page – To use a previously uploaded web page as the default page, select the **Use own home page** box option, and select the page from the drop-down list and click **OK**.

Default Video Format

Select the video format to use for the **Live View** page.

- Motion JPEG – Delivers a high quality video stream, from which individual images can be extracted and saved
- MPEG-4 – Video quality is comparable to Motion JPEG, but requires much less bandwidth

Default Viewer

From the drop-down lists, select the default method for viewing video images for your browser. The camera will attempt to show the video images in the selected video format and viewer. If this is not possible, the camera will override the settings and select the best available combination.

Browser	Viewer	Description
Windows Internet Explorer	AMC	Recommended viewer in Windows Internet Explorer (MPEG-4 / Motion JPEG).
	QuickTime	MPEG-4 only.
	Java applet	A slower imaging alternative to AMC. Requires one of the following installed on the client: <ul style="list-style-type: none"> • JVM (J2SE) 1.4.2 or higher • JRE (J2SE) 5.0 or higher
	Still image	Displays still images only. Hit the Refresh button in your browser to view a new image.
Other browsers	Server Push	Recommended viewer for other browsers (Motion JPEG).
	QuickTime	MPEG-4 only.
	Java applet	A slower imaging alternative to Server Push (Motion JPEG only).
	Still image	Displays still images only. Hit the Refresh button in your browser to view a new image.

Viewer Settings

Show viewer toolbar - Check this box to display the viewer toolbar under the image in your browser. The toolbar provides various controls for pausing the video stream, and switching to full screen mode.

Enable MPEG-4 decoder installation - By checking/unchecking this box, the administrator can enable or disable the installation of the MPEG-4 decoder included with AMC. This is used to prevent the installation of unlicensed copies. Further decoder licenses can be purchased from your Axis dealer.

Show crosshair in PTZ joystick mode - This cross indicates the center of the image when viewing the video stream in PTZ joystick mode.

Use PTZ joystick mode as default - Enabling this sets the PTZ mode to joystick. The mode can be changed temporarily on the PTZ Control Panel, but will default to joystick if this is selected.

Enable recording button - Enabling this button allows the user to start a recording directly from the Live View page. The recording is saved in the folder specified in the Recording tab in the AMC Control Applet. Note that this button is only available when viewing with AMC.

Action Buttons

Show manual trigger button - When displayed on the Live View page, clicking these buttons (On and Off) manually starts and stops all events that are configured to trigger in this way.

Show snapshot button - Enabling the display of the Snapshot button allows users to save a Motion JPEG snapshot from the video stream by clicking the button. This button is mainly intended for use with browsers other than Internet Explorer (IE), or when otherwise not using AXIS Media Control (AMC) to view the video stream. AMC provides its own snapshot button.

User-defined Links

Enter a descriptive name and enter the URL in the provided field. The link will appear on the Live View page.

User-defined CGI links can be used to issue HTTP API requests, for example, PTZ commands.

Example:

1. Check **Show custom link 1**.
2. Enter a descriptive name, for example, CAM START.
3. Select the **Use as cgi link** radio button and enter the cgi link in the field:

`http://192.168.0.125/axis-cgi/com/ptz.cgi?continuouspaniltmove=-30,-30`

4. Check **Show custom link 2**.
5. Enter a descriptive name, for example, CAM STOP.
6. Select the **Use as cgi link** radio button and enter the cgi link in the field:

`http://192.168.0.125/axis-cgi/com/ptz.cgi?continuouspaniltmove=0,0`

7. These links will appear in the web interface and can be used to control the PTZ camera.

For more information on the Axis HTTP API, see the Support / Developer pages on the Axis Website at <http://www.axis.com>

Please see the online help  for further details.

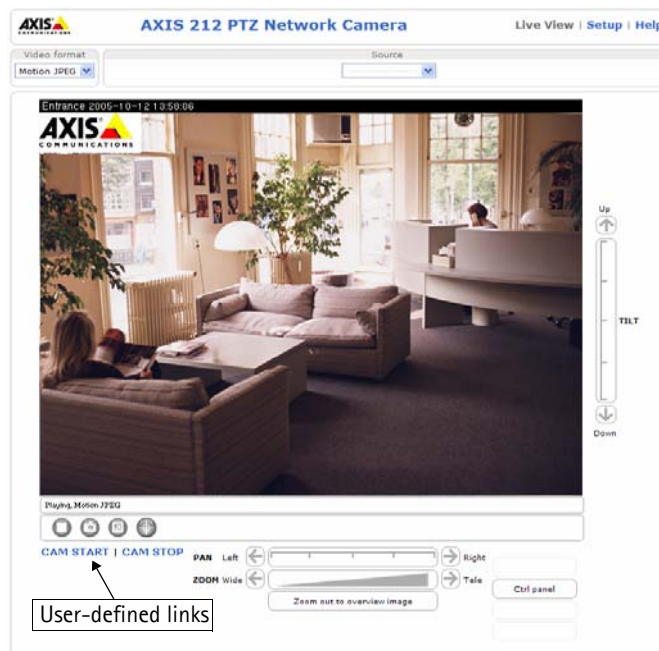

HTML Examples

You can add live video from AXIS 212 PTZ/-V to your own web site. The camera can transmit a Motion JPEG stream to up to 20 simultaneous connections, although an administrator can restrict this to fewer. If MPEG-4 is set as video format, multicasting is used and the video stream will be available for an unlimited number of viewers connected to the parts of the network where multicast is enabled. Please note that a separate MPEG-4 license is required for each viewer.

Select the preferred **Video Format** from the drop down list. The available options are Motion JPEG, MPEG-4 using AMC and MPEG-4 using QuickTime.

The Motion JPEG selection has additional settings for **Image type**, **Image size** and other optional settings to configure the video stream to suit your Web page. Click **Update** once satisfied.

The camera generates the required source code for your configuration. Copy this code and paste it into your own Web page code.

External Video

AXIS 212 PTZ/-V can display video images from other Axis network cameras and video servers, directly on the Live View page. These are known as **External Video sources**. Once configured, these external video sources are available from the drop-down list on the Live View page.

Click **Add** to open the External Video Source Setup dialog, which is used to make all the necessary settings. Enter the IP address or host name of the external video source you wish to add. Depending on the external source, select either MPEG-2, MPEG-4 or Motion JPEG as the type of video stream to receive.

Sequence Mode

The Live View page can be configured to rotate through selected preset positions and/or external video sources, in a set order or randomly.



Select the desired preset positions/sources and enter the time to display each position. Click **Save**.

The Sequence buttons will appear on the Live View page to enable the viewer to start and stop the sequence mode. For more information see *Preset Positions*, on page 26.

PTZ Configuration

In the PTZ Settings web page you can enable digital PTZ and create Preset Positions. You can also set the maximum zoom rate in Live view.

Preset Positions

A preset position is a pre-defined camera view that can quickly and easily be viewed.

From **Preset Position Setup**, use the Pan, Tilt and Zoom (PTZ) controls to steer the camera to the required position. When satisfied with the camera's position, enter a descriptive name. This camera position is then saved as a preset position.

AXIS 212 PTZ/-V will take the exact position when the preset's name is selected from the Preset position's drop-down list. Preset positions can be selected in **Live View**, from events and in **Sequence mode**.

One position can be set as the **Home** position, which is readily accessible by clicking on the **Home** button in both the Preset Position Setup window and the Live View window. The position's name will have (H) added, for example, Office Entrance (H).

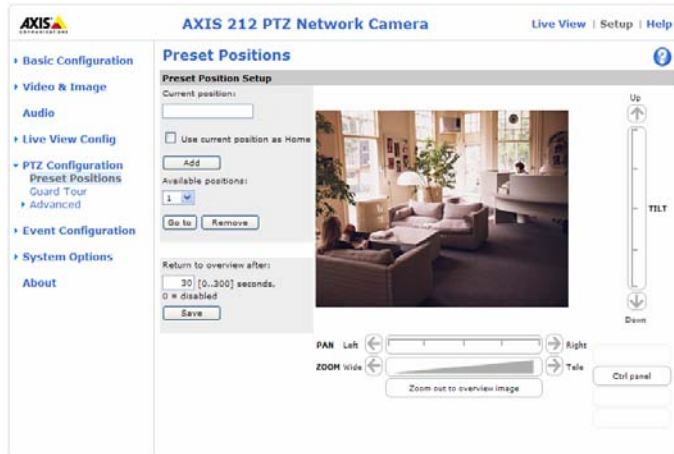

You can return AXIS 212 PTZ/-V to the overview image after a set time of viewing a preset position. The interval is configurable from 0 seconds (i.e. disabled) to 300 seconds. The default interval is 30 seconds.

Guard tour

A Guard Tour displays the video streams from different preset positions from cameras in the system, one-by-one, in a pre-determined order or randomly, and for configurable time periods. Once the preset position has been set, and added to the guard tour, the following settings can be made:

- View Time in seconds or minutes
- View Order (or Random)

Advanced – Ctrl Panel

This allows you to add a shortcut command button to the control panel on the **Live View** page. This requires the URL (path) to the command accessed via the HTTP API. See the online help [?](#) for more information.

Event Configuration

Pre-defined parameters, known as an Event or Event Type can trigger certain actions in the camera. A common event type is an alarm that prompts the camera to upload images. Many event types use an Event Server, to receive uploaded images.

An event that is triggered by a signal, such as a door switch, motion detection, or system event, is called a triggered event, see page 19.

A scheduled event runs at pre-programmed times.

An Action refers to what happens when the event occurs.

This section describes how to set up event servers and event types, i.e. how to configure the camera to perform certain actions when events (for example, alarms) occur.

Event Servers

Event Servers are used to receive for example, uploaded image files and/or notification messages. To set up Event server connections in your camera, go to **Setup > Event Configuration > Event Servers** and enter the required information for the required server type.

Server type	Purpose	Information required
FTP Server	<ul style="list-style-type: none"> Receives uploaded images 	<ul style="list-style-type: none"> Descriptive name of your choice Network address (IP address or host name) User Name and Password (for FTP server) Upload path for example, images/ Port number Use passive mode if there is a firewall between the camera and FTP server Use temporary file if your FTP server doesn't allow an existing file to be overwritten by a new file with the same name
HTTP Server	<ul style="list-style-type: none"> Receives notification messages Receives uploaded images 	<ul style="list-style-type: none"> Descriptive name of your choice URL (IP address or host name) User Name and Password (for HTTP server) Proxy address/Proxy port (if required) Proxy User Name and Password (if required)
TCP Server	<ul style="list-style-type: none"> Receives notification messages 	<ul style="list-style-type: none"> Descriptive name of your choice Network address (IP address or host name) User Name and Password (for TCP server) Port number

For details on each setting, please see the online help  available from each web page.

When the setup is complete, the connection can be tested by clicking the **Test** button (the connection test takes approximately 10 seconds).

Event Types

An **Event Type** describes how and when the camera will perform certain actions.

Example: If somebody passes before the camera and an event that uses motion detection has been configured to act on this, the camera can record and save images to an FTP server, and send a notification e-mail to a pre-configured e-mail address. Images can be sent as e-mail attachments.

Triggered Event

A Triggered event can be activated by:

- a push button connected to the camera's input port
- detected movement in a configured motion detection window
- a manually activated action, for example, from an action button in the web interface
- audio that is for example, louder than a specified level
- on restart (reboot) after for example, power loss

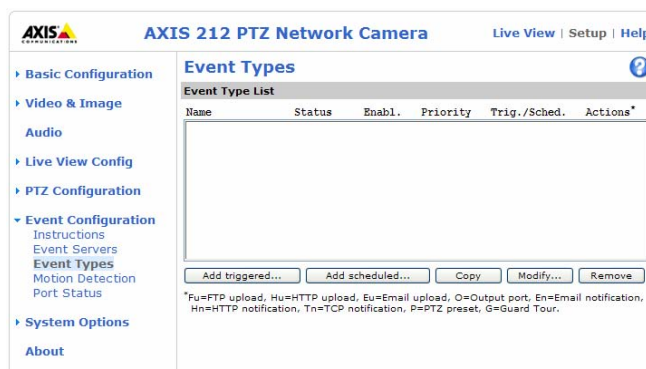

How to set up a triggered event

This example describes how to set up the camera to upload images when e.g the main door is opened:

1. Click **Add triggered** on the **Event types** page.
2. Enter a descriptive **name** for the event, for example, Main door open.
3. Set the **priority** - High, Normal or Low (see the online help).
4. Set the **Respond to Trigger...** parameters for when the event will be active, for example, only after office hours.
5. Select the trigger alternative from the **Triggered by...** drop-down list, for example, select Input ports, for a sensor connected to the door.
6. Set the **When Triggered...** parameters, i.e. define what the camera will do if the main door is opened for example, upload images to an FTP server or send an e-mail notification.
7. Click **OK** to save the Event in the Event Types list.

Please see the online help  for descriptions of each available option.

Note:

Up to 10 event types can be configured in the camera, and up to 3 of these can be configured to upload images. Files names can be formatted according to specific requirements. See File Naming & Date/Time Formats online help.

Pre-trigger and Post-trigger buffers

This function is very useful when checking to see what happened immediately before and/or after a trigger, for example, 30 seconds before and/or after a door was opened. Check the **Upload images** checkbox under **Event Types > Add Triggered... > Triggered by...** to expand the web page with the available options. All uploaded images are JPEG images.

Include pre-trigger buffer - contains images stored internally in the server from the time immediately preceding the trigger. Check the box to enable the pre-trigger buffer, enter the desired length of time and specify the required image frequency.

Include post-trigger buffer - contains images from the time immediately after the trigger. Configure as for pre-trigger.

Notes:

- Pre-trigger and Post-trigger buffers will be lost if the connection to the event server fails.
- Maximum length of the pre-/post-buffer depends on the video image size and selected frame rate.
- If the pre- or post-buffer is too large for the network camera's internal memory, the frame rate is reduced and no images will be uploaded. If this occurs, an entry will be created in the unit's log file.

Continue image upload (unbuffered) - enables the upload of video images for a fixed length of time. Specify the length of time for the uploaded recording, in seconds, minutes or hours, or for as long as the trigger is active. Finally, set the desired image frequency to the maximum (the maximum available) or to a specified frame rate. The frame rate will be the best possible, but might not be as high as specified, especially if uploading via a slow connection.

Scheduled Event

A Scheduled event can be activated at preset times, in a repeating pattern on selected weekdays.

Configuration example:

1. Click **Add scheduled** on the **Event types** page.
2. Enter a descriptive **name** for the event, for example, "Scheduled e-mail upload."
3. Set the **priority** (High, Normal or Low).
4. Set the **Activation Time** parameters (24h clock) when the event will be active, for example, start on Sundays at 13.00 with a duration of 12 hours.
5. Set the **When Activated...** parameters, i.e. set what the camera will do at the specified time, for example, send uploaded images to an e-mail address.
6. Click **OK** to save the Event in the Event Types list.

Please see the online help  for descriptions of each available option.

Motion Detection

Motion detection is used to generate an alarm whenever motion occurs (or stops) in the video image. A total of 10 Include and/or Exclude windows can be configured.

- **Included** windows target specific areas within the whole video image
- **Excluded** windows define areas within an Include window that should be ignored (areas outside Include windows are automatically ignored)

Once configured, the motion detection windows will appear in the list of available triggers, for triggering events. See *How to set up a triggered event* above.

Notes:

- Using the motion detection feature may decrease the camera's overall performance.
- The motion detection functionality is disabled during pan, tilt, zoom movement, and is enabled when you return to the overview view.

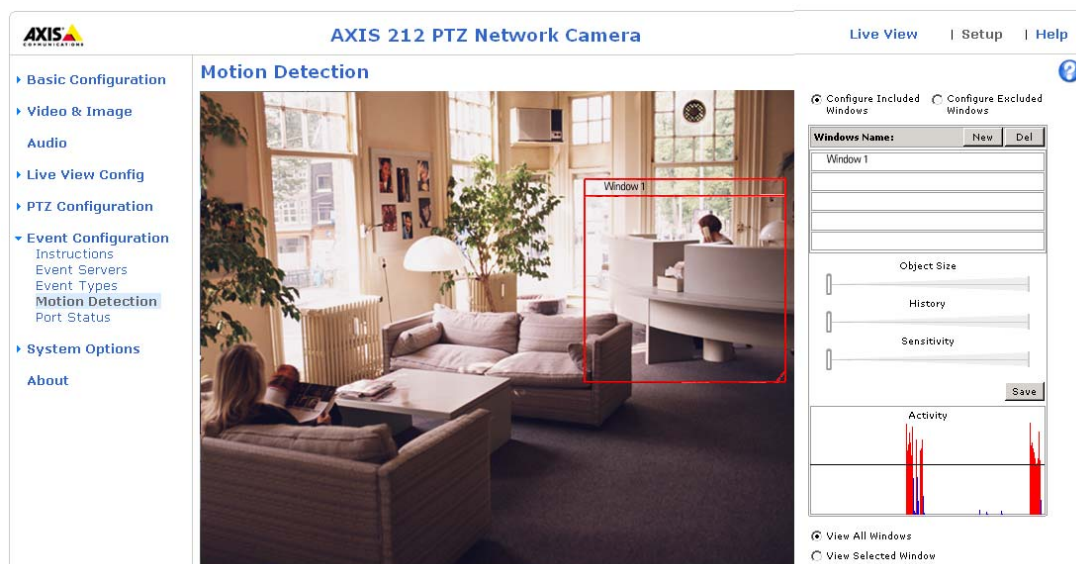

The screenshot displays the web interface for an AXIS 212 PTZ Network Camera. The main heading is "Motion Detection". On the left, a navigation menu lists various configuration options, with "Motion Detection" highlighted. The central area shows a live video feed of a living room with a red rectangular window labeled "Window 1" drawn over a person sitting at a desk. To the right of the video feed is a configuration panel. At the top of this panel, there are radio buttons for "Configure Included Windows" (selected) and "Configure Excluded Windows". Below this is a table for "Windows Name:" with columns for "New" and "Del", and a list containing "Window 1". Further down are three sliders for "Object Size", "History", and "Sensitivity", each with a "Save" button. At the bottom of the panel is an "Activity" graph showing red vertical bars representing motion events. At the very bottom, there are radio buttons for "View All Windows" (selected) and "View Selected Window".

Configuring Motion Detection

1. Click **Motion Detection** in the **Event Configuration** menu.
2. Click the **Configure Included Window** radio button and click **New**.
3. Enter a descriptive name under **Window name**.
4. Adjust the size (drag the bottom right-hand corner) and position (click on the text at the top and drag to the desired position).
5. Adjust the **Object size**, **History** and **Sensitivity profile** sliders (see table below for details). Any detected motion within an active window is then indicated by red peaks in the **Activity** window (the active window has a red frame).
6. Click **Save**.

To exclude parts of the Include window, click the **Configure Excluded Windows** button and position the Exclude window as required, within the Include window.

Please see the online help  for descriptions of each available option.

Motion Detection Parameters

The parameters available for motion detection are described briefly here. Please see the online help for complete descriptions.

Parameter	Size	History	Sensitivity
High	Only very large objects trigger motion detection	An object that appears in the region will trigger the motion detection for a long period	Ordinary colored objects against ordinary backgrounds will trigger the motion detection
Low	Even very small objects trigger motion detection	An object that appears in the region will trigger motion detection for only a very short period	Only very bright objects against a dark background will trigger motion detection
Default values	Low	Medium to High	Medium to High

Examples:

- Avoid triggering on small objects in the image by selecting a high size level.
- To trigger motion detection as long as there is activity in the area, select a high history level.
- To only detect flashing light, low sensitivity can be selected. In other cases, a high sensitivity level is recommended.

Port Status

Under **Event Configuration > Port Status** there is a list showing the status for the camera's input and output. This is for the benefit of **Operators**, who have no access to the **System Options** section.

Example: If the Normal state for a push button connected to an input is set to **Open circuit** – as long as the button is not pushed, the state is **inactive**. If the button is pushed, the state of the input changes to **active**.

System Options

Security

Users

User access control is enabled by default. An administrator can set up other users, by giving these user names and passwords. It is also possible to allow anonymous viewer login, which means that anybody may access the Live View page.

AXIS 212 PTZ/-V supports different methods of user authentication:

HTTP Basic Authentication – This authenticates the user by requesting a user name and a password. The exchange of network credentials is in simple base64 coding and is not encrypted.

HTTP Digest Authentication – This method also requests a user name and password, but the exchange of credentials is encrypted, which secures it against eavesdropping.

The user list in the Users page displays the authorized users and access levels:

- **Viewer** – the lowest level of access, which only allows the user access to the Live View page.
- **Operator** – an Operator can view the Live View page, create and modify event types and adjust certain other settings. The Operator does not have access to the Systems Options configuration pages.
- **Administrator** – an administrator has unrestricted access to the Setup Tools and can determine the registration of all other users.

To add a new user, click the **Add...** button and see the online help.

User Settings – check the relevant checkboxes to enable:

- **Enable anonymous viewer login** – allows any viewer direct access to the Live View page.
- **Maximum number of simultaneous viewers** – enter a value here to restrict the number of unicast viewers accessing the unit. This is useful if you need to save on bandwidth. (Note that all multicast viewers count as 1 viewer.)

IP Address Filter

Enable IP Address Filtering to allow or deny access to AXIS 212 PTZ/-V. Once enabled, the IP addresses in the list will be allowed or denied access according to the choice made in the drop-down list **Allow/Deny** the following IP addresses.

The administrator can add up to 256 IP address entries to the list (a single entry can contain multiple IP addresses). The users from these IP addresses need to be specified in the user list with the appropriate access rights. This is done from **Setup > System Options > Security > Users**.

Referrals – To prevent unauthorized clients from including the video stream from the cameras into external Web pages, check the **Referrals** checkbox and enter the IP address or Host name of the computer that hosts the Web pages with the included video stream. Several IP addresses/host names can be defined and are separated by semicolons (;). This option is only applicable to Motion JPEG video streams.

Notes:

- If the referrals feature is enabled and you wish to also allow normal access to the Live View page, the product's own IP address or host name must be added to the list of allowed referrers.
- Restricting referrers has no effect on an MPEG-4 video stream. To restrict an MPEG-4 stream, IP address filtering must be enabled.
- Restricting referrers is of greatest value when not using IP address filtering. If IP address filtering is used, then the allowed referrers are automatically restricted to those allowed IP addresses.

HTTPS

AXIS 212 PTZ/-V supports encrypted browsing using HTTPS.

A **self-signed certificate** can be used until a Certificate Authority-issued certificate has been obtained. Click the **Create self-signed Certificate** button to install a self-signed certificate. Although self-signed certificates are free and offer some protection, true security will only be implemented after the installation of a signed certificate issued by a certificate authority.

A signed certificate can be obtained from an issuing Certificate Authority by clicking the **Create Certificate Request** button. When the signed certificate is returned, click the **Install signed certificate** button to import the certificate. The properties of any certificate request currently resident in the camera or installed can also be viewed by clicking the **Properties...** button. The HTTPS Connection Policy must also be set in the drop-down lists to enable HTTPS in the camera.

For more information, please refer to the online help. 

802.1x

IEEE 802.1x is a standard for port-based Network Admission Control providing secure authentication of wired and wireless network devices. IEEE 802.1X is based on EAP (Extensible Authentication Protocol).

To access a network protected by IEEE 802.1x, devices must authenticate themselves. The authentication is performed by a third-party entity called an authentication server, typically a RADIUS server, examples of which are FreeRADIUS and Microsoft Internet Authentication Service.

In Axis' implementation, the network device and the authentication server authenticate themselves with the help of digital certificates using EAP-TLS (Extensible Authentication Protocol – Transport Layer Security). The certificates are provided by a **Certification Authority (CA)**. You need:

- a CA certificate to validate the identity of the authentication server
- a CA-signed client certificate and a private key to authenticate the network device

To allow the network device to access a network protected by IEEE 802.1X:

1. Obtain a CA certificate, a client certificate and a client private key (contact your network administrator).
2. Go to **Setup > System Options > Security > 802.1X** and upload the CA certificate, the client certificate and the client private key.
3. Under **Settings**, select the EAPOL version, provide your EAP identity and private key password.
4. Check the box to enable 802.1X and click **Save**.

Certificates

CA certificate – The CA certificate is used to validate the identity of the authentication server. Enter the path to the certificate directly, or locate the file using the **Browse** button. Then click **Upload**. To remove a certificate, click **Remove**.

Client certificate and Client private key – The client certificate and private key are used to authenticate the network device. They can be uploaded as separate files or in one combined file (e.g. a PFX file or a PEM file). Use the **Client private key** field if uploading one combined file. For each file, enter the path to the file, or locate the file using the **Browse** button. Then click **Upload**. To remove a certificate, click **Remove**.

Settings

EAPOL version – Select the EAPOL version (1 or 2) as used in your network switch.

EAP identity – Enter the user identity (maximum 16 characters) associated with your certificate.

Private key password – Enter the password (maximum 16 characters) for the private key.

Enable 802.1x – Check the box to enable the IEEE 802.1X protocol.

Date & Time

Current Server Time – displays the current date and time (24h clock). The time can be displayed in 12h clock format in the Overlay (see below).

New Server Time – Select your time zone from the drop-down list. If you want the server clock to automatically adjust for daylight savings time, select **Automatically adjust for daylight saving time changes**.

From the **Time Mode** section, select the preferred method to use for setting the time:

- **Synchronize with computer time** – sets the time from the clock on your computer.
- **Synchronize with NTP server** – the camera will obtain the time from an NTP server every 60 minutes.
- **Set manually** – this option allows you to manually set the time and date.

Note:

If using a host name for the NTP server, a DNS server must be configured under **TCP/IP** settings. See **Network > TCP/IP** below.

Date & Time Format Used in Images – specify the formats for the date and time (12h or 24h) displayed in the video streams.

Use the predefined formats or use your own custom date and time formats. See **Advanced File Naming & Date/Time Formats** in the online help  for information on how to create your own file formats.

Network

Basic TCP/IP Settings

IP Address Configuration – AXIS 212 PTZ/-V supports both IP version 4 and IP version 6. Both versions may be enabled simultaneously, and at least one version must always be enabled.

When using IPv4, the IP address can be set automatically via DHCP, or a static IP address can be set manually.

If IPv6 is enabled, your camera will receive an IP address according to the configuration in the network router.

There are also options for setting up notification of changes in the IP address, and for using AXIS Internet Dynamic DNS Service. For more information on setting the IP address, please see the online help.

Notes:

- To receive notification whenever the camera's IP address changes (via for example, DHCP), configure the options for notification of IP address change. See **Services** below.
- Alternatively, if your DHCP server can update a DNS server, you can access the AXIS 212 PTZ/AXIS 212 PTZ-V by host name which is always the same, regardless of the IP address.

Services – Enable ARP/Ping setting of IP address – The IP address can be set using the ARP/Ping method, which associates the unit's MAC address with an IP address. Check this box to enable the service. Leave disabled to prevent unintentional resetting of the IP address.

Notes:

- The ARP/Ping service is automatically disabled 2 minutes after the unit is started, or as soon as an IP address is set.
- Pinging the unit will still be possible when this service is disabled.

Options for notification of IP address change – if the IP address for the camera changes, for example, automatically by DHCP, you can choose to be notified of the change. Click **Settings...** and enter the required information.

AXIS Internet Dynamic DNS Service – use AXIS Internet Dynamic DNS service to assign a host name for easy access to your AXIS 212 PTZ/-V (requires Internet access).

Click **Settings** to register your AXIS 212 PTZ/-V with AXIS Internet Dynamic DNS service, or to modify the existing settings (requires access to the Internet). The domain name currently registered at AXIS Internet Dynamic DNS service for your product can be removed at any time.

For more information, please refer to the online help.

Advanced TCP/IP Settings

DNS Configuration – DNS (Domain Name Service) provides the translation of host names to IP addresses on your network.

Obtain DNS server address via DHCP – automatically use the DNS server settings provided by the DHCP server. Click the **View** button to see the current settings.

Use the following **DNS server address** – enter the desired DNS server by specifying the following:

- **Domain name** – enter the domain(s) to search for the host name used by AXIS 212 PTZ/-V. Multiple domains can be separated by semicolons (;). The host name is always the first part of a Fully Qualified Domain Name, for example, **myserver** is the host name in the Fully Qualified Domain Name **myserver.mycompany.com** where **mycompany.com** is the Domain name.
- **Primary DNS server** – enter the IP address of the primary DNS server.
- **Secondary DNS server** – will be used if the primary DNS server is unavailable.

Domain name – enter the domain(s) to search for the host name used by AXIS 212 PTZ/-V. Multiple domains can be separated by semicolons (;). The host name is always the first part of a Fully Qualified Domain Name, for example, **myserver** is the host name in the Fully Qualified Domain Name **myserver.mycompany.com** where **mycompany.com** is the Domain name.

DNS servers – enter the IP addresses of the primary and secondary DNS servers.

NTP Configuration – Obtain NTP server address via DHCP – check this radio button to automatically look up and use the NTP server settings as provided by DHCP. Click the **View** button to see the current settings.

Use the following **NTP server address** – to make manual settings, check this radio button and enter the host name or IP address of the NTP server.

Host Name Configuration – AXIS 212 PTZ/-V can be accessed using a host name, instead of an IP address. The host name is usually the same as the assigned DNS Name. It is always the first part of a Fully Qualified Domain Name and is always one word, with no period. For example, **myserver** is the host name in the Fully Qualified Domain Name **myserver.mycompany.com**.

Enabling dynamic DNS updates allows you to alias a dynamic IP address to a static host name, allowing your computer to be more easily accessed from various locations on the Internet. Outside users can always access your server using the associated DNS name regardless of the WAN IP. The DNS server used by the user and/or the DNS server responsible for the domain in use must support RFC2136 and allow updates from the camera.

The **TTL (Time To Live)** value determines how long (in seconds) the reply from the DNS server should be remembered when checking that the domain name for the registered IP address is still valid.

Link-Local IPv4 Address – Link-Local Address is enabled by default and assigns AXIS 212 PTZ/-V an additional IP address for the UPnP protocol. AXIS 212 PTZ/-V can have both a Link-Local IP and a static/DHCP IP address at the same time – these will not affect each other. See *UPnP™*, on page 37.

HTTP – The default HTTP port number (80) can be changed to any port within the range 1024-65535. This is useful for example, simple security port mapping.

HTTPS – The default HTTPS port number (443) can be changed to any port within the range 1024-65535. HTTPS is used to provide encrypted web browsing.

NAT traversal (port mapping) – A broadband router allows devices on a private network (LAN) to share a single connection to the Internet. This is done by forwarding network traffic from the private network to the "outside" i.e. the Internet. Security on the private network (LAN) is increased since most broadband routers are pre-configured to stop any attempts to access the private network (LAN) from the public network/Internet.

Use **NAT traversal** when your AXIS 212 PTZ/-V is located on an intranet (LAN) and you wish to make it available from the other (WAN) side of a NAT router. With NAT traversal properly configured, all HTTP traffic to an external HTTP port in the NAT router will be forwarded to the camera.

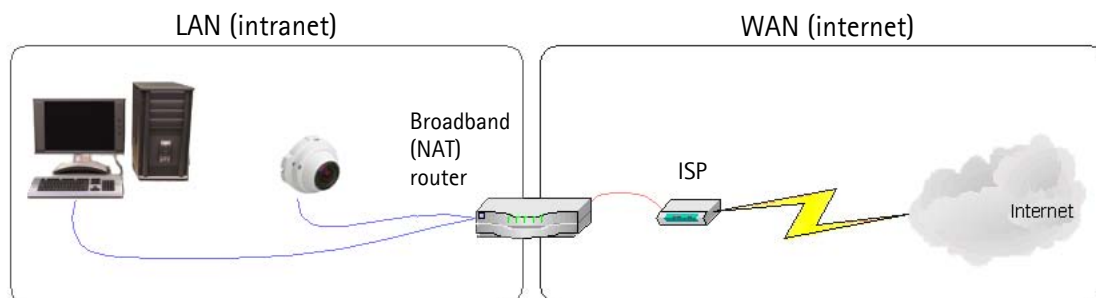

Notes:

- For NAT traversal to work, this must also be supported by the broadband router.
- The broadband router has many different names: "NAT router", "Network router", "Internet Gateway", "Broadband sharing device" or "Home firewall" but the essential purpose of the device is the same.

Enable/Disable – When enabled, AXIS 212 PTZ/-V will attempt to configure port mapping in a NAT router on your network, using UPnP™. Note that UPnP™ must be enabled in the camera (see **System Options > Network > UPnP**).

AXIS Internet Dynamic DNS Service – Use this free service to assign a host name (user-friendly name) for easy access to your camera. If the IP address of the camera or NAT router changes, the AXIS Internet Dynamic DNS Service will automatically be updated with the new IP address.

Use manually selected NAT router – Select this option to manually select a NAT router and enter the IP address for the router in the field provided.

If a router is not manually specified, AXIS 212 PTZ/-V will automatically search for NAT routers on your network. If more than one router is found, the default router will be selected.

Alternative HTTP port – Select this option to manually define an external HTTP port. Enter the port number in the field provided. If no port is entered here a port number will automatically be selected when NAT traversal is enabled.

Notes:

- An alternative HTTP port can be used/be active even if NAT traversal is disabled. This is useful if for example, your NAT router does not support UPnP and you need to manually configure port forwarding in the NAT router.
- If a manually selected port is already in use, another will automatically be selected.
- When the port is selected automatically it will be displayed in this field. This can be changed by entering a new port number and clicking Save.

FTP – The FTP server running in AXIS 212 PTZ/-V enables the upload of for example, new firmware, user applications, etc. Check the box to enable the service.

RTSP – The RTSP protocol allows a connecting client to start an MPEG-4 stream. Enter the RTSP port number to use. The default setting is 554.

Network Traffic – The default connection setting is **Auto-negotiate**, which means that the correct speed is automatically selected. If necessary, you can set the connection speed by selecting it from the drop-down list: 10BaseT (Half/Full Duplex), or 100BaseTX (Half/Full Duplex).

Maximum bandwidth – Specify, in Mbit/s or Kbit/s, the maximum bandwidth that AXIS 212 PTZ/-V is allowed to use on your network. This is a useful function when connecting AXIS 212 PTZ/-V to busy or heavily loaded networks. The default setting is **Unlimited**. For more information, please refer to the online help.

SOCKS

SOCKS is a networking proxy protocol. AXIS 212 PTZ/-V can be configured to use a SOCKS server to reach networks on the other side of a firewall/proxy server. This functionality is useful if AXIS 212 PTZ/-V is located on a local network behind a firewall, but notifications, uploads, alarms, etc., need to be sent to a destination outside the local network (for example, to the Internet).

QoS (Quality of service)

Quality of Service (QoS) provides the means to guarantee a certain level of a specified resource to selected traffic on a network. Quality can be defined as for example, a maintained level of bandwidth, low latency, no packet losses, etc. The main benefits of a QoS-aware network can be summarized as:

- the ability to prioritize traffic and thus allow critical flows to be served before flows with lesser priority.
- greater reliability in the network, thanks to the control of the amount of bandwidth an application may use, and thus control over bandwidth races between applications.

The QoS in Axis network video products marks the data packets for various types of network traffic originating from the product. This makes it possible for network routers and switches to for example, reserve a fixed amount of bandwidth for these types of traffic. The following types of traffic are marked:

- live video
- live audio
- event/alarm traffic
- management network traffic

QoS Settings

For each type of network traffic supported by your Axis network video product, enter a DSCP (Differentiated Services Codepoint) value. This value is used to mark the traffic's IP header. When the marked traffic reaches a network router or switch, the DSCP value in the IP header tells the router or switch which type of treatment to apply to this type of traffic, for example, how much bandwidth to reserve for it.

Note that DSCP values can be entered in decimal or hexadecimal form, but saved values are always shown in decimal.

For more information on Quality of Service, please see the Axis support web at www.axis.com/techsup

SMTP (email)

Enter the host names or addresses for your primary and secondary mail servers in the fields provided, to enable the sending of notifications and image/video email messages from the camera to predefined addresses via SMTP.

If your mail server requires authentication, check the box for **Use authentication to log in to this server** and enter the necessary information.

SNMP

The Simple Network Management Protocol (SNMP) allows remote management of network devices. Depending on the level of security required, select the version of SNMP to use. The three levels of security are:

- SNMP V1 – includes no security.
- SNMP V2c – uses very simple security. The community name can be specified as a password for read or read/write access to all supported SNMP objects. The community is the group of network devices using SNMP.
- SNMP V3 – provides encryption and secure passwords. HTTPS must be enabled.

Traps for SNMP v1/v2

Traps are used by the camera to send messages to a management system for important events or status changes.

Select **Enable traps** to activate trap reporting. Enter the email address the trap message is to be sent to, and specify the **Trap community** that should receive the message.

There are four types of traps available for the network camera.

- Cold start
- Warm start
- Link up
- Authentication failed

SNMP V3 – provides encryption and secure passwords. HTTPS must be enabled. To use traps with SNMP v3 an SNMP v3 management application is required.

If the Enable SNMP v3 option is enabled, provide the Initial user password. Note that the initial password is activated only when HTTPS is enabled and can only be set once.

If HTTPS is enabled, SNMP v1 and SNMP v2c should be disabled.

When SNMP configuration is ready, click **Save** to use the new settings or **Reset** to return to the default values.

UPnP™

The camera includes support for UPnP™, which is enabled by default. If also enabled on your computer, the camera will automatically be detected and a new icon will be added to "My Network Places."

Note:

UPnP must also be enabled on your Windows XP. To do this, open the Control Panel from the Start Menu and select Add/Remove Programs. Select Add/Remove Windows Components and open the Networking Services section. Click **Details** and then select UPnP as the service to add.

RTP

These settings are the port range, IP address, port number (video and audio), and Time-To-Live value to use for the video stream(s) in multicast MPEG-4 format. Only certain IP addresses and port numbers should be used for multicast streams. For more information, please see the online help.

Bonjour

AXIS 212 PTZ/-V includes support for Bonjour. When enabled, the camera is automatically detected by operating systems and clients that support Bonjour.

Ports & Devices

I/O Ports – the pinout, interface support and the control and monitoring functions provided by this connector are described in *The I/O Terminal Connector*, on page 40.

LED

The Status indicator LED on the front of the camera can be set to flash at a configurable interval (or to not light up at all) whenever the unit is accessed. For a listing of all LED behavior, see page 7, or the online help.

Note that the LED does not flash when the stream is retrieved using MPEG-4 multicast.

Maintenance

- Restart - The camera is restarted without changing any of the settings.
- Restore - The camera is restarted and most current settings are reset to factory default values. The settings that will not be reset are as follows:
 - the boot protocol (DHCP or static)
 - the static IP address
 - the default router
 - the subnet mask
- Default - The default button should be used with caution. Pressing this will return all of the camera's settings to the factory default values (including the IP address)

Upgrade Server - See *Upgrading the Firmware*, on page 42.

Backup - To take a backup of all of the parameters, and any user-defined scripts, click this button. If necessary, it will then be possible to return to the previous settings, if settings are changed and there is unexpected behavior.

Restore - Click the **Browse** button to locate the saved backup file (see above) and then click the **Restore** button. The settings will be restored to the previous configuration.

Note:

Backup and **Restore** can only be used on the same unit running the same firmware. This feature is not intended for the configuration of multiple units or for firmware upgrades.

Support

The **Support overview** page provides valuable information on troubleshooting and contact information.

System Overview - Provides a quick look over the camera's status and settings. Information that can be found here includes the camera's Firmware version, IP address, Security, Event and Image settings and Recent log items. Many of the captions are also links to the proper **Setup** page to conveniently make adjustments in the cameras settings.

Logs & Reports - When contacting Axis support, please be sure to provide a valid Server Report with your query.

Information - the Server Report and Parameter List may prove useful when troubleshooting a problem or when contacting the Axis support web.

System Log - Provides information about system events.

Access Log - By default, the Access Log lists all failed attempts to access the camera but can be configured to list all connections to the camera, whether successful or not. The Access Log is useful for various purposes such as tracking all access to the camera, simple web attraction tracking, system analysis and troubleshooting.

Server Report - Provides information about the server status and should always be included when requesting support.

Parameter List - Shows the unit's parameters and their current settings.

Connection List - Lists all clients that are currently accessing video. It is also used for system analysis and troubleshooting.

Crash Report - Generates an archive with debug information for all running applications. This will typically take several minutes to generate. Technical support may ask for this information if you report a problem.

Configuration

Log Level for Log Files - From the drop-down list, select the level of information to be added to the Log file.

Log Level for Email - From the drop-down list, select the level of information to send as email and enter the destination email address.

Advanced

Scripting - This is a powerful and advanced function that enables the use of custom scripts.

Caution!

Improper use may cause unexpected behavior or even cause loss of contact with the unit. If a script does cause problems, reset the unit to its factory default settings. A backup file may be of use to return the unit to its latest configuration. Axis strongly recommends that you do not use this function unless you fully understand the consequences. Axis support does not provide assistance for problems with customized scripts.

For more information, please visit the Developer pages at www.axis.com/developer

Plain Config - This function is for the advanced user with experience of Axis network camera configuration. All parameters can be set and modified from this page. Help is available from the standard help pages.

Resetting to the Factory Default Settings

To reset the camera to the original factory default settings, go to the **System Options > Maintenance** web page (as described in *Maintenance*, on page 38) or use the **Control button** on the underside of the camera (see page 6) as described below:

Using the Control Button

To reset the camera to the factory default settings using the Control Button:

1. Disconnect the power adapter.
2. Press and hold the Control button while reconnecting the power.
3. Keep the Control button pressed until the **Status Indicator** color changes to amber (this may take up to 15 seconds).
4. Release the Control button.
5. When the Status Indicator changes to Green (which may take up to 1 minute), the process is complete and the camera has been reset. The unit will now have the default IP address 192.168.0.90

Note:

Resetting to the factory default settings using the Control Button will cause all parameters (including the IP address) to be reset. Refer to *Maintenance*, on page 38 for other methods that do not reset the IP address.

The I/O Terminal Connector

Pinout and Interface

The 4-pin I/O terminal connector provides the interface to:

- 1 transistor output
- 1 digital input
- Auxiliary power
- Ground (GND)

The terminal connector is used in applications - for example, motion detection, event triggering, time lapse recording, alarm notification via email, and image storage to FTP locations.

- **Input** - for connecting for example, a push button. If the button is pressed, the state changes and the input becomes active (shown under **Event Configuration > Port Status**).
- **Output** - connects for example, an alarm device that can be activated by Output buttons on the **Live View** page, or by an **Event Type**. The output will show as **active (Event Configuration > Port Status)** if the alarm device is activated.

I/O terminal connector:

Pin	Function	Description
1	GND	Ground
2	3.3V DC	Can be used to power auxiliary equipment, max 50mA.
3	Digital Input	Connect to GND to activate, or leave floating (or unconnected) to deactivate.
4	Transistor Output	With a maximum load of 50mA and a maximum voltage of 24V DC, this output has an open-collector NPN transistor with the emitter connected to the GND pin. If used with an external relay, a diode must be connected in parallel with the load, for protection against voltage transients.

Connect input/output devices to the camera as follows:

1. Attach the cables for the device securely to the supplied green connector block.
2. Once the cables are connected, push the connector block into the green terminal connector on the camera.

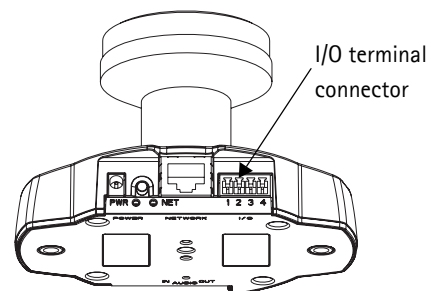

AXIS 212 PTZ/-V - The I/O Terminal Connector

Terminal Connectors - Schematics

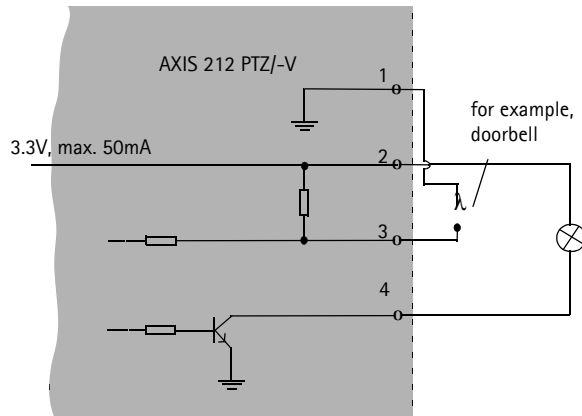

Troubleshooting

Checking the Firmware

Firmware is software that determines the functionality of AXIS 212 PTZ/-V. One of your first actions when troubleshooting a problem should be to check the currently installed firmware version. The latest version may contain a correction that fixes your particular problem. The current firmware version in your camera can be seen on the page **Setup > Basic Configuration**.

Upgrading the Firmware

When you upgrade the firmware with a file from Axis Web site, your camera will receive the latest available functionality. Always read the upgrade instructions and release notes available with each new release, before updating the firmware.

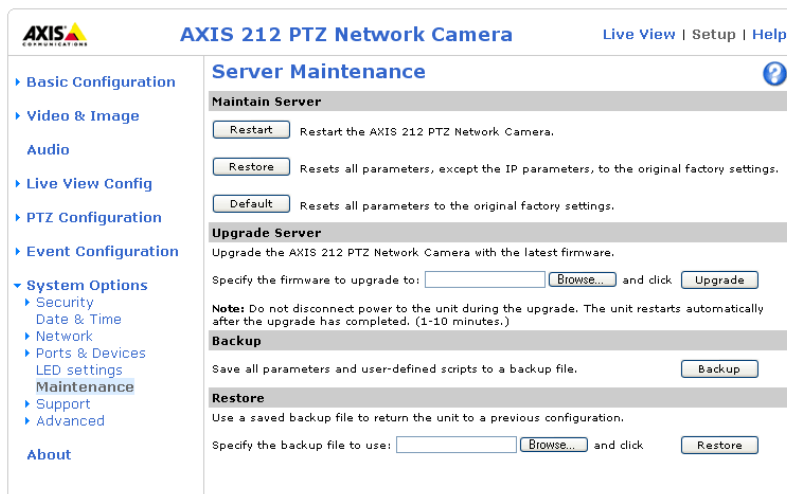

1. Save the firmware file to your computer. The latest version of the firmware is available free of charge from Axis Web site at www.axis.com/techsup
2. Go to **Setup > System Options > Maintenance** in the camera's Web pages.
3. In the **Upgrade Server** section, browse to the desired firmware file on your computer. Click **Upgrade**.

Notes:

- Preconfigured and customized settings will be saved when the firmware is upgraded (as long as the same features are available in the new firmware) although this is not guaranteed by Axis Communications.
- After starting the upgrade process, always wait at least 5-10 minutes before restarting the camera, even if you suspect the upgrade has failed.
- Your dealer reserves the right to charge for any repair attributable to faulty upgrading by the user.

The software tool **AXIS Camera Management** can be used for multiple upgrades. Please visit Axis website at www.axis.com for more information.

Emergency Recovery Procedure

If power or the network connection to the camera is lost during the upgrade, the process will fail and the unit will become unresponsive. A flashing red Status LED indicates a failed upgrade. To recover the unit, follow the steps below. The serial number is found on the label attached to the bottom of the camera.

1. **UNIX/Linux** - From the command line, type the following:

```
arp -s <IP address of camera> <Serial number> temp
ping -s 408 <IP address of camera>
```

Windows - From a command/DOS prompt, type the following:

```
arp -s <IP address of camera> <Serial number>
ping -l 408 -t <IP address of camera>
```

2. If the unit does not reply within a few seconds, restart it and wait for a reply. Press CTRL+C to stop Ping.
3. Open a browser and type in the camera's IP address. In the page that appears, use the **Browse** button to select the upgrade file to use, for example, axis212ptz.bin. Then click the Load button to restart the upgrade process.
4. After the upgrade has completed (1-10 minutes), the unit will automatically restart and show a steady green on the Power and Status LEDs and flashing green or amber on the Network LED.
5. Referring to the installation guide, reinstall the camera.

If the emergency recovery procedure does not get the camera up and running again, please contact Axis support at www.axis.com/techsup/

Axis Support

If you contact Axis support, please help us to help you solve your problems, by providing the server report, the log file and a brief description of the problem.

Server Report - go to **Setup > System Options > Support Overview**. The server report contains important information about the server and its software, as well as a list of the current parameters.

The **Log file** is available from **Setup > System Options > Logs & Reports**. The Log file records events in the unit since the last system restart and can be a useful diagnostic tool when troubleshooting.

Symptoms, Possible Causes and Remedial Actions

Problems setting the IP address	
When using ARP/Ping	Try the installation again. The IP address must be set within two minutes after power has been applied to the camera. Ensure the Ping length is set to 408. See the Installation Guide.
The camera is located on a different subnet	If the IP address intended for the camera and the IP address of your computer are located on different subnets, you will not be able to set the IP address. Contact your network administrator to obtain an appropriate IP address.
The IP address is being used by another device	Disconnect the camera from the network. Run the Ping command. (In a Command/DOS window, type ping and the IP address of the unit). If you receive: Reply from <IP address>: bytes = 32; time = 10 ms..... - this means that the IP address may already be in use by another device on your network. You must obtain a new IP address and reinstall the unit. If you see: Request timed out - this means that the IP address is available for use with your camera. In this case, check all cabling and reinstall the unit.
Possible IP address conflict with another device on the same subnet	The static IP address in the camera is used before the DHCP server sets a dynamic address. This means that if the same default static IP address is also used by another device, there may be problems accessing the camera. To avoid this, set the static IP address to 0.0.0.0.
The camera cannot be accessed from a browser	
The IP address has been changed by DHCP	1) Move the camera to an isolated network or to one with no DHCP or BOOTP server. Set the IP address again, using the AXIS IP Utility (see the Installation Guide) or the ARP/Ping commands. 2) Access the unit and disable DHCP in the TCP/IP settings. Return the unit to the main network. The unit now has a fixed IP address that will not change. 3) As an alternative to 2), if dynamic IP address via DHCP or BOOTP is required, select the required service and then configure IP address change notification from the network settings. Return the unit to the main network. The unit will now have a dynamic IP address, but will notify you if the address changes.
Other networking problems	Test the network cable by connecting it to another network device, then Ping that device from your workstation. See the instructions above.
Camera is accessible locally, but not externally	
Broadband router configuration	To configure your broadband router to allow incoming data traffic to the camera: Enable the NAT-traversal feature which will attempt to automatically configure the router to allow access to the camera. This is enabled from Setup > System Options > Network > TCP/IP Advanced .
Firewall protection	Check the Internet firewall with your system administrator.
Default routers required	Check if you need to configure the default router settings.
Problems with the MPEG-4 format	
No MPEG-4 displayed in the client	Check that the correct network interface is selected in the AMC control panel applet (network tab).
	Check that the relevant MPEG-4 connection methods are enabled in the AMC control panel applet (network tab).
	In the AMC control applet, select the MPEG-4 tab and click the button Set to default MPEG-4 decoder.
No multicast MPEG-4 displayed in the client	Check with your network administrator that the multicast addresses used by the camera are valid for your network.
	Check with your network administrator to see if there is a firewall preventing viewing.
Multicast MPEG-4 only accessible by local clients	Check if your router supports multicasting, or if the router settings between the client and the server need to be configured. The TTL (Time To Live) value may need to be increased.

Poor rendering of MPEG-4 images	Color depth set incorrectly on clients. Set to 16-bit or 32-bit color. If text overlays are blurred, or if there are other rendering problems, you may need to enable Advanced Video Rendering from the MPEG-4 tab in the AMC control panel applet. Ensure that your graphics card is using the latest device driver. The latest drivers can usually be downloaded from the manufacturer's web site.
Color saturation is different in MPEG-4 and Motion JPEG	Modify the settings for your graphics adapter. Please see the adapter's documentation for more information.
Lower frame rate than expected	Reduce number of applications running on the client computer. Check with the system administrator that there is enough bandwidth available. See also the online help. Check in the AMC control panel applet (MPEG-4 tab) that video processing is not set to Decode only I frames . Lower the image resolution.
Lost or poor images in pre-trigger buffer (MPEG-4 video stream)	Make sure that Cyclic refresh under Setup > Video Et Image > Advanced > MPEG-4 is disabled.
Image degeneration	Decrease the GOV length, see the online help for more information.
The Power indicator is not constantly lit	
Faulty power supply	Check that you are using an AXIS PS-L power supply.
The Status indicator LED is flashing red and the camera is inaccessible	
A firmware upgrade has been interrupted or the firmware has otherwise been damaged	See the <i>Emergency Recovery Procedure</i> above.
No images displayed on web page	
Problem with AMC (<i>Internet Explorer only</i>)	To enable the updating of video images in Microsoft Internet Explorer, set your browser to allow ActiveX controls. Also, make sure that AXIS Media Control (AMC) component is installed on your workstation.
Installation of additional ActiveX component restricted or prohibited	Configure your camera to use a Java applet for updating the video images under Live View Config > Layout > Default Viewer for Internet Explorer. See the online help for more information.
Video/Image problems, general	
Image too dark or too light	Check the video image settings. See the online help on Video and Image Settings.
Decreased image quality in zoomed in view	The camera requires sufficient light to deliver good image quality in zoomed in view. Better indoor lighting will increase image quality.
Missing images in uploads	This can occur when trying to use a larger image buffer than is actually available. Try lowering the frame rate or the upload period.
Slow image update	Configuring, for example, pre-buffers, motion detection, high-resolution images, high frame rates, etc, will reduce the performance of the camera.
Poor performance	Poor performance may be caused by for example, heavy network traffic, multiple users accessing the unit, low performance clients, use of features such as Motion Detection, Event handling, Image rotation other than 180 degrees.
Poor quality snapshot images	
Screen incorrectly configured on your workstation	In Display Properties, configure your screen to show at least 65000 colors, i.e. at least 16-bit. Using only 16 or 256 colors will produce dithering artifacts in the image.
No Pan Tilt Zoom movement	
Problem with QuickTime	Limited click-in-image functionality in QuickTime, use the pan, tilt, zoom toolbars instead.
Browser freezes	
Netscape 7.x or Firefox 1.4 (or later) can sometimes freeze on a slow computer	Lower the image resolution.
Problems uploading files	
Limited space	There is only limited space available for the upload of your own files. Try deleting existing files to free up space.

Motion Detection triggers unexpectedly	
Changes in luminance	Motion detection is based upon changes in luminance in the image. This means that if there are sudden changes in the lighting, motion detection may be triggered mistakenly. Lower the sensitivity setting to avoid problems with luminance.
No audio	
Incorrect setup	Check the sound card in the PC. Ensure that the mute button is not pressed and the volume settings are correct.
No audio or very poor audio quality	Check that the correct Audio Input source is selected under Setup > Audio > Source . Select Microphone for the internal microphone or for a connected external microphone. Select Line for a connected line in source.
Audio volume too low/high	
Volume settings incorrect	The volume of the microphone is either too high or too low. Change the volume for the microphone in the toolbar on the Live View page.
Poor audio quality	
Too many users	Too many users/clients connected to the camera may affect the sound quality adversely. Try limiting the number of clients allowed to connect under Basic Configuration > Users .
CPU overloaded	Reduce the number of listeners and viewers and decrease the image resolution and compression.
Unsynchronized audio and video	It is recommended that the camera's time setting is synchronized with an NTP Server. This is enabled under System Options > Date & Time .
Distorted audio	Check that the correct Audio Input source is selected under Setup > Audio > Source . Select Microphone for the internal microphone or for a connected external microphone. Select Line for a connected line in source.
Stuttering audio	Audio break-up (stuttering audio) can be reduced using the Audio Buffer in AXIS Media Control. Right-click the video image and select 'Settings' and 'Audio'. A higher audio buffering level will reduce audio break-up, but may introduce a noticeable lag in audio transmission.

For additional assistance, please contact your reseller or see the support pages on Axis Website at www.axis.com/techsup

Technical Specifications

Item	Specification
Models	AXIS 212 PTZ Network Camera AXIS 212 PTZ-V Network Camera
Image sensor	3.1 Megapixel 1/2" Micron progressive scan CMOS
Lens	<ul style="list-style-type: none"> • Fujinon, F1.8, fixed iris • Focal length: 2.7mm • Focus range: 0.2m - infinity (from front of lens)
Angle of view	<ul style="list-style-type: none"> • Horizontal: 44°-140° • Vertical: 35°-105°
Zoom	3x, 0.1s from wide to tele
Minimum illumination	<ul style="list-style-type: none"> • 10 Lux Wide mode • 20 Lux Tele mode
Pan range	± 70° instant pan
Tilt range	± 52° instant tilt
Video compression	<ul style="list-style-type: none"> • Motion JPEG • MPEG-4 Part 2 (ISO/IEC 14496-2) with motion estimation • Profiles: Advanced Simple Profile and Simple Profile
Resolutions	<ul style="list-style-type: none"> • 9 resolutions from 640x480 to 160x120 via API • 6 selections via configuration Web page
Frame rate	Up to 30 frames per second in VGA (Motion JPEG and MPEG-4)
Video streaming	<ul style="list-style-type: none"> • Simultaneous Motion JPEG and MPEG-4 • Controllable frame rate and bandwidth • Constant and variable bit rate (MPEG-4)
Image settings	<ul style="list-style-type: none"> • Compression levels: 100 • Configurable color level, brightness, sharpness, white balance, exposure control • Fine tuning of behavior at low light • Overlay capabilities: time, date, text
Shutter time	1/5s to 1/10000s
Audio	<ul style="list-style-type: none"> • Half-duplex or simplex • Built-in microphone and external microphone/line input • Mono audio output (line level) connects to PA system or active speaker with built-in amplifier • Audio compression: AAC LC 8-32 kbit/s, G.711 PCM 64 kbit/s, G.726,ADPCM 32 or 24 kbit/s
Security	<ul style="list-style-type: none"> • Multiple user access levels with password protection • IP address filtering • HTTPS encryption • IEEE 802.1X authentication • Digest authentication
Users	<ul style="list-style-type: none"> • 20 simultaneous users • Unlimited number of users using multicast (MPEG-4)
Alarm and event management	<ul style="list-style-type: none"> • Events triggered by built-in multi-window motion detection, audio detection, external inputs or according to a schedule • Image upload over FTP, email and HTTP • Notification over TCP, email, HTTP and external output • Pre- and post alarm buffer of 9 MB (approx 5 min of 320x240 resolution video at 4 fps)
Connectors	<ul style="list-style-type: none"> • Ethernet 10BaseT/100BaseTX, RJ-45 • Mini DC power jack • Terminal block for 1 alarm input and 1 output • 3.5 mm jack for Mic in (max 80 mVpp) or Line mono input (max 6.4 Vpp), Input impedance: 7.4k Ω • 3.5 mm jack for Line mono output (max 1.3 Vpp) to active speaker, Output impedance: Min 90 Ω

AXIS 212 PTZ/-V – Technical Specifications

Item	Specification
Casing	<ul style="list-style-type: none"> • AXIS 212 PTZ: Polycarbonate base and polycarbonate transparent cover • AXIS 212 PTZ-V: 1000 kg (2200 lbs) impact-resistant casing with metal base and rugged polycarbonate transparent cover • Tamper-proof mounting on wall, hard or drop ceiling
Processors and memory	<ul style="list-style-type: none"> • CPU, video processing and compression: ARTPEC-A • RAM: 32 MB • Flash memory: 8 MB • Battery backed-up real-time clock
Power	<ul style="list-style-type: none"> • 4.9-5.1 V DC max 3.6 W • Power over Ethernet (IEEE 802.3af) Class 1 (max 3.84 W)
Operating conditions	<ul style="list-style-type: none"> • Temperature: +5 to +40° C (41 – 104 °F) • Humidity: 20-80% RH (non-condensing)
Installation, management and maintenance	<ul style="list-style-type: none"> • AXIS Camera Management tool on CD and Web-based configuration • Configuration of backup and restore • Firmware upgrades over HTTP or FTP, firmware available at www.axis.com
Video access from web browser	<ul style="list-style-type: none"> • Camera live view • Video recording to file (ASF) • Sequence tour for up to 20 PTZ presets or external Axis video sources • Customizable HTML pages
Minimum requirements	<ul style="list-style-type: none"> • Pentium III CPU 500 MHz or higher, or equivalent AMD • 128 MB RAM • AGP graphics card, 32 MB RAM • Direct Draw • Windows XP, 2000 • DirectX 9.0 or later • Internet Explorer 6.x or later <p>For other operating systems and browsers see www.axis.com/techsup</p>
System integration support	<ul style="list-style-type: none"> • Open API for application integration including AXIS VAPIX API*, AXIS Media Control SDK* • Event trigger data in video stream • Quality of Service (QoS) Layer 3, DiffServ Model • Embedded Linux operating system <p>* Available at www.axis.com</p>
Supported protocols	<p>IPv4/v6, TCP, ICMP, ARP, RTSP, RTP, RTCP, UDP, IGMP, DHCP, DNS, DynDNS, SOCKS, NTP, UPnP, Bonjour, HTTP, HTTPS, SSL/TLS*,SNMPv1/v2c/v3 (MIB-II), SMTP, FTP. More information on protocol usage available at http://www.axis.com</p> <p>* This product includes software developed by the Open SSL Project for use in the Open SSL Tool kit (www.openssl.org)</p>
Included accessories	<ul style="list-style-type: none"> • Installation Guide • CD with installation and management tools, demo software and User's Manual • Mounting and connector kits • Angled wall mount • Power supply PS-H 5.1 V DC • licenses for 1 encoder and 1decoder, • decoder software for Windows
Accessories Not Included	<p>AXIS 295 Video Surveillance Joystick Multi-user decoder license pack</p>
Video management software (not included)	<p>AXIS Camera Station - Surveillance application for viewing, recording and archiving up to 25 cameras</p> <p>See www.axis.com/partner/adp_partners.htm for further software applications via partners</p>

AXIS 212 PTZ/-V - Technical Specifications

Item	Specification
Approvals	<ul style="list-style-type: none"> • EN55024, EN61000-3-2 • EN61000-3-3 • FCC Part 15 Subpart B Class B • VCCI Class B • ICES-003 Class B • C-tick AS/NZS CISPR 22 • EN60950 • Power supply: UL, CSA
Dimensions	<p>78 x 144 x 132 mm (3.0" x 5.6" x 5.2")</p> <p>AXIS 212 PTZ: 504 g (1.1 lbs)</p> <p>AXIS 212 PTZ-V: 660 g (1.5 lbs)</p>

General performance considerations

When setting up your system, it is important to consider how various settings and situations will affect performance. Some factors affect the amount of bandwidth (the bit rate) required, others can affect the frame rate, and some will affect both. If the load on the CPU reaches its maximum, this will also affect the frame rate.

The following factors are among the most important to consider:

- High image resolutions and/or lower compression levels result in larger images. Bandwidth affected.
- Access by large numbers of Motion JPEG and/or unicast MPEG-4 clients. Bandwidth affected.
- Simultaneous viewing of different streams (resolution, compression) by different clients. Frame rate and bandwidth affected.
- Accessing both Motion JPEG and MPEG-4 video streams simultaneously. Frame rate and bandwidth affected.
- Heavy usage of event settings affects the camera's CPU load. Frame rate affected.
- Enabled motion detection. Frame rate and bandwidth affected.
- Heavy network utilization due to poor infrastructure. Bandwidth affected
- Viewing on poorly performing client PC's lowers perceived performance. Frame rate affected.

Optimizing your system

To see the bandwidth and frame rate currently required by the video stream, AXIS 212 PTZ/-V provides a tool that can be used to display these values directly in the video image.

To do this, special format strings are added as part of a text overlay. Simply add **#r** (average frame rate in fps) and/or **#b** (average bandwidth in kbps) to the overlay.

For detailed instructions, please see the online help for [Video & Image > Text Overlay Settings](#), and the help for [File Naming & Date/Time Formats](#).

Important!

The figures displayed here are the values as delivered by the camera. If other restrictions are currently in force, (for example, bandwidth limitation) these values might not correspond to those actually received by the client. For Motion JPEG, these values will be accurate as long as no frame rate limit has been specified.

Bandwidth

As there are many factors that affect bandwidth, it is very difficult to predict the required amounts. The settings that affect bandwidth are:

- image resolution
- image compression
- frame rate
- MPEG-4 GOV settings
- bit rate control settings
- audio settings

There are also factors in the monitored scene that will affect the bandwidth. These are:

- amount of motion
- image complexity
- lighting conditions

For MPEG-4, if there is only limited bandwidth available, and if this is more important than the image quality, using a constant bit rate (CBR) is recommended. Use a variable bit rate (VBR) if the image quality needs to be maintained at a higher level. If supported on the network, consider also using MPEG-4 multicasting, as the bandwidth consumption will be much lower.

Glossary of Terms

ActiveX – A standard that enables software components to interact with one another in a networked environment, regardless of the language(s) used to create them. Web browsers may come into contact with ActiveX controls, ActiveX documents, and ActiveX scripts. ActiveX controls are often downloaded and installed automatically as required.

AF (Autofocus) – A system by which the camera lens automatically focuses on a selected part of the subject.

Angle – The field of view, relative to a standard lens in a 35mm still camera, expressed in degrees, for example, 30°. For practical purposes, this is the area that a lens can cover, where the angle of view is determined by the focal length of the lens. A wide-angle lens has a short focal length and covers a wider angle of view than standard or telephoto lenses, which have longer focal lengths.

ARP (Address Resolution Protocol) – This protocol is used to associate an IP address to a hardware MAC address. A request is broadcast on the local network to discover the MAC address for an IP address.

ARTPEC (Axis Real Time Picture Encoder) – This chip is used for image compression.

ASIC (Application Specific Integrated Circuit) – A circuit designed for a specific application, as opposed to a general purpose circuit, such as a microprocessor.

Aspect ratio – A ratio of width to height in images. A common aspect ratio used for television screens and computer monitors is 4:3. High-definition television (HDTV) uses an aspect ratio of 16:9.

Autoiris (or DC-Iris) – This special type of iris is electrically controlled by the camera, to automatically regulate the amount of light allowed to enter.

AVI (Audio Video Interleave) – A video format that supports simultaneous playback of audio and video.

Bitmap – A bitmap is a data file representing a rectangular grid of pixels. It defines a display space and color for each pixel (or "bit") in the display space. This type of image is known as a "raster graphic." GIF and JPEG are examples of image file types that contain bitmaps.

Because a bitmap uses this fixed raster method, it cannot easily be rescaled without losing definition. Conversely, a vector graphic image uses geometrical shapes to represent the image, and can thus be quickly rescaled.

Bit rate – The bit rate (in kbit/s or Mbit/s) is often referred to as speed, but actually defines the number of bits/time unit and not distance/time unit.

Bluetooth – Bluetooth is an open standard for wireless transmission of voice and data between mobile devices (PCs, handheld computers, telephones and printers).

Bonjour – Also known as zero-configuration networking, Bonjour enables devices to automatically discover each other on a network, without having to enter IP addresses or configure DNS servers. Bonjour is a trademark of Apple Computer, Inc.

Broadband – In network engineering terms, this describes transmission methods where two or more signals share the same carrier. In more popular terminology, broadband is taken to mean high-speed data

transmission.

CCD (Charged Coupled Device) – This light-sensitive image device used in many digital cameras is a large integrated circuit that contains hundreds of thousands of photo-sites (pixels) that convert light energy into electronic signals. Its size is measured diagonally and can be 1/4", 1/3", 1/2" or 2/3".

CGI (Common Gateway Interface) – A specification for communication between a web server and other (CGI) programs. For example, a HTML page that contains a form might use a CGI program to process the form data once it is submitted.

CF (Common Intermediate Format) – CIF refers to the analog video resolutions 352x288 pixels (PAL) and 352x240 pixels (NTSC). See also *Resolution*.

Client/Server – Client/server describes the relationship between two computer programs in which one program, the client, makes a service request from another program, the server, which fulfils the request. Typically, multiple client programs share the services of a common server program. A web browser is a client program that requests services (the sending of web pages or files) from a web server.

CMOS (Complementary Metal Oxide Semiconductor) – CMOS is a widely used type of semiconductor that uses both negative and positive circuits. Since only one of the circuit types is on at any given time, CMOS chips require less power than chips using just one type of transistor. CMOS image sensors also allow processing circuits to be included on the same chip, an advantage not possible with CCD sensors, which are also much more expensive to produce.

Codec – In communications engineering, a codec is usually a coder/decoder. Codecs are used in integrated circuits or chips that convert for example, analog video and audio signals into a digital format for transmission. The codec also converts received digital signals back into analog format. A codec uses analog-to-digital conversion and digital-to-analog conversion in the same chip.

Codec can also mean compression/decompression, in which case it is generally taken to mean an algorithm or computer program for reducing the size of large files and programs.

Compression – See *Image Compression*.

Contrast – Defines the degree of difference between the lightest and darkest parts of an image or video stream.

DC-Iris – This special type of iris is electrically controlled by the camera, to automatically regulate the amount of light allowed to enter.

DHCP (Dynamic Host Configuration Protocol) – DHCP is a protocol that lets network administrators automate and centrally manage the assignment of Internet Protocol (IP) addresses to network devices in a network.

DHCP uses the concept of a "lease" or amount of time that a given IP address will be valid for a computer. The lease time can vary, depending on how long a user is likely to require the network connection at a particular location.

DHCP also supports static addresses for example, computers running web servers, which need a permanent IP address.

DNS (Domain Name System) – DNS is used to locate and translate Internet domain names into IP (Internet Protocol) addresses. A domain name is a meaningful and easy-to-remember name for an Internet address. For example the domain name www.example.com is much

easier to remember than 192.0.34.166. The translation tables for domain names are contained in Domain name servers.

Domain Server – Domains can also be used by organizations who wish to centralize the management of their (Windows) computers. Each user within a domain has an account that usually allows them to log in to and use any computer in the domain, although restrictions may also apply. The domain server is the server that authenticates the users on the network.

Duplex – See *Full-duplex*.

Ethernet – Ethernet is the most widely installed local area network technology. An Ethernet LAN typically uses special grades of twisted pair wires. The most commonly installed Ethernet systems are 10BASE-T and 100BASE-T10, which provide transmission speeds up to 10 Mbps and 100 Mbps respectively.

ETRAX (Ethernet Token Ring AXIS) – Axis' own microprocessor.

Factory default settings – These are the settings that originally applied for a device when it was first delivered from the factory. If it should become necessary to reset a device to its factory default settings, this will, for many devices, completely reset any settings that were changed by the user.

Firewall – A firewall works as a barrier between networks, for example, between a Local Area Network and the Internet. The firewall ensures that only authorized users are allowed to access the one network from the other. A firewall can be software running on a computer, or it can be a standalone hardware device.

Focal length – Measured in millimeters, the focal length of a camera lens determines the width of the horizontal field of view, which in turn is measured in degrees.

FTP (File Transfer Protocol) – An application protocol that uses the TCP/IP protocols. It is used to exchange files between computers/devices on networks.

Frame – A frame is a complete video image. In the 2:1 interlaced scanning format of the RS-170 and CCIR formats, a frame is made up of two separate fields of 262.5 or 312.5 lines interlaced at 60 or 50 Hz to form a complete frame, which appears at 30 or 25 Hz. In video cameras with a progressive scan, each frame is scanned line-by-line and not interlaced; most are also displayed at 30 and 25 Hz.

Frame rate – The frame rate used to describe the frequency at which a video stream is updated is measured in frames per second (fps). A higher frame rate is advantageous when there is movement in the video stream, as it maintains image quality throughout.

Full-duplex – Transmission of data in two directions simultaneously. In an audio system this would describe for example, a telephone systems. Half-duplex also provides bi-directional communication, but only in one direction at a time, as in a walkie-talkie system. See also *Simplex*.

Gain – Gain is the amplification factor and the extent to which an analog amplifier boosts the strength of a signal. Amplification factors are usually expressed in terms of power. Decibel (dB) is the most common way of quantifying the gain of an amplifier.

Gateway – A gateway is a point in a network that acts as an entry point to another network. In a corporate network for example, a computer server acting as a gateway often also acts as a proxy server and a firewall server. A gateway is often associated with both a router,

which knows where to direct a given packet of data that arrives at the gateway, and a switch, which furnishes the actual path in and out of the gateway for a given packet.

GIF (Graphics Interchange Format) – GIF is one of the most common file formats used for images in web pages. There are two versions of the format, 87a and 89a. Version 89a supports animations, i.e. a short sequence of images within a single GIF file. GIF89a can also be specified for interlaced presentation.

GOV (Group Of VOPs) – A group of VOPs is the basic unit of an MPEG-4 video stream. The GOV contains different types and numbers of VOPs (I-VOPs, P-VOPs, etc.) as determined by the GOV length and GOV structure. See also *VOP*.

GOV length – The GOV length determines the number of images (VOPs) in the GOV structure. See also *GOV* and *VOP*.

GOV structure – The GOV structure describes the composition of an MPEG-4 video stream, as regards the type of images (I-VOPs or P-VOPs) included in the stream, and their internal order. See also *GOV* and *VOP*.

Half-duplex – See *Full-duplex*.

HTML (Hypertext Markup Language) – HTML is the set of "markup" symbols or codes inserted in a file intended for display in web browser. The markup tells the browser how to display the page's words and images for the user.

HTTP (Hypertext Transfer Protocol) – HTTP is the set of rules for exchanging files (text, graphic images, sound, video, and other multimedia files) on the web. The HTTP protocol runs on top of the TCP/IP suite of protocols.

Hub – A (network) hub is used to connect multiple devices to the network. The hub transmits all data to all devices connected to it, whereas a switch will only transmit the data to the device it is specifically intended for.

IEEE 802.11 – A family of standards for wireless LANs. The 802.11 standard supports 1 or 2 Mbit/s transmission on the 2.4 GHz band. IEEE 802.11b specifies an 11 Mbit/s data rate on the 2.4 GHz band, while 802.11a allows up to 54 Mbit/s on the 5 GHz band.

Image compression – Image compression minimizes the file size (in bytes) of an image. Two of the most common compressed image formats are JPEG and GIF.

Interlacing – Interlaced video is video captured at 50 pictures (known as fields) per second, of which every 2 consecutive fields (at half height) are then combined into 1 frame. Interlacing was developed many years ago for the analog TV world and is still used widely today. It provides good results when viewing motion in standard TV pictures, although there is always some degree of distortion in the image.

To view interlaced video on for example, a computer monitor, the video must first be de-interlaced, to produce progressive video, which consists of complete images, one after the other, at 25 frames per second. See also *Progressive scan*.

IP (Internet Protocol) – The Internet Protocol is a method transmitting data over a network. Data to be sent is divided into individual and completely independent "packets." Each computer (or host) on the Internet has at least one address that uniquely identifies it from all others, and each data packet contains both the sender's address and the receiver's address.

The Internet Protocol ensures that the data packets all arrive at the

intended address. As IP is a connectionless protocol, which means that there is no established connection between the communication end-points, packets can be sent via different routes and do not need to arrive at the destination in the correct order.

Once the data packets have arrived at the correct destination, another protocol – Transmission Control Protocol (TCP) – puts them in the right order. See also *TCP*.

IP Address – An IP address is simply an address on an IP network used by a computer/device connected to that network. IP addresses allow all the connected computers/devices to find each other and to pass data back and forth.

To avoid conflicts, each IP address on any given network must be unique. An IP address can be assigned as fixed, so that it does not change, or it can be assigned dynamically (and automatically) by DHCP.

An IP address consists of four groups (or quads) of decimal digits separated by periods, for example, 130.5.5.25. Different parts of the address represent different things. Some part will represent the network number or address, and some other part will represent the local machine address.

See also *IP (Internet Protocol)*.

I-VOP – See *VOP*.

JPEG (Joint Photographic Experts Group) – Together with the GIF file format, JPEG is an image file type commonly used on the web. A JPEG image is a bitmap, and usually has the file suffix '.jpg' or '.jpeg.' When creating a JPEG image, it is possible to configure the level of compression to use. As the lowest compression (i.e. the highest quality) results in the largest file, there is a trade-off between image quality and file size.

kbit/s (kilobits per second) – A measure of the bit rate, i.e. the rate at which bits are passing a given point. See also *Bit rate*.

LAN (Local Area Network) – A LAN is a group of computers and associated devices that typically share common resources within a limited geographical area.

Linux – Linux is an open source operating system within the Unix family. Because of its robustness and availability, Linux has won popularity in the open source community and among commercial application developers.

MAC address (Media Access Control address) – A MAC address is a unique identifier associated with a piece of networking equipment, or more specifically, its interface with the network. For example, the network card in a computer has its own MAC address.

Manual iris – This is the opposite to an auto iris, i.e. the camera iris must be adjusted manually to regulate the amount of light allowed to reach the image sensor.

Mbit/s (Megabits per second) – A measure of the bit rate, i.e. the rate at which bits are passing a given point. Commonly used to give the "speed" of a network. A LAN might run at 10 or 100 Mbit/s. See also *Bit rate*.

Monitor – A monitor is very similar to a standard television set, but lacks the electronics to pick up regular television signals.

Motion JPEG – Motion JPEG is a simple compression/decompression technique for networked video. Latency is low and image quality is guaranteed, regardless of movement or complexity of the image. Image quality is controlled by adjusting the compression level, which in turn

provides control over the file size, and thereby the bit rate.

High-quality individual images from the Motion JPEG stream are easily extracted. See also *JPEG*.

Megapixel – See *Pixel*.

MPEG (Moving Picture Experts Group) – The Moving Picture Experts Group develops standards for digital video and audio compression. It operates under the auspices of the International Organization for Standardization (ISO). The MPEG standards are an evolving series, each designed for a different purpose.

MPEG-2 – MPEG-2 is the designation for a group of audio and video coding standards, and is typically used to encode audio and video for broadcast signals, including digital satellite and Cable TV. MPEG-2, with some modifications, is also the coding format used by standard commercial DVD movies.

MPEG-4 – MPEG-4 is a group of audio and video coding standards and related technology. The primary uses for the MPEG-4 standard are web (streaming media) and CD distribution, conversational (videophone), and broadcast television.

Most of the features included in MPEG-4 are left to individual developers to decide whether to implement them or not. This means that there are probably no complete implementations of the entire MPEG-4 set of standards. To deal with this, the standard includes the concept of "profiles" and "levels", allowing a specific set of capabilities to be defined in a manner appropriate for a subset of applications.

Multicast – Bandwidth-conserving technology that reduces bandwidth usage by simultaneously delivering a single stream of information to multiple network recipients.

Multiplexer – A multiplexer is a high-speed switch that provides full-screen images from up to 16 analog cameras. Multiplexers can playback everything that happened on any one camera with no interference from the other cameras on the system.

Network connectivity – The physical (wired or wireless) and logical (protocol) connection of a computer network or an individual device to a network, such as the Internet or a LAN.

NTSC (National Television System Committee) – NTSC is the television and video standard in the United States. NTSC delivers 525 lines at 60 half-frames/second.

NWay – is a telecommunications protocol used to automatically negotiate the highest available transmission speed between network devices. The NWay protocol is also known as auto-negotiation or auto-sensing.

OEM (Original Equipment Manufacturer) – This is a designation for companies that manufacture equipment which is then marketed and sold to other companies under their own names.

PAL (Phase Alternating Line) – PAL is the dominant television standard in Europe. PAL delivers 625 lines at 50 half-frames/second.

PEM (Privacy Enhanced Mail) – An early standard for securing electronic mail. The PEM-format is often used for representing an HTTPS certificate or certificate request.

Ping – Ping is a basic network program used diagnostically to check the status of a network host or device. Ping can be used to see if a particular network address (IP address or host name) is occupied or not, or if the host at that address is responding normally. Ping can be run from for

example, the Windows Command prompt or the command line in UNIX.

Pixel – A pixel is one of the many tiny dots that make up a digital image. The color and intensity of each pixel represents a tiny area of the complete image.

PoE (Power over Ethernet) – Power over Ethernet provides power to a network device via the same cable as used for the network connection. This is very useful for IP-Surveillance and remote monitoring applications in places where it may be too impractical or expensive to power the device from a power outlet.

PPP (Point-to-Point Protocol) – A protocol that uses a serial interface for communication between two network devices. For example, a PC connected by a phone line to a server.

PPTP (Point-to-Point Tunneling Protocol) – A protocol (set of communication rules) that allows corporations to extend their own corporate network through private “tunnels” over the public Internet. In this way a corporation can effectively use a WAN (Wide Area Network) as a large single LAN (Local Area Network). This kind of interconnection is known as a virtual private network (VPN). See also *VPN*.

Pre/post alarm images – The images from immediately before and after an alarm. These images are stored in a buffer for later retrieval.

Progressive scan – Progressive scan, as opposed to interlaced video, scans the entire picture, line by line every sixteenth of a second. In other words, captured images are not split into separate fields as in interlaced scanning.

Computer monitors do not need interlace to show the picture on the screen, but instead show them progressively, on one line at a time in perfect order, i.e. 1, 2, 3, 4, 5, 6, 7 etc., so there is virtually no “flickering” effect. In a surveillance application, this can be critical when viewing detail within a moving image, such as a person running. A high-quality monitor is required to get the best from progressive scan. See also *Interlacing*.

Protocol – A special set of rules governing how two entities will communicate. Protocols are found at many levels of communication, and there are hardware protocols and software protocols.

Proxy server – In an organization that uses the Internet, a proxy server acts as an intermediary between a workstation user and the Internet. This provides security, administrative control, and a caching service. Any proxy server associated with a gateway server, or part of a gateway server, effectively separates the organization's network from the outside network and the local firewall. It is the firewall server that protects the network against outside intrusion.

A proxy server receives requests for Internet services (such as web page requests) from many users. If the proxy server is also a cache server, it looks in its local cache of previously downloaded web pages. If it finds the page, it is returned to the user without forwarding the request to the Internet. If the page is not in the cache, the proxy server, acting as a client on behalf of the user, uses one of its own IP addresses to request the page from another server over the Internet. When the requested page is returned, the proxy server forwards it to the user that originally requested it.

PTZ – Pan, tilt and zoom.

P-VOP – See *VOP*.

Resolution – Image resolution is a measure of how much detail a digital image can hold: the greater the resolution, the greater the level

of detail. Resolution can be specified as the number of pixel-columns (width) by the number of pixel-rows (height), for example, 320x240.

Alternatively, the total number of pixels (usually in megapixels) in the image can be used. In analog systems it is also common to use other format designations, such as CIF, QCIF, 4CIF, etc.

RTCP (Real-Time Control Protocol) – RTCP provides support for real-time conferencing of groups of any size within an intranet. This support includes source identification and support for gateways like audio and video bridges as well as multicast-to-unicast translators.

RTCP offers quality-of-service feedback from receivers to the multicast group as well as support for the synchronization of different media streams.

RTP (Real-Time Transport Protocol) – RTP is an Internet protocol for the transport of real-time data, for example, audio and video. It can be used for media-on-demand as well as interactive services such as Internet telephony.

RTSP (Real Time Streaming Protocol) – RTSP is a control protocol, and a starting point for negotiating transports such as RTP, multicast and Unicast, and for negotiating codecs.

RTSP can be considered a “remote control” for controlling the media stream delivered by a media server. RTSP servers typically use RTP as the protocol for the actual transport of audio/video data.

Router – A device that determines the next network point to which a packet should be forwarded on its way to its final destination. A router creates and/or maintains a special routing table that stores information on how best to reach certain destinations. A router is sometimes included as part of a network switch. See also *switch*.

Server – In general, a server is a computer program that provides services to other computer programs in the same or other computers. A computer running a server program is also frequently referred to as a server. In practice, the server may contain any number of server and client programs. A web server is the computer program that supplies the requested HTML pages or files to the client (browser).

Sharpness – This is the control of fine detail within a picture. This feature was originally introduced into color TV sets that used notch filter decoders. This filter took away all high frequency detail in the black and white region of the picture. The sharpness control attempted to put some of that detail back in the picture. Sharpness controls are mostly superfluous in today's high-end TVs. The only logical requirement for it nowadays is on a VHS machine.

Simplex – In simplex operation, a network cable or communications channel can only send information in one direction.

SMTP (Simple Mail Transfer Protocol) – SMTP is used for sending and receiving e-mail. However, as it is “simple,” it is limited in its ability to queue messages at the receiving end, and is usually used with one of two other protocols, POP3 or IMAP. These other protocols allow the user to save messages in a server mailbox and download them periodically from the server.

SMTP authentication is an extension of SMTP, whereby the client is required to log into the mail server before or during the sending of email. It can be used to allow legitimate users to send email while denying the service to unauthorized users, such as spammers.

SNMP (Simple Network Management Protocol) – SNMP forms part of the Internet Protocol suite, as defined by the Internet Engineering Task Force. The protocol can support monitoring of network-attached devices for any conditions that warrant administrative attention.

Sockets – Sockets are a method for communication between a client program and a server program over a network. A socket is defined as "the endpoint in a connection." Sockets are created and used with a set of programming requests or "function calls" sometimes called the sockets application programming interface (API).

SSL/TSL (Secure Socket Layer/Transport Layer Security) – These two protocols (SSL is succeeded by TSL) are cryptographic protocols that provide secure communication on a network. SSL is commonly used over HTTP to form HTTPS, as used for example, on the Internet for electronic financial transactions. SSL uses public key certificates to verify the identity of the server.

Subnet/subnet mask – A subnet is an identifiably separate part of an organization's network. Typically, a subnet may represent all the machines at one geographic location, in one building, or on the same local area network (LAN). Having an organization's network divided into subnets allows it to be connected to the Internet with a single shared network address.

The subnet mask is the part of the IP address that tells a network router how to find the subnet that the data packet should be delivered to. Using a subnet mask saves the router having to handle the entire 32-bit IP address; it simply looks at the bits selected by the mask.

Switch – A switch is a network device that connects network segments together, and which selects a path for sending a unit of data to its next destination. In general, a switch is a simpler and faster mechanism than a router, which requires knowledge about the network and how to determine the route. Some switches include the router function. See also *Router*.

TCP (Transmission Control Protocol) – TCP is used along with the Internet Protocol (IP) to transmit data as packets between computers over the network. While IP takes care of the actual packet delivery, TCP keeps track of the individual packets that the communication (for example, requested a web page file) is divided into, and, when all packets have arrived at their destination, it reassembles them to re-form the complete file.

TCP is a connection-oriented protocol, which means that a connection is established between the two end-points and is maintained until the data has been successfully exchanged between the communicating applications.

Telnet – Telnet is a simple method with which to access another network device, for example, a computer. The HTTP protocol and the FTP protocols allow you to request specific files from remote computers, but do not allow you logon as a user of that computer. With Telnet, you log on as a regular user with whatever privileges you may have been granted for specific applications and data residing on that computer.

TVL (TV Lines) – A method of defining resolutions in analog video.

UDP (User Datagram Protocol) – UDP is a communications protocol that offers limited service for exchanging data in a network that uses the Internet Protocol (IP). UDP is an alternative to the Transmission Control Protocol (TCP). The advantage of UDP is that it is not required to deliver all data and may drop network packets when there is for example, network congestion. This is suitable for live video, as there is no point in re-transmitting old information that will not be displayed anyway.

Unicast – Communication between a single sender and a single receiver over a network. A new connection is established for each new user.

URL (Uniform Resource Locator) – An "address" on the network.

USB – (Universal Serial Bus) A plug-and-play interface between a computer and peripheral devices, for example, scanners, printers, etc.

Varifocal lens – A varifocal lens provides a wide range of focal lengths, as opposed to a lens with a fixed focal length, which only provides one.

VPN (Virtual Private Network) – This creates a secure "tunnel" between the points within the VPN. Only devices with the correct "key" will be able to work within the VPN. The VPN network can be within a company LAN (Local Area Network), but different sites can also be connected over the Internet in a secure way. One common use for VPN is for connecting a remote computer to the corporate network, via for example, a direct phone line or via the Internet.

VOP (Video Object Plane) – A VOP is an image frame in an MPEG-4 video stream. There are several types of VOP:

– An I-VOP is complete image frame.

– A P-VOP codes the differences between images, as long as it is more efficient to do so. Otherwise it codes the whole image, which may also be a completely new image.

WAN (Wide-Area-Network) – Similar to a LAN, but on a larger geographical scale.

W-LAN (Wireless LAN) – A wireless LAN is a wireless local area network that uses radio waves as its carrier: where the network connections for end-users are wireless. The main network structure usually uses cables.

Web server – A Web server is a program, which allows Web browsers to retrieve files from computers connected to the Internet. The Web server listens for requests from Web browsers and upon receiving a request for a file sends it back to the browser.

The primary function of a Web server is to serve pages to other remote computers; consequently, it needs to be installed on a computer that is permanently connected to the Internet. It also controls access to the server whilst monitoring and logging server access statistics.

WEP (Wireless Equivalent Privacy) – A wireless security protocol, specified in the IEEE 802.11 standard, which is designed to provide a wireless local area network (WLAN) with a level of security and privacy comparable to that usually expected of a wired LAN. Security is at two different levels; 40-bit and 128-bit encryption. The higher the bit number, the more secure the encryption.

WINS (Windows Internet Naming Service) – Part of the Microsoft Windows NT Server, WINS manages the association of workstation names and locations with IP addresses, without the user or administrator having to be involved in each configuration change.

WPA-PSK (Wi-Fi Protected Access – Pre-Shared Key) – This wireless encryption method uses a pre-shared key (PSK) for key management. Keys can usually be entered as manual hex values, as hexadecimal characters, or as a Passphrase. WPA-PSK provides a greater degree of security than WEP.

Zoom lens – A zoom lens can be moved (zoomed) to enlarge the view of an object to show more detail.

Index

A

Accessing the video stream 14
 Action Buttons 10
 Administrators 15
 Alarm 29, 40
 AMC 8
 AMC Viewer Toolbar 10
 ARP/Ping 33
 Audio 11, 19
 Audio input 19
 Audio output 20
 Auxiliary Power 40
 AXIS Media Control 19

B

Backup 38
 Bandwidth 13
 Bit Rate 18
 Bonjour 8, 37
 Buffer Size 28
 Buffers 28

C

CGI links 24
 Configuration 15
 Constant bit rate 13
 Control Button 6, 39
 Control Panel 11

D

Date & Time 33
 Default Viewer 25
 DNS Configuration 34
 DNS Server 34
 Domain Name 34

E

Emergency Recovery 43
 Enable ARP/Ping 33
 Event Servers 27
 Events 27
 External Video 25

F

Factory Default Settings 39
 Frame Rate 17
 FTP Server 27

G

GOV Settings 18
 Guard Tour 26

H

Half duplex 19
 Host Name 34
 HTML Examples 25

HTTP API 24
 HTTP Server 27
 HTTPS 32

I

I/O Ports 37
 I/O Terminal Block 6, 40
 Include Windows 30
 Input 40
 IP Address Filtering 31

L

Live View 10, 15
 Live View Config 21
 Logs & Reports 38

M

Motion Detection 29, 40
 Motion JPEG 13
 MPEG-4 13
 MPEG-4 clients 13
 MPEG-4 protocols 14
 MPEG-4 Settings 18

N

NAT traversal 9, 35
 Network Connector 6
 Network Settings 33
 NTP Server 33

O

Output 40
 Overview image 11
 Own web files 22

P

Port Status 30
 Ports & Devices 37
 Post-trigger Buffer 28
 Power Connector 6
 Preset Positions 26
 Pre-trigger Buffer 28
 PTZ 26
 PTZ Commands 24
 Push to talk 19

Q

QuickTime 8, 13, 23

R

Real Player 8, 13
 Recovery 43
 Referrals 31
 Restore 38

S

Scheduled Event 29
 Security 31

Security/Users 31
 Sequence mode 25, 26
 Server Time 33
 Services 33
 Setup 15
 Simplex 19
 Snapshot button 10
 SNMP 36
 Streaming MPEG-4 12
 Support 38
 System Options 31

T

TCP Server 27
 TCP/IP Settings 33
 Terminal Block 40
 Time Mode 33
 Troubleshooting 42

U

Upgrade Server 38
 UPnP 37
 User Defined Links 24
 User List 31

V

Variable bit rate 13
 Video Stream 16