



PRODUCT INSTRUCTIONS

	Specification Number	Catalog Section
INSTRUCTIONS	6208	1b
MODEL: Indoor Ceiling Housing 21888		

STANDARD INSTALLATION PROCEDURE

- Carefully remove the unit from the box.
- Remove the housing top by removing the (4) #8-32 screws using a Phillips screwdriver.
- Install the camera on the camera bracket using the 1/4-20 bolt provided. The position of the bracket is adjustable depending upon the size and viewing angle.
- Position the housing in the desired location and mark the location of the four mounting holes.
- Pass electrical and video cables through the access hole in the back of the housing or one of the two knockouts in the bottom of the housing.
- Secure the housing in place (hardware not included).
- Adjust the camera angle, and tighten the camera bracket.
- Attach the housing top back to the housing using the (4) #8-32 screws, or security screws.

QTY.	PART NUMBER	DESCRIPTION
A 1	21-TOCE20C	HOUSING TOP
	50-VL1576	ACEM20 HOUSING TOP
B 1	30-VL1310	CE20 MOUNTING PLATE
C 1	WDCEM20	REPLACEMENT WINDOW
D 4	90-BTSR04	8-32X1/2 RD PHILLIPS HD SS
	90-BTSES01	8-32x1/2 SS SECURITY HEAD SCREW
E 2	90-BTHH11	1/4-20 X 1/2 HEX HD ZINC
F 2	92-WSFL01	1/4 SAE FLAT WASHER 18-8 SS
G 2	92-WSSL01	1/4 SPLIT LOCKWASHER 18-8 SS
H 1	30-VL787	CAMERA MOUNT BRKT
I 2	90-BTSR21	6-32 X 1/4" RD PHILLIPS SS
J 1	76-ACHPCB24HT	PCB FOR ACH13, HEATER ONLY
K 1	72-POH1000	25W HEATER

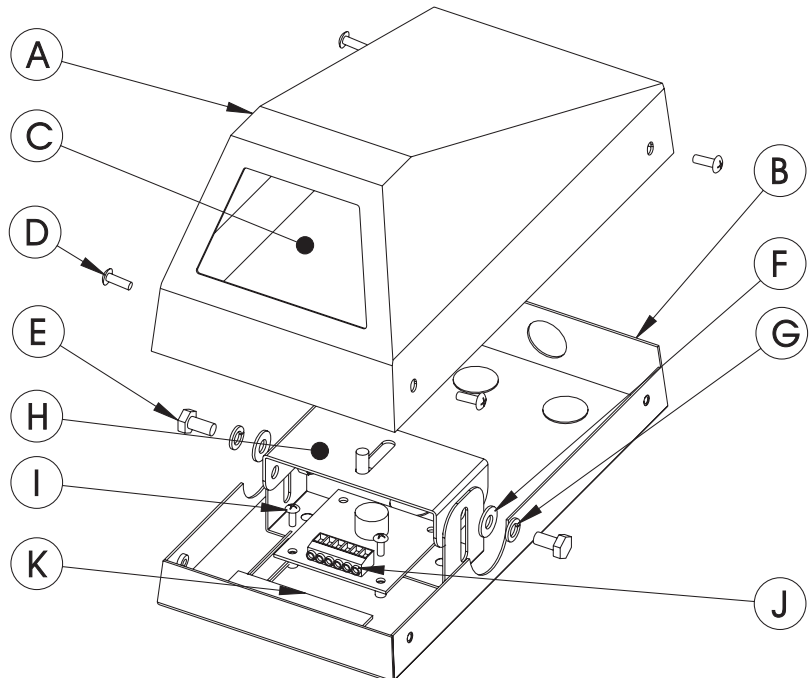
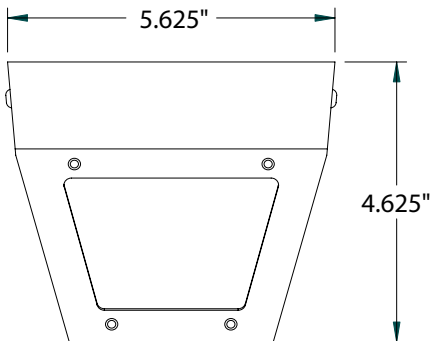
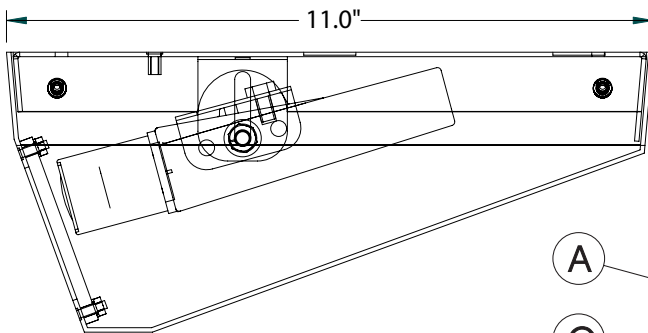

IMPORTANT SAFEGUARDS

1. **Read Instructions** - All the safety and operating instructions should be read before the unit is operated.
2. **Retain Instructions** - The safety and operating instructions should be retained for future reference.
3. **Heed Warnings** - All warnings on the unit and in the operating instructions should be adhered to.
4. **Follow Instructions** - All operating and user instructions should be followed.
5. **Electrical Connections** - Only a qualified electrician should make electrical connections.
6. **Attachments** - Do not use attachments not recommended by the product manufacturer as they may cause hazards.
7. **Cable Runs** - All cable runs must be within permissible distance.
8. **Mounting** - This unit must be properly and securely mounted to a supporting structure capable of sustaining the weight of the unit. Accordingly:
 - a. The installation should be made by a qualified installer.
 - b. The installation should be in compliance with local codes.
 - c. Care should be exercised to select suitable hardware to install the unit, taking into account both the composition of the mounting surface and the weight of the unit. Be sure to periodically examine the unit and the supporting structure to make sure that the integrity of the installation is intact. Failure to comply with the foregoing could result in the unit separating from the support structure and falling, with resultant damages or injury to anyone or anything struck by the falling unit.

WARRANTY INFORMATION

Videolarm, Incorporated warrants that products sold hereunder shall be fit for the ordinary purpose for which said products are intended and shall be free from defects in material and workmanship for a period of two years from date of sale to buyer. Videolarm makes no other warranty of any kind with respect to this product, whether expressed or implied, including, without limitation, the implied warranty of fitness for a particular purpose.

In the event of a breach of the above warranty, Videolarm shall, at its option, repair or replace said product. This is Videolarm's sole obligation under this warranty. In no event shall Videolarm be liable for any incidental or consequential damages, as defined in section 2-715 of the Uniform Commercial Code by a breach of this warranty.

Videolarm shall repair or replace defective products upon shipment of products prepaid to Videolarm, Inc., 2525 Park Central Blvd., Decatur, GA 30035.

Repairs made necessary by reason of accident, misuse or normal wear shall be charged at Videolarm's standard rate. This warranty gives you specific legal rights, and you may also have other rights which vary from state to state.

SAFETY PRECAUTIONS

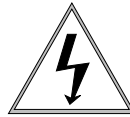
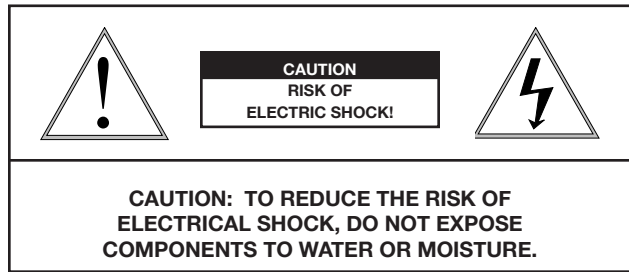

The lightning flash with an arrowhead symbol, within an equilateral triangle, is intended to alert the user to the presence of non-insulated "dangerous voltage" within the product's enclosure that may be of sufficient magnitude to constitute a risk of electric shock to persons.



The exclamation point within an equilateral triangle is intended to alert the user to presence of important operating and maintenance (servicing) instructions in the literature accompanying the appliance.

UNPACKING

Unpack carefully. Electronic components can be damaged if improperly handled or dropped. If an item appears to have been damaged in shipment, replace it properly in its carton and notify the shipper.

Be sure to save:

1. The shipping carton and packaging material. They are the safest material in which to make future shipments of the equipment.
2. These Installation and Operating Instructions.

SERVICE

If the unit ever needs repair service, the customer should contact Videolarm (1-800-554-1124) for authorization to return and shipping instructions.

TECHNICAL SUPPORT

If technical support is needed, Videolarm has set-up a 24 hour technical support line for their customers.

24 HOUR TECHNICAL SUPPORT

1-800-554-1124